

STATE OF ILLINOIS
DEPARTMENT OF TRANSPORTATION

ROUTE NO.	SECTION	COUNTY	TOTAL SHEETS	SHEET NO.
F.A.I. 57	(02-1B)I	ALEXANDER	16	17
FED. ROAD DIST. NO. 7	ILLINOIS	FED. AID PROJECT-		

SHEET NO. 12
13 SHEETS

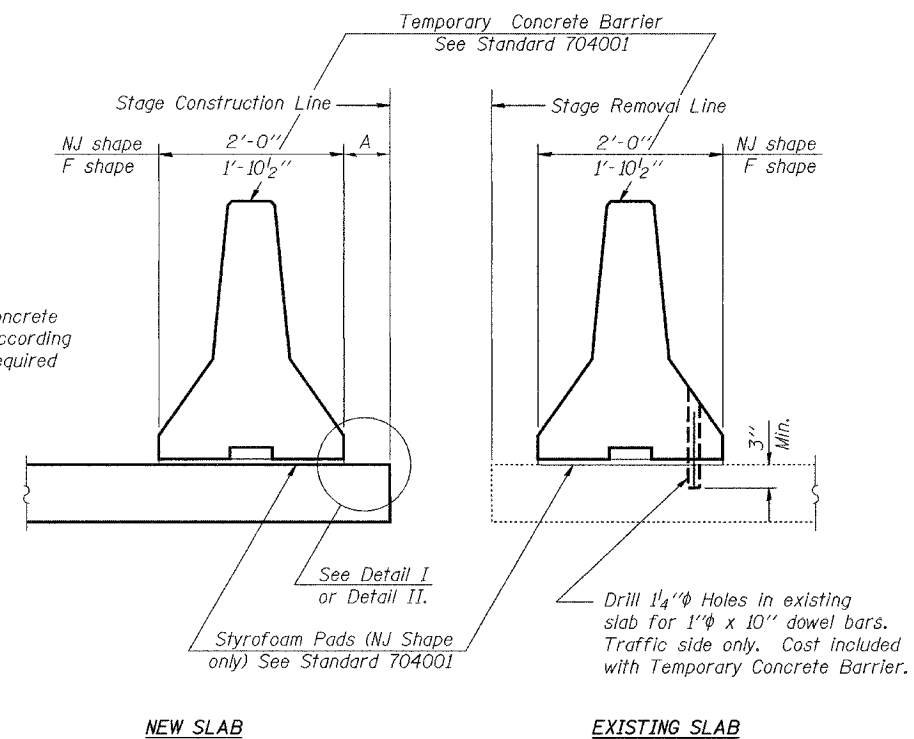

When "A" is 3'-6" or less, the temporary concrete barrier shall be anchored to the new slab according to Detail I or Detail II. No anchorage is required when "A" is greater than 3'-6".

NOTES

Detail I - With Bar Splicer or Couplers:
Connect one (1) 1"x7"x10" steel \bar{P} to the top layer of couplers with 2-5/8" ϕ bolts screwed to coupler at approximate ϕ of each barrier panel.

Detail II - With Extended Reinforcement Bars:
Connect one (1) 1"x7"x10" steel \bar{P} to the concrete slab with 2-5/8" ϕ Expansion Anchors or cast in place inserts spaced between the top layer of reinforcement at approximate ϕ of each barrier panel.

Cost of anchorage is included with Temporary Concrete Barrier.

SECTIONS THRU SLAB

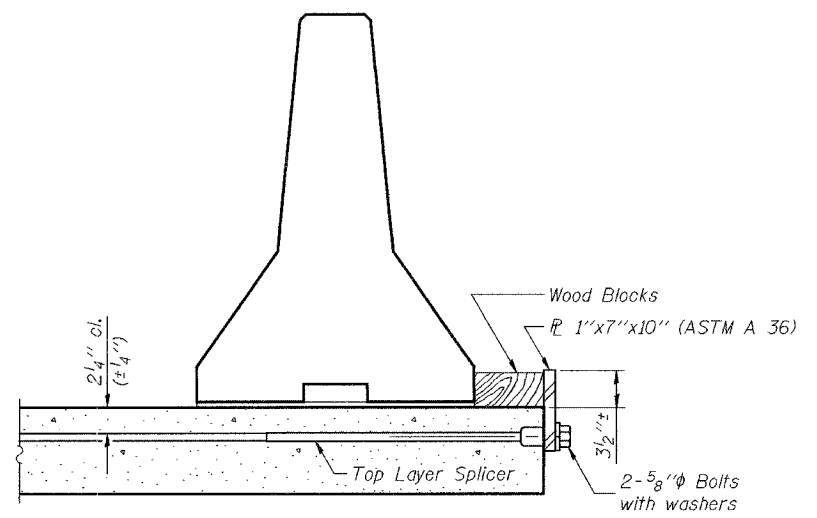

DETAIL I

The 1"x7"x10" Plate shall not be removed until Stage II Construction forms and reinforcement bars are in place.

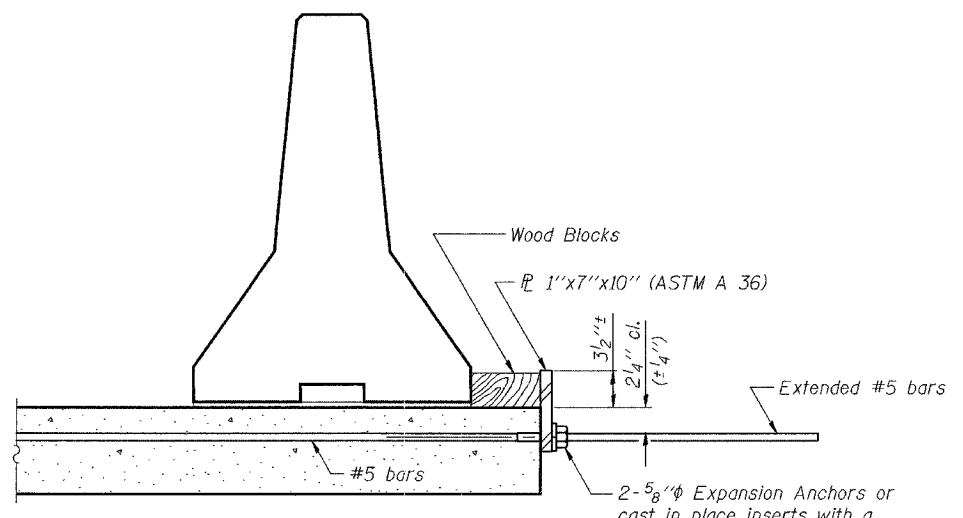

DETAIL II

The 1"x7"x10" Plate shall not be removed until Stage II Construction forms and all reinforcement bars are in place and the concrete is ready to be placed.

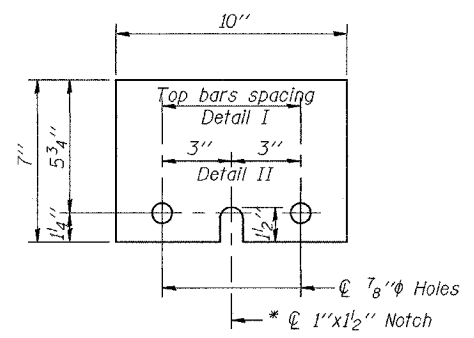

DESIGNED	JSB
CHECKED	ATH
DRAWN	ballva
CHECKED	JSB ATH

MARCH 8, 2004

EXAMINED *John A. Morris*
ENGINEER OF STRUCTURAL SERVICES

PASSED
ENGINEER OF BRIDGES AND STRUCTURES

R-27 9-01-03

TEMPORARY CONCRETE BARRIER
I-57 OVER CACHE RIVER
F.A.I. RTE. 57 - SEC. (02-1B)I
ALEXANDER COUNTY
STATION 943+72.00
SN 002-0003 (NB) & 002-0004 (SB)