

TYPICAL SECTIONS

F. A. I. SITE	SECTION	COUNTY	TOTAL SHEETS	SHEET NO.
24	*	JOHNSON	150	11
STA. TO STA.				
FED. ROAD DIST. NO.		ILLINOIS	FED. AID PROJECT	
* (44-5,6)RS, BSMART FY04-3 98836				

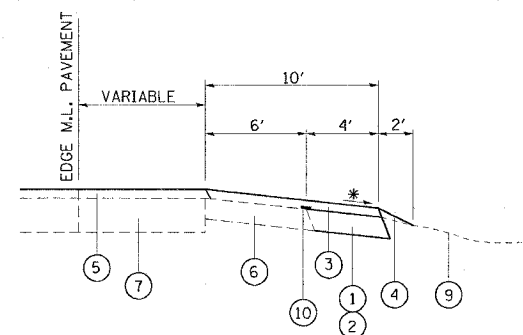

- ① PROP. BITUMINOUS SHOULDERS, SUPERPAVE, 8" (CONSTRUCT IN 2 LIFTS)
- ② PROP. EXCAVATING AND GRADING EXISTING SHOULDER
- ③ PROP. BITUMINOUS SHOULDERS, SUPERPAVE (CONSTRUCT IN 2 LIFTS)
- ④ PROP. AGGREGATE SHOULDERS, TYPE B (WEDGE)
- ⑤ PROP. BITUMINOUS CONCRETE BINDER AND SURFACE COURSE (CONSTRUCT IN ACCORDANCE WITH MAINLINE TYPICAL SECTION)
- ⑥ EXIST. BITUMINOUS SHOULDERS
- ⑦ EXIST. 8" P.C.C. PAVEMENT
- ⑧ EXIST. 4" AGGREGATE SUB-BASE
- ⑨ EXIST. GROUNDLINE
- ⑩ PROP. STRIP REFLECTIVE CRACK CONTROL TREATMENT

TO BE USED:

US 45 (VIENNA/HARRISBURG) INTERCHANGE:

RAMP A: RT. STA. 11+09.54 (TL RAMP) TO RT. STA. 17+00 (TL RAMP)
 RAMP B: RT. STA. 15+00 (TL RAMP) TO LT. STA. 25+25.35 (TL RAMP)
 RAMP C: RT. STA. 11+50 (TL RAMP) TO RT. STA. 17+00 (TL RAMP)
 RAMP D: RT. STA. 16+00 (TL RAMP) TO LT. STA. 25+20 (TL RAMP)

IL 146 (VIENNA/GOLCONDA) INTERCHANGE:

RAMP A: LT. STA. 10+65 (TL RAMP) TO RT. STA. 23+54 (TL RAMP)
 RAMP B: RT. STA. 17+00 (TL RAMP) TO RT. STA. 19+41 (TL RAMP)
 RAMP C: RT. STA. 10+60 (TL RAMP) TO RT. STA. 20+00 (TL RAMP)

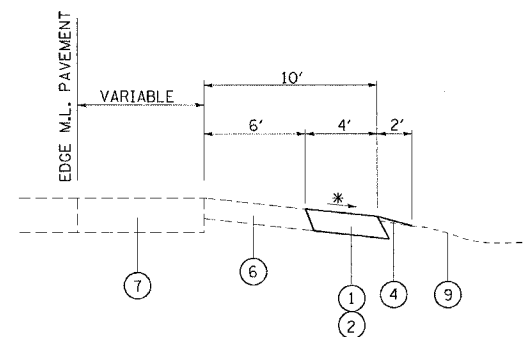

TO BE USED:

US 45 (VIENNA/HARRISBURG) INTERCHANGE:

RAMP A: RT. STA. 1617+98.35 (Q US 45) TO RT. STA. 11+09.54 (TL RAMP)
 RAMP B: RT. STA. 25+25.35 (TL RAMP) TO LT. STA. 1617+89.68 (Q US 45)

IL 146 (VIENNA/GOLCONDA) INTERCHANGE:

RAMP A: LT. STA. 100+98 (Q IL 146) TO RT. STA. 10+65 (TL RAMP)
 RAMP B: RT. STA. 19+41 (TL RAMP) TO RT. STA. 101+18 (Q IL 146)
 RAMP C: RT. STA. 86+05 (Q IL 146) TO RT. STA. 10+60 (TL RAMP)