

F.A.P. RTE.	SECTION	COUNTY	TOTAL SHEETS	SHEET NO.
595	1-3-K	BOCKISLAND	476	239A
STA.		TO STA.		
FED. ROAD DIST. NO.		ILLINOIS FED. AID PROJECT		

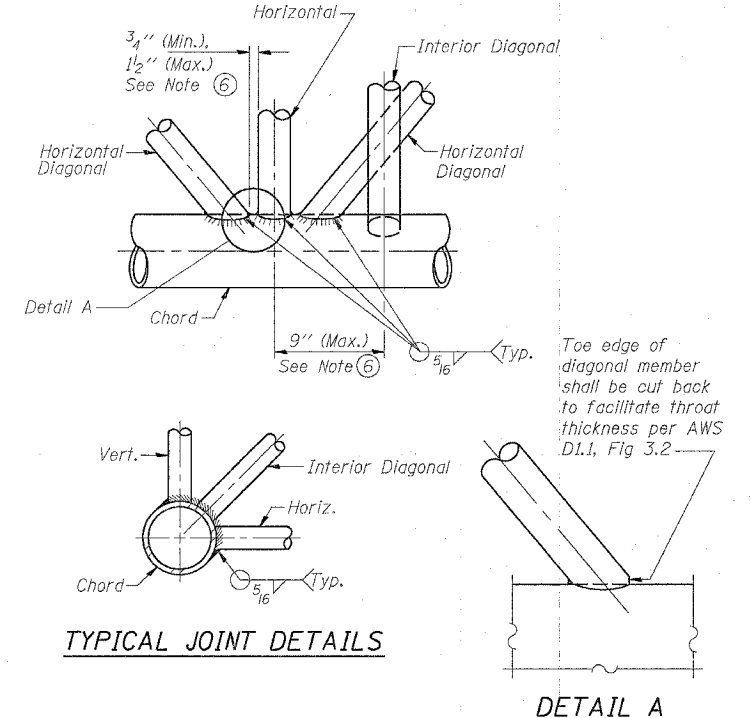

- NOTES**
- Contractor may alternatively use standard aluminum drive-fit cap to close end. 1/2" ϕ drain hole in end plate/drive-fit cap. (Typ. at ends of all chords)
 - 5 1/2" end dimension may vary by +/- 1" to provide uniform panel spacing (P).
 - Panel spacing (P) shall be uniform for entire truss and between 4'-0" and 5'-0" for Type I-A or 4'-0" and 5'-6" for Types II-A and III-A.
 - Vertical Diagonals in front and back face shall alternate.
 - Hidden lines show wind bracing alternates direction between planes of top and bottom chords.
 - All diagonals shall be detailed for minimum offset from the panel point based on the following: Offset shall be such as to provide a 3/4" minimum to 1/2" maximum clearance between any diagonal and any horizontal or vertical member, and to provide clearance for U-bolt connections of signs or walkway brackets.

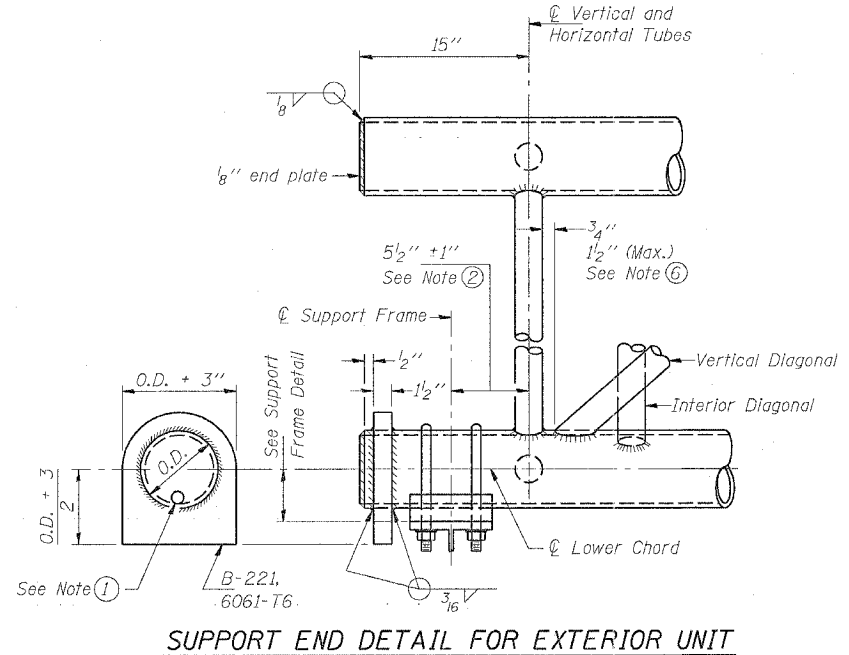
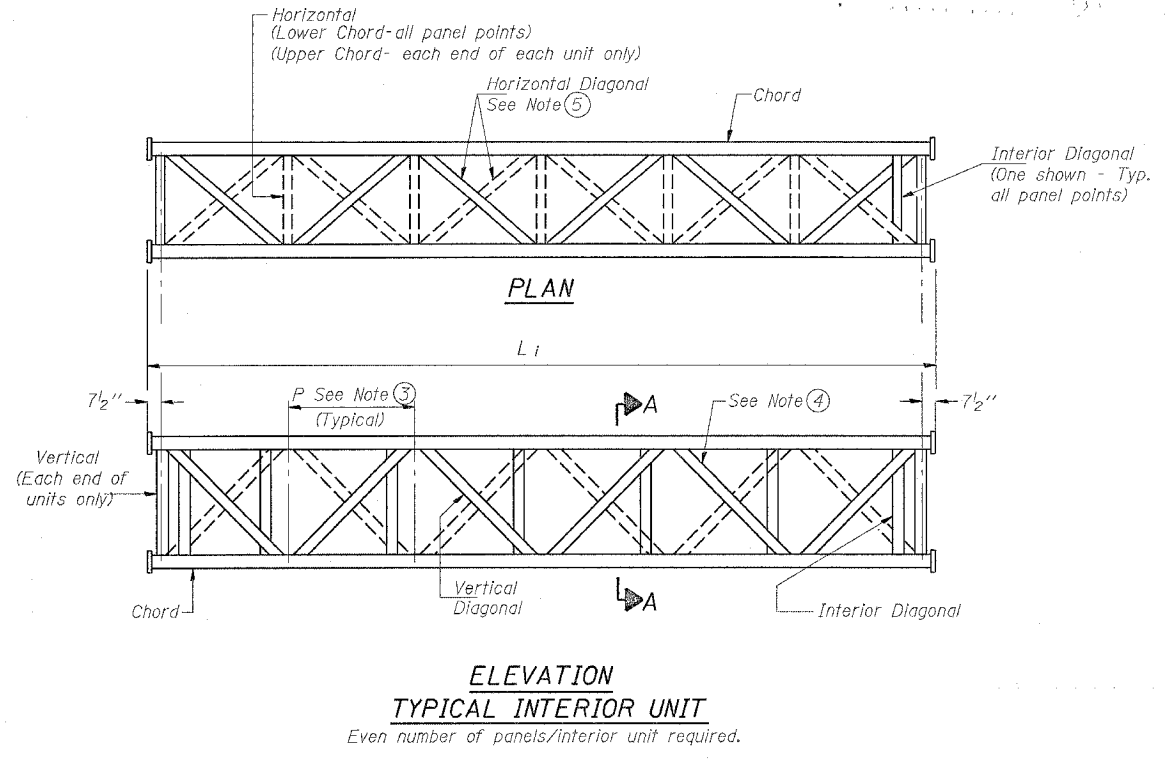
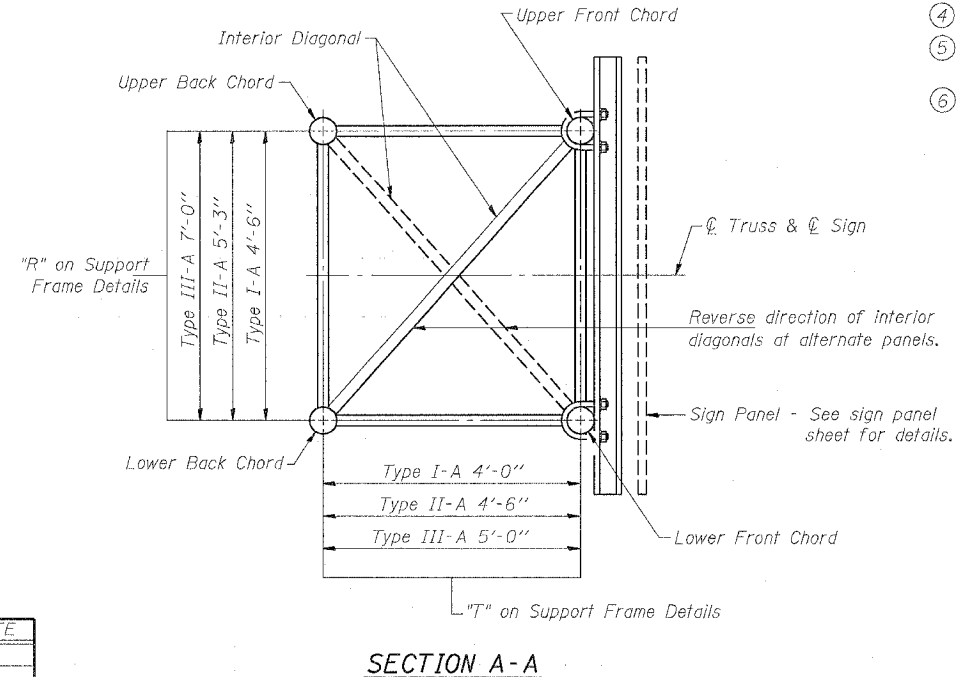
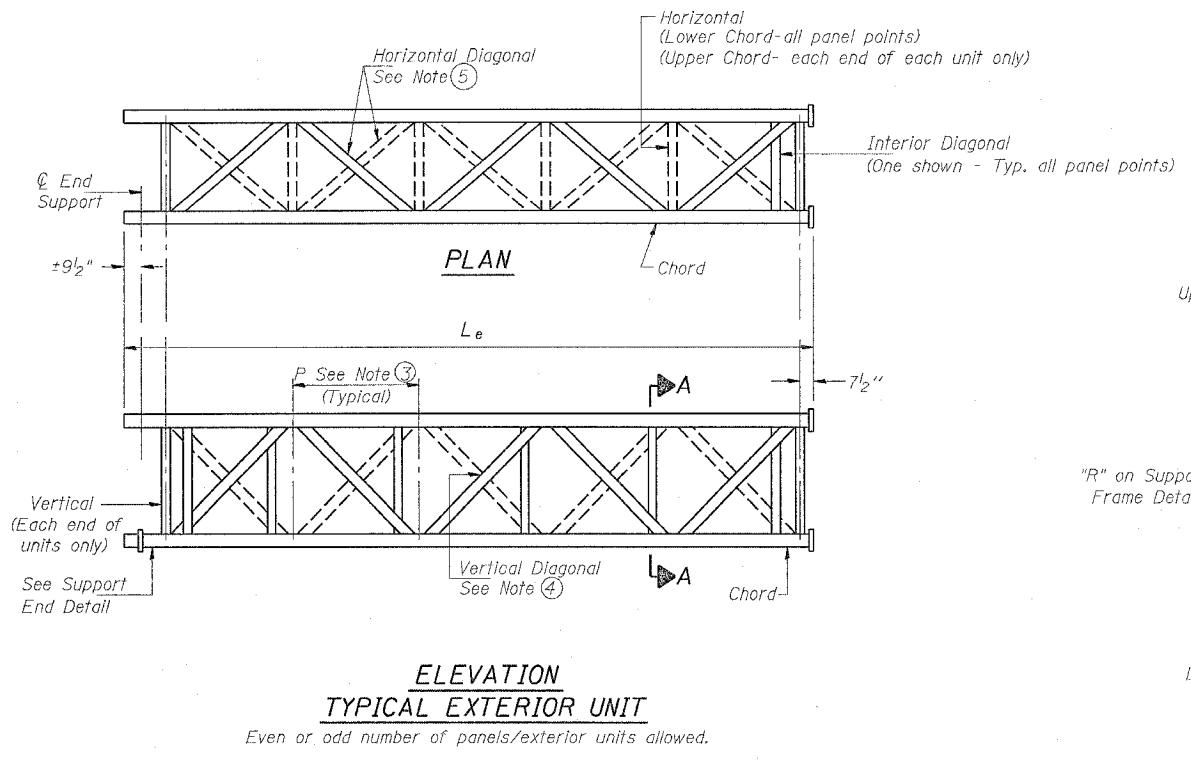

NUMBER	REVISION	DATE

**OVERHEAD SIGN STRUCTURES
 ALUMINUM TRUSS DETAILS
 FOR TRUSS TYPES I-A, II-A and III-A**

REVISIONS		ILLINOIS DEPARTMENT OF TRANSPORTATION
NAME	DATE	

SCALE: VERT. _____
 HORIZ. _____
 DATE _____

DRAWN BY _____
 CHECKED BY _____

PLDT DATE = Wed Dec 22 13:55:12 2004
 FILE NAME = C:\Documents and Settings\johntaylor\My Documents\sign sheets.dgn
 SCALE = 20/2000 / IN.
 REFERENCE = 01019