

BUTT JOINT AND RAMP DETAILS

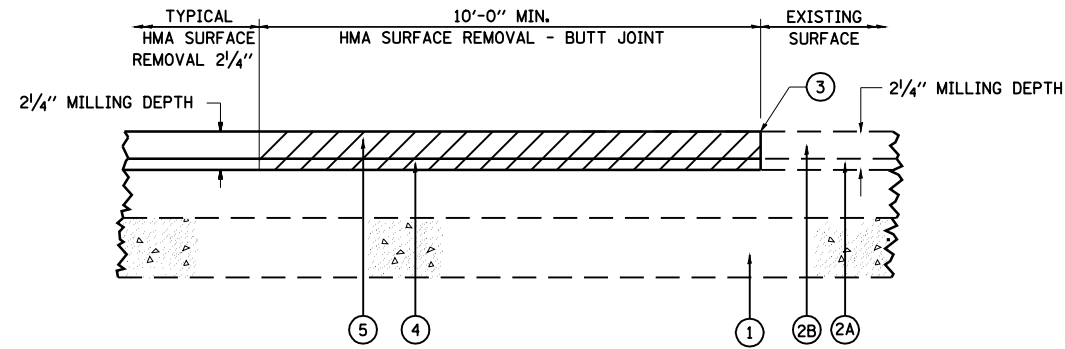

BUTT JOINT "A" DETAIL

MAINLINE

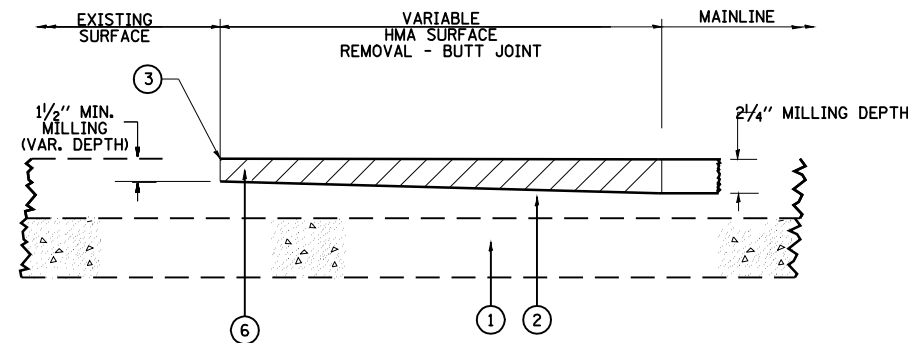

BUTT JOINT "B" DETAIL

SIDEROADS

LEGEND

- DENOTES PROPOSED BITUMINOUS SURFACE REMOVAL
- ① EXISTING P.P.C. PAVEMENT
- ② EXISTING HMA SURFACE COURSE
- ②A EXISTING LEVELING BINDER
- ②B EXISTING HMA RESURFACING
- ③ PROPOSED SAW CUT (INCL. IN THE COST OF HMA SURF. REM.)
- ④ PROPOSED LEVELING BINDER (3/4")
- ⑤ PROPOSED HMA SURFACE COURSE (1 1/2")
- ⑥ PROPOSED INCIDENTAL HMA SURFACING

PARKING SPACE DETAILS

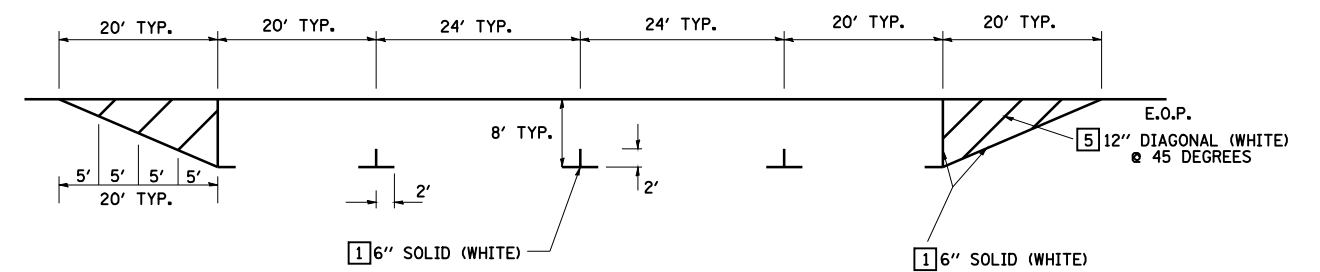

REVISIONS	
NAME	DATE

ILLINOIS DEPARTMENT OF TRANSPORTATION

ROADWAY DETAILS

SCALE: NONE
DATE: 2/2004

DRAWN BY: MLO
CHECKED BY: SJK