

# DETAIL OF SIDEROAD RETURNS

(RURAL SECTION)

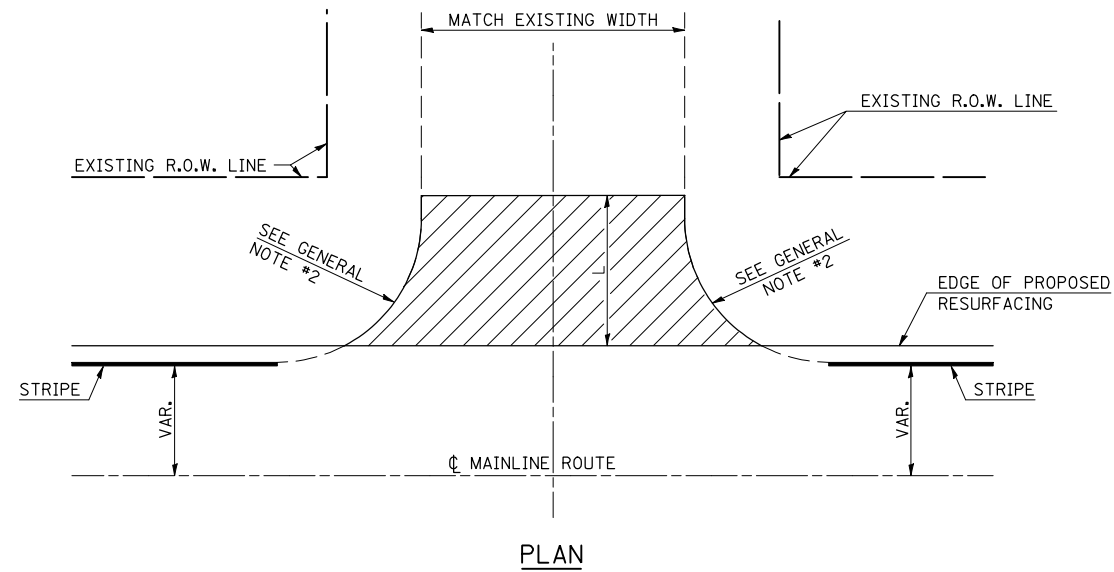

PLAN

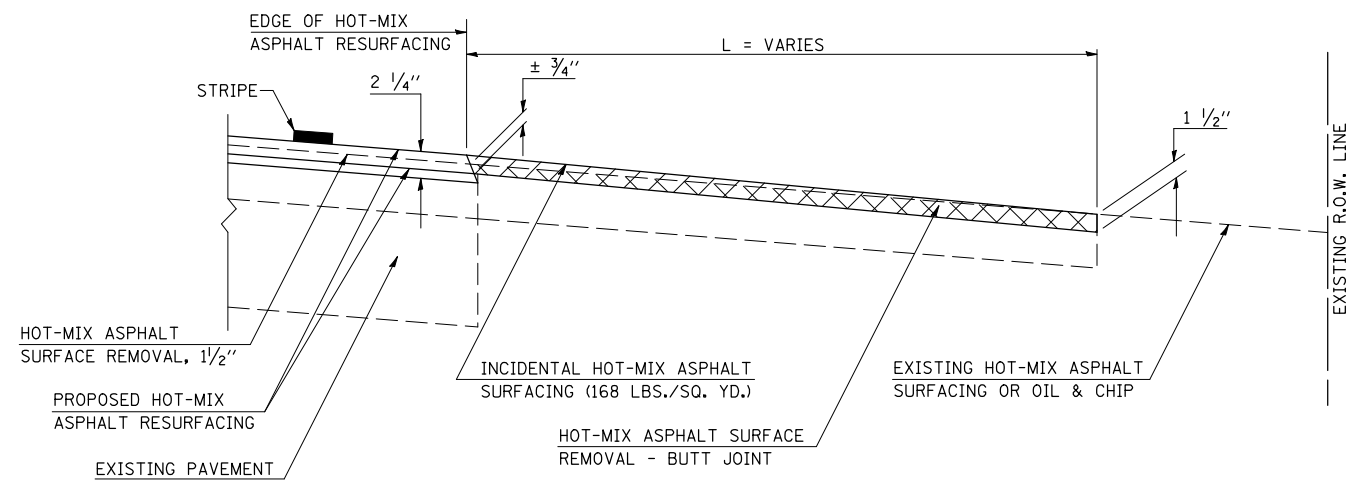

PROFILE

## GENERAL NOTES

1. THE EXISTING SURFACE SHALL BE PREPARED IN ACCORDANCE WITH SECTION 408 OF THE STANDARD SPECIFICATIONS.
2. THE INCIDENTAL HOT-MIX ASPHALT SURFACING IS INTENDED TO RESURFACE THE EXISTING SIDEROADS IN THEIR ENTIRETY. THE EXISTING SIDEROADS SHOULD BE RESURFACED TO MAINTAIN THEIR CURRENT RADII AND SHALL BE RESURFACED TO THE BACK OF RADII.

FILE NAME =	USER NAME = ppersonbr	DESIGNED -	REVISED -
ct:\pw\work\PIWIDOT\PIERSONBR\d0117734\d5	0642-shr-details.dgn	DRAWN -	REVISED -
	PLOT SCALE = 40.0000' / IN.	CHECKED -	REVISED -
	PLOT DATE = 2/6/2009	DATE -	REVISED -

STATE OF ILLINOIS  
DEPARTMENT OF TRANSPORTATION

SIDEROAD RETURNS DETAIL

SCALE: SHEET NO. OF SHEETS STA. TO STA.

F.A.P. RTE.	SECTION	COUNTY	TOTAL SHEETS	SHEET NO.
836	119RS-4 & 119Z RS-2	Champaign	26	21
CONTRACT NO. 70642			ILLINOIS FED. AID PROJECT	