

F.A.P. RTE.	SECTION	COUNTY	TOTAL SHEETS	SHEET NO.
741	*	PIATT	48	43

* 8RS-4&(9,10)RS-3

TO BE INSTALLED IN ALL PAVEMENT TYPES FOR PRESERVING PERMANENT SURVEY MARKERS (PI'S, PT'S, PC'S, POC'S, & POT'S) AND LAND SURVEY MONUMENTS (SECTION OR SUBSECTION CORNERS)

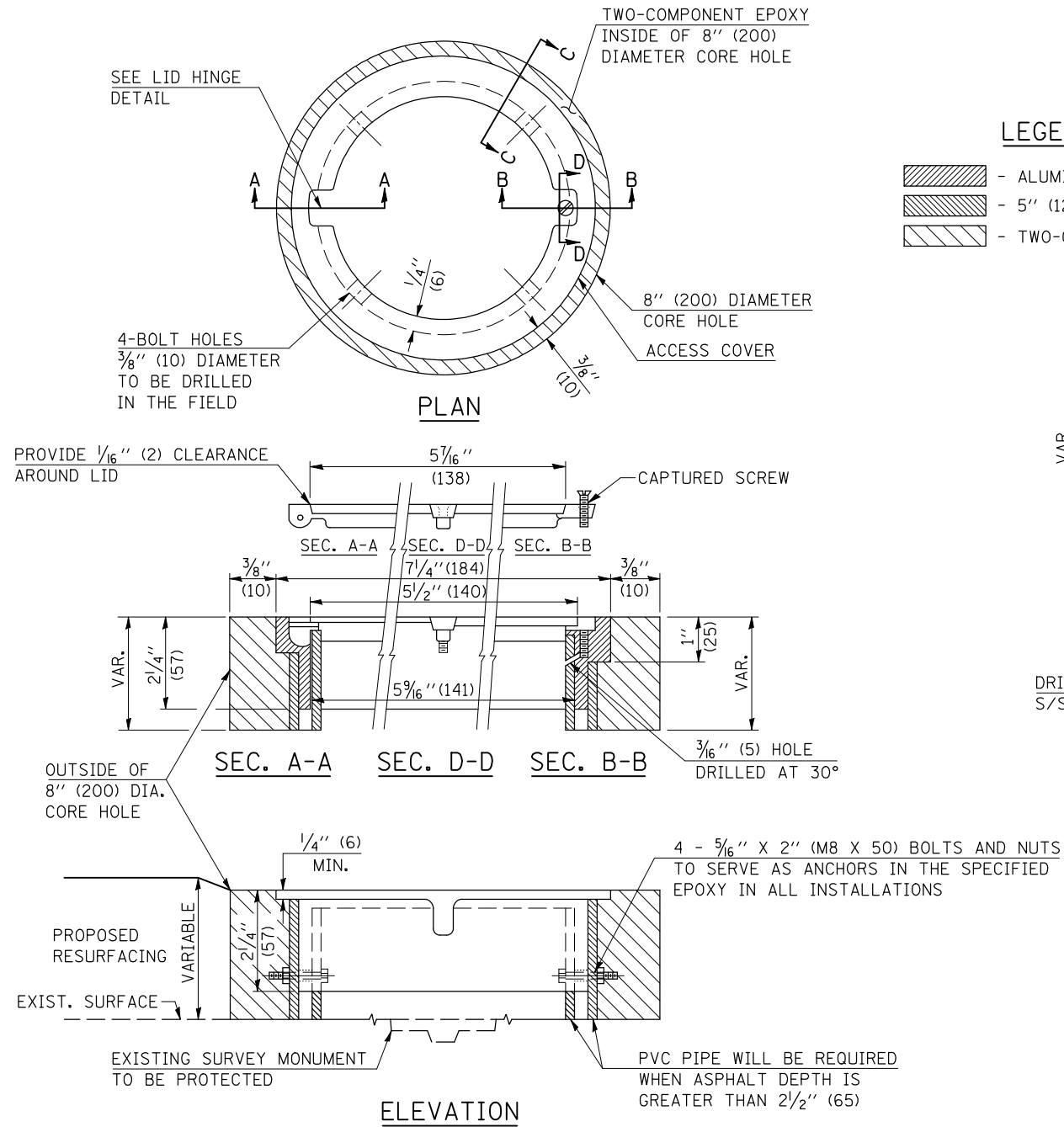

LEGEND

- ALUMINUM CASTING
- 5" (125) OR 6" (150) P.V.C. PIPE
- TWO-COMPONENT EPOXY

SPECIFICATIONS FOR ACCESS COVER FOR USE WITH SURVEY MARKER VAULT(S) AND SURVEY MARKER COVER ASSEMBLY(S): THE ACCESS COVER WILL BE CAST FROM A SPECIAL ALUMINUM ALLOY THAT IS COMPARABLE TO BRONZE IN HARDNESS. THE ACCESS COVER SHALL BE SPECIALLY ENGINEERED AND DESIGNED TO PROVIDE A SNUG FIT, INCORPORATING EQUIDISTANT LOCKING RIDGES, INSIDE A STANDARD 6" (150 mm) DIAMETER, OR OUTSIDE A STANDARD 5" (125 mm) DIAMETER, SCHEDULE 40 PVC PIPE. THE ACCESS COVER SHALL HAVE SPECIAL UNIFORM 1" (25 mm) THICK TOP SURFACE TO PERMIT INFORMATION TO BE EASILY MACHINE-STAMPED INTO IT. THE ACCESS COVER SHALL INCLUDE A STAINLESS CAPTURED SCREW AND AN OPPOSING RECESSED HINGE ASSEMBLY AS ITS LOCKING MECHANISM. THE ACCESS COVER SHALL INCORPORATE A SPECIAL ACCESS HOLE FOR CLEANING AND DRAINAGE, DRILLED AT 30° INSIDE THE RING OF THE ACCESS COVER, TO THE DRILLED AND TAPPED HOLE PROVIDED FOR THE STAINLESS CAPTURED SCREW. COMPOSITION: ALUMINUM 92-93%; MAGNESIUM 6.5-7.5%. STRENGTH: YIELD - 19,000-21,000 PSI (131-145 MPa); TENSILE - 38,000-44,000 PSI (262-303 MPa); ELONGATION - 10-15% IN 2" (50 mm). SPECIFICATIONS: ALLOY 535.0; QQ-A-601Es. NO EXCEPTIONS.

BILL OF MATERIAL

ALUMINUM CASTING OF THE DIMENSIONS AND SPECIFICATIONS SHOWN OR OTHER SUBJECT TO ENGINEER'S APPROVAL OF SHOP DRAWINGS, 4 EACH - 5/16" X 2" (M8 X 50) BOLTS WITH NUTS, EPOXY, 5" OR 6" (125 mm OR 150 mm) DIAMETER P.V.C. PIPE, SCHEDULE 40 (WHEN REQUIRED).

GENERAL NOTES

1. WORK SHALL NOT START ON THIS ITEM UNTIL THE FINAL LIFT OF SURFACE HAS BEEN COMPLETED.
2. THE SURVEY MONUMENT COVER ASSEMBLY SHALL BE CENTERED ABOVE THE SURVEY MONUMENT TO BE PROTECTED.
3. MODIFICATION OF THE ALUMINUM CASTING SHALL BE DONE BY GRINDING OR SAWING WHEN HEIGHT REDUCTION IS REQUIRED.
4. ALL SURVEY MONUMENT COVER ASSEMBLIES SHALL BE PLACED 1/4" (6 mm) ± BELOW THE FINAL SURFACE.
5. ALUMINUM CASTING SHALL BE PLACED OVER A 5" (125 mm) P.V.C. PIPE OR INSIDE OF A 6" (150 mm) P.V.C. PIPE WHEN AN INCREASE IN HEIGHT IS REQUIRED.
6. THE CASTING SHALL BE ANCHORED IN THE 8" (200 mm) DIAMETER CORE HOLE WITH TWO-COMPONENT EPOXY CONFORMING TO APPLICABLE PORTIONS OF ARTICLE 1025.01 OF THE STANDARD SPECIFICATIONS.
7. THIS WORK WILL BE PAID FOR AT THE CONTRACT UNIT PRICE EACH FOR SURVEY MONUMENT COVER ASSEMBLY WHICH PRICE SHALL INCLUDE ALL LABOR AND MATERIAL AS SPECIFIED INCLUDING CORING THE NEW PAVEMENT SURFACE AND EPOXY. NO ADDITIONAL COMPENSATION WILL BE ALLOWED.
8. THE 8" (200 mm) DIAMETER CORE HOLE SHALL BE SUBJECT TO THE APPROVAL OF THE ENGINEER.

Note: All dimensions are in INCHES (millimeters) unless otherwise shown.

DATE	REVISIONS	NAME	ILLINOIS DEPARTMENT OF TRANSPORTATION
11/06	REPLACED DETAIL D-1.04	TJB	SURVEY MONUMENT COVER ASSEMBLY
			DISTRICT 5 DETAIL NO. Z0070100