

F.A.P. RTE.	SECTION	COUNTY	TOTAL SHEETS	SHEET NO.
22	*	FULTON	71	10
STA.		TO STA.		
FED. ROAD DIST. NO.		ILLINOIS FED. AID PROJECT		
* 133RS-3;134RS-2;135RS-5				

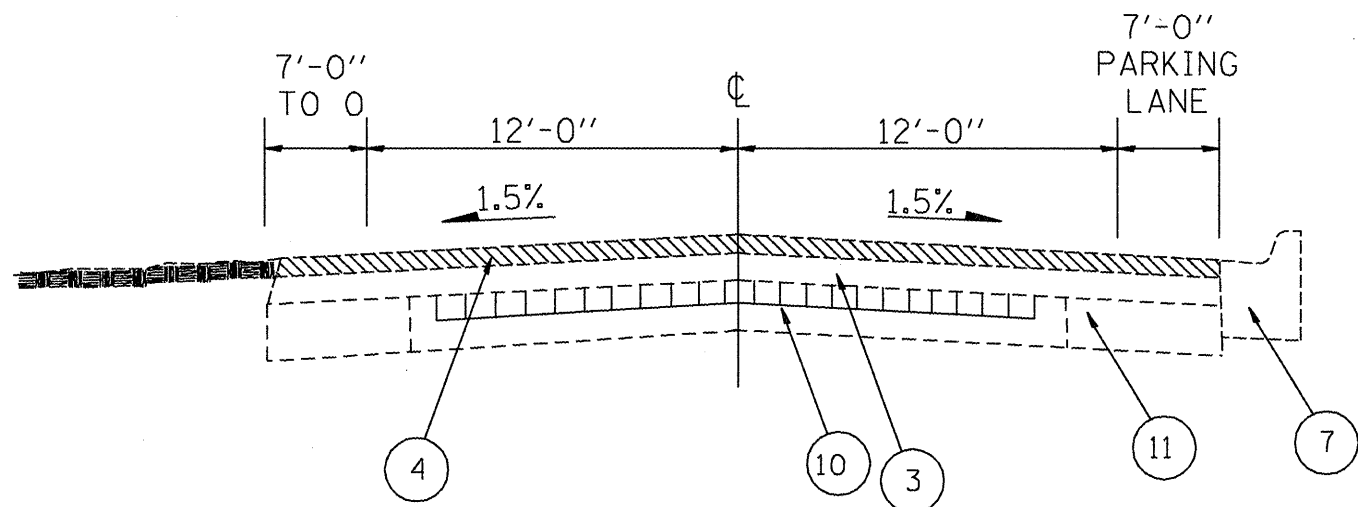

STA 54+94 - 56+60

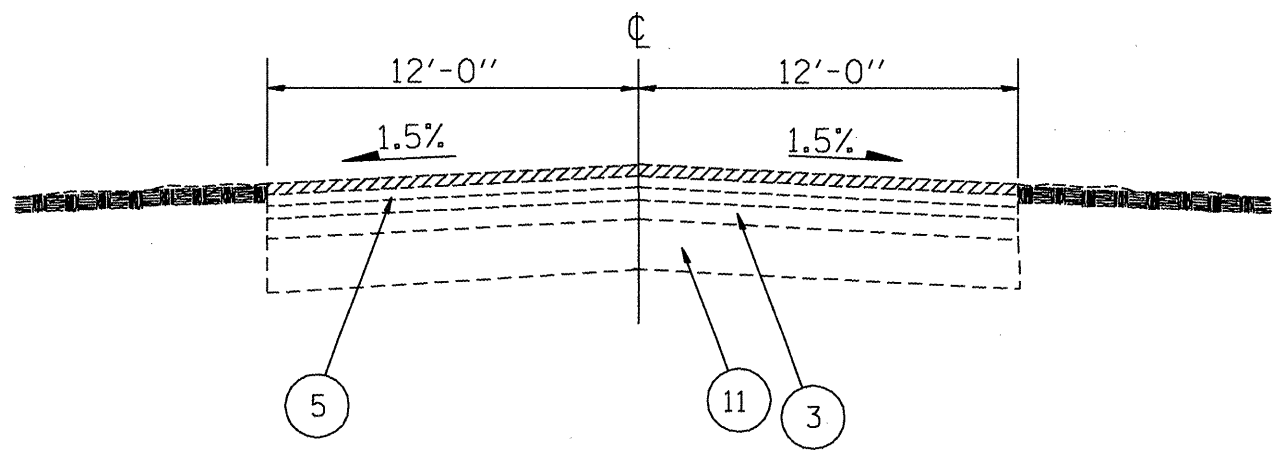

STA 56+60 - 56+85

- PROP HMA SURF REM 3/4"
- PROP HMA SURF REM 2"

LEGEND

- 1 EXIST 9-6-9 PAVEMENT
- 2 EXIST LEVELING BINDER, MIX C, 3/4"
- 3 EXIST LEVELING BINDER, VAR. THICKNESS
- 4 EXIST BCSC, MIX D, CLASS I, 1-1/2"
- 5 EXIST BIT. OVERLAY (1-1/2" BINDER, 1-1/2" SURFACE)
- 6 EXIST BIT OVERLAY (1-1/2" BINDER, 1-1/4" SURFACE)
- 7 EXIST CCC&G B-6.18
- 8 EXIST CCC&G B-6.12
- 9 EXIST CONCRETE MEDIAN
- 10 EXIST CONCRETE & BRICK PAVEMENT
- 11 EXIST PCC BASE COURSE 9"
- 12 EXIST AGG BASE COURSE, 4"
- 13 EXIST AGG SHOULDER
- 14 EXIST CONCRETE GUTTER
- 15 GRAN SUB-BASE, TYPE B, 6"
- 16 POROUS GRAN EMBANKMENT, 6"

REVISIONS	
NAME	DATE

ILLINOIS DEPARTMENT OF TRANSPORTATION

**IL 78 EXISTING  
TYPICAL SECTIONS**

SCALE: VERT. \_\_\_\_\_  
HORIZ. \_\_\_\_\_

DATE \_\_\_\_\_ DRAWN BY \_\_\_\_\_  
CHECKED BY \_\_\_\_\_