

WESTBOUND STA. 920+34.73 TO STA. 924+86.73

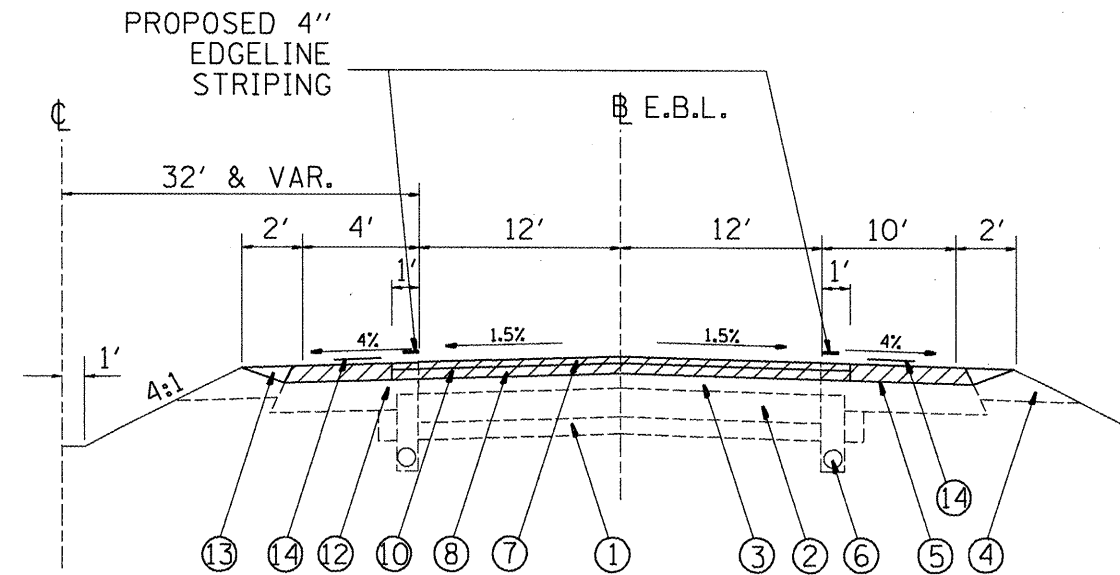

EASTBOUND STA. 920+34.73 TO STA. 924+86.73

SN 090-0077 ϕ STA. 922+60.73
 BEGIN TAPER = STA. 920+34.73
 BEGIN 3.75 IN REMOVAL = STA. 921+84.73
 END 3.75 IN REMOVAL = STA. 923+36.73
 END TAPER = STA. 924+86.73

TYPICAL SECTION 3

NOTE: SEE PAVEMENT OVERLAY UNDER S.N. 090-0077 DETAIL

LEGEND

- ① EXIST. SUB-BASE GRAN. MATERIAL 6"
- ② EXIST. P.C.C. PAVEMENT, 10"
- ③ EXIST. OVERLAY 5 1/2" AVG. THICKNESS
- ④ EXIST. AGGREGATE SHOULDER
- ⑤ EXIST. BIT. SHOULDER
- ⑥ EXIST. PIPE UNDERDRAIN 4"
- ⑦ PROP. HOT MIX ASPHALT SURF. CSE. 1 1/2"
- ⑧ PROP. HOT MIX ASPHALT BINDER COURSE 2 1/4"
- ⑨ PROP. HMA SURFACE REMOVAL (COLD MILLING), 2"
- ⑩ PROP. HMA SURFACE REMOVAL (COLD MILLING), 3 3/4"
- ⑪ PROP. HMA SHOULDER 1 3/4"
- ⑫ PROP. HMA SHOULDER 3 3/4"
- ⑬ PROP. AGGREGATE SHOULDER TYPE "B"
- ⑭ PROPOSED RUMBLE STRIPS

TYPICAL SECTION

MEDIAN CROSSOVERS
 MEDIAN STA. 675+65 AND 830+93
 (SEE MEDIAN CROSSOVER DETAIL SHEET)

NOTE:

BRIDGE OMISSION
 SN 090-0021, 0022
 STA. 644+27.11
 SN 090-0023, 0024
 STA. 905+20.00

STRUCTURES OVER I-74

SN 090-0084
 STA. 686+89.76
 SN 090-0075
 STA. 765+17.14
 SN 090-0077
 STA. 922+60.73

FILE NAME = I-74 Morton General File.dgn	USER NAME = kilmank	DESIGNED -	REVISED -	STATE OF ILLINOIS DEPARTMENT OF TRANSPORTATION	I-74 PROPOSED TYPICAL SECTIONS	F.A.I. RTE. 74	SECTION (90-15IRS-3)	COUNTY TAZEWELL	TOTAL SHEETS 60	SHEET NO. 9	
	PLOT SCALE = 100.0000' / IN.	DRAWN -	REVISED -			NOT TO SCALE	SHEET NO. 2 OF 2 SHEETS	STA. 634+64.00 TO STA. 973+20.00		CONTRACT NO. 68508	
	PLOT DATE = 2/11/2009	CHECKED -	REVISED -			ILLINOIS FED. AID PROJECT					
		DATE -	REVISED -								