

| | | | | |
|---------------------|---------|---------------------------|--------------|-----------|
| F.A. RTE. | SECTION | COUNTY | TOTAL SHEETS | SHEET NO. |
| | | | 101 | 101 |
| STA. | | TO STA. | | |
| FED. ROAD DIST. NO. | | ILLINOIS FED. AID PROJECT | | |

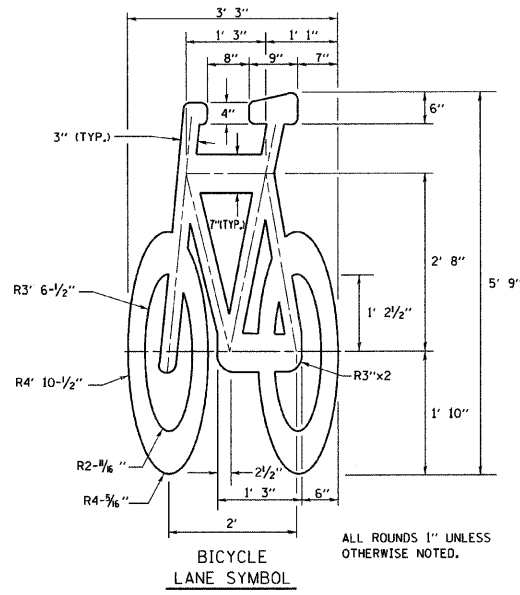
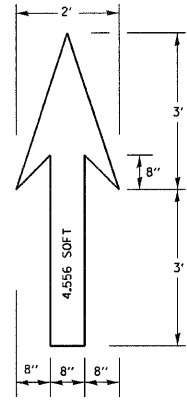

NOTE:

- FOR BIKE LANE SYMBOLS ONLY, USE PRE-FORMED THERMOPLASTIC WITH A MINIMUM THICKNESS OF 90 MILS, MINIMUM SKID RESISTANCE VALUE OF 60 BPN, & A MINIMUM INDEX OF REFRACTION OF 1.50.
- THE RESIDENT ENGINEER SHALL CONTACT MR. BEN GOMBERG AT 312-744-8093 AT LEAST ONE CALENDAR WEEK PRIOR TO INSTALLING BIKE LANE SYMBOLS.

TYPICAL BIKE LANE SYMBOLS
DRAWING #28

DRAWING #29

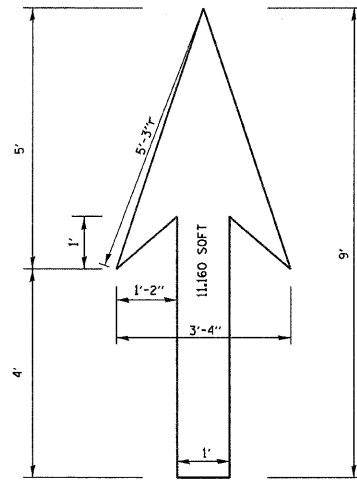

DRAWING #30

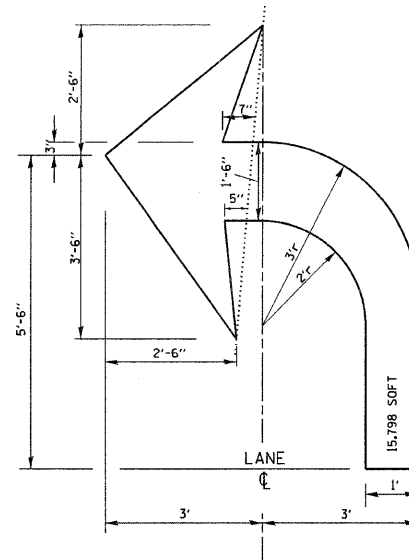

DRAWING #31

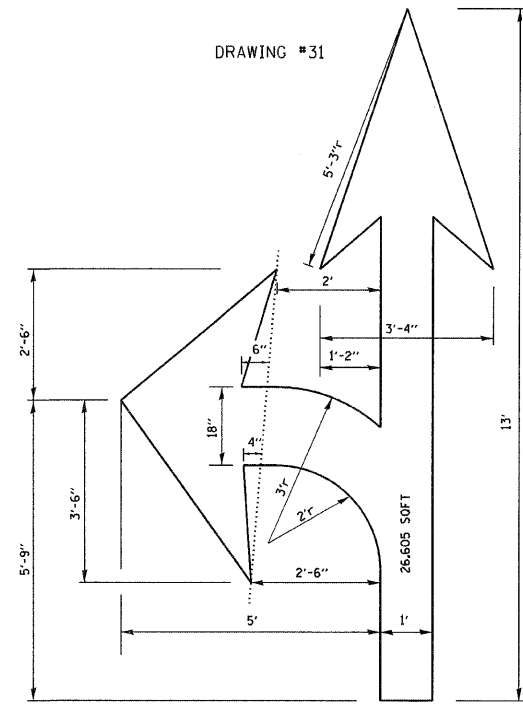

DRAWING #32

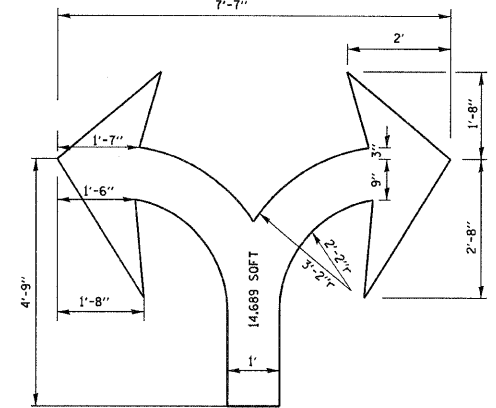

DRAWING #33

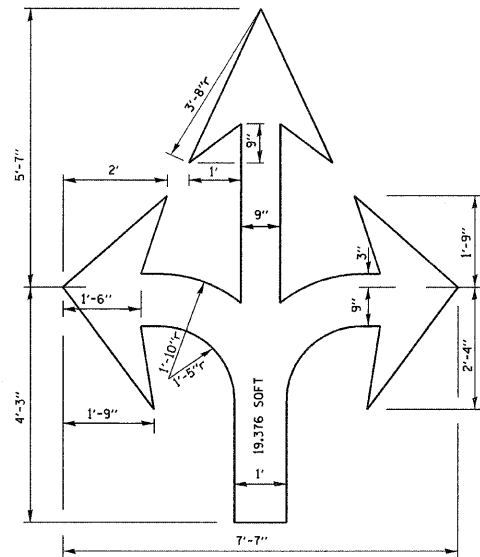

DRAWING #34

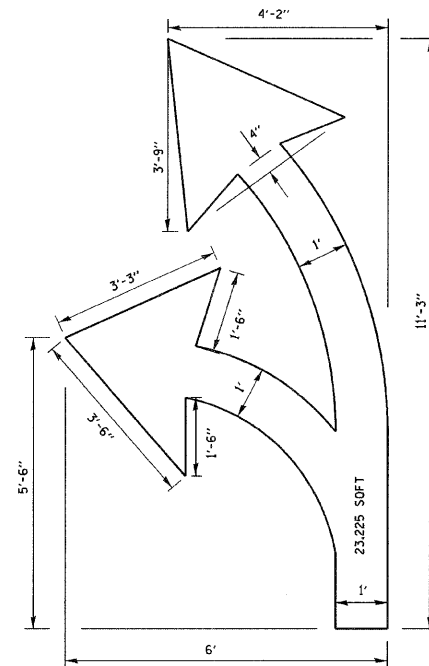

DRAWING #35

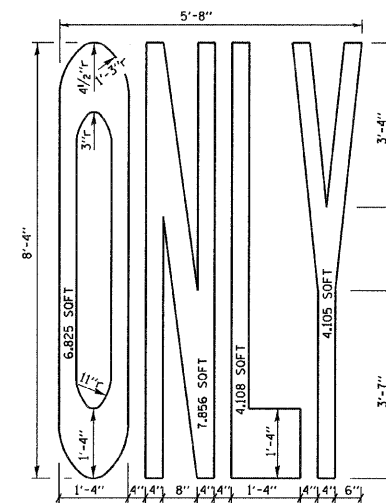

NOTE:

ALL MARKINGS SHALL BE SOLID WHITE UNLESS OTHERWISE NOTED IN THE PLANS

| REVISIONS | |
|--------------|----------|
| NAME | DATE |
| T. RAMMACHER | 12/07/00 |
| | |
| | |
| | |
| | |
| | |
| | |
| | |
| | |

ILLINOIS DEPARTMENT OF TRANSPORTATION

CITY OF CHICAGO
TYPICAL PAVEMENT
MARKINGS

SCALE: NONE

DRAWN BY
CHECKED BY
TC-24