

PLAN

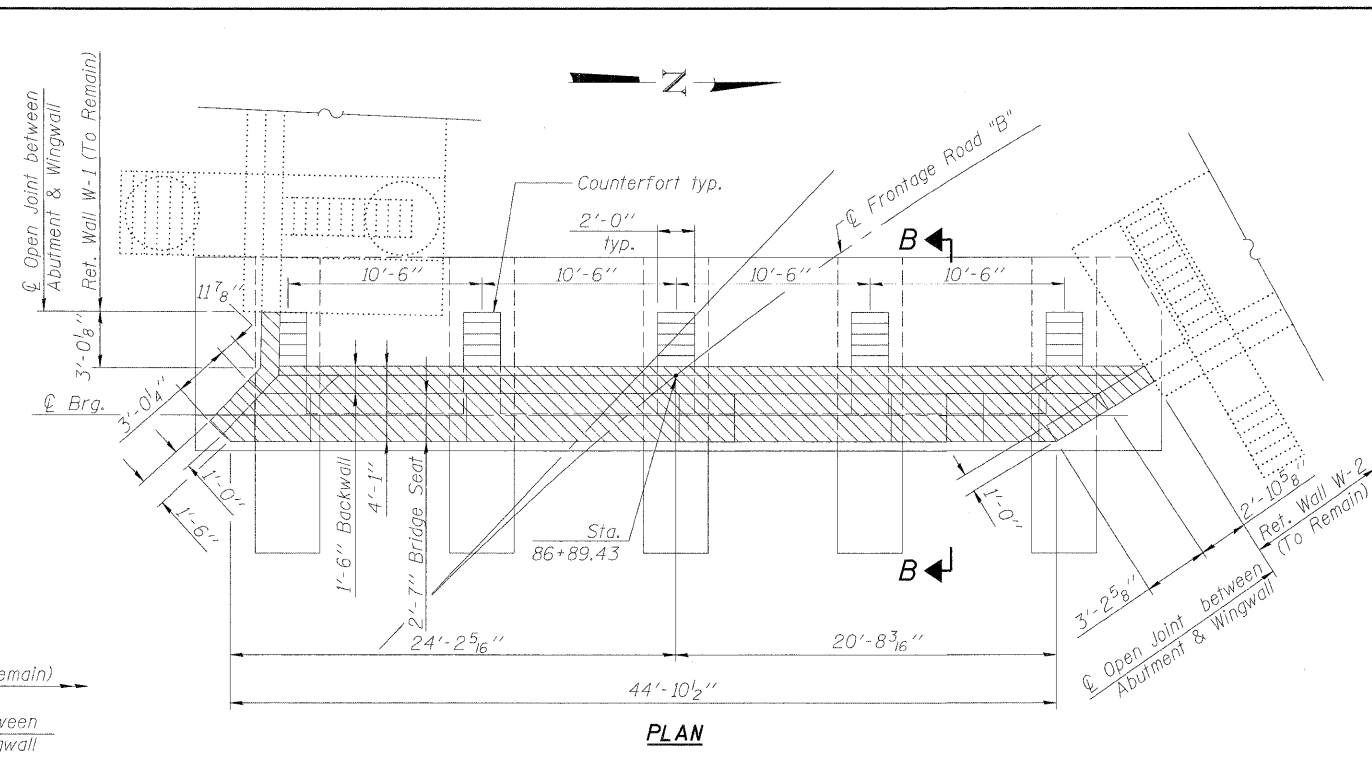

PLAN

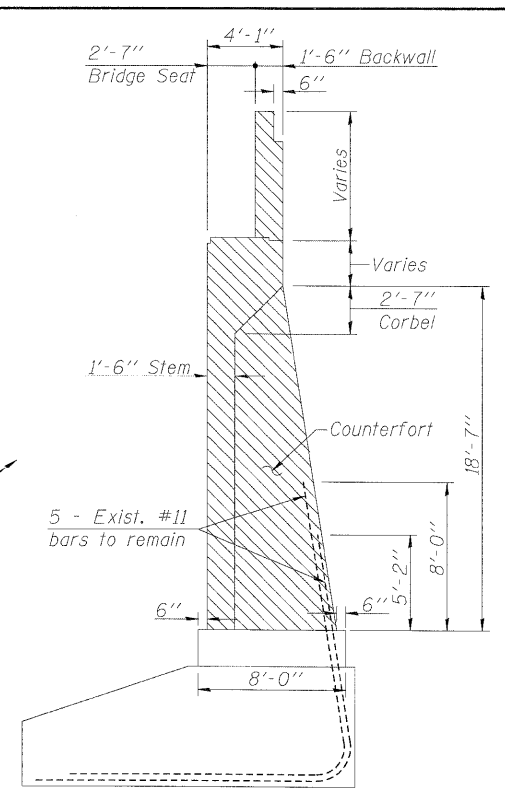

SECTION A-A

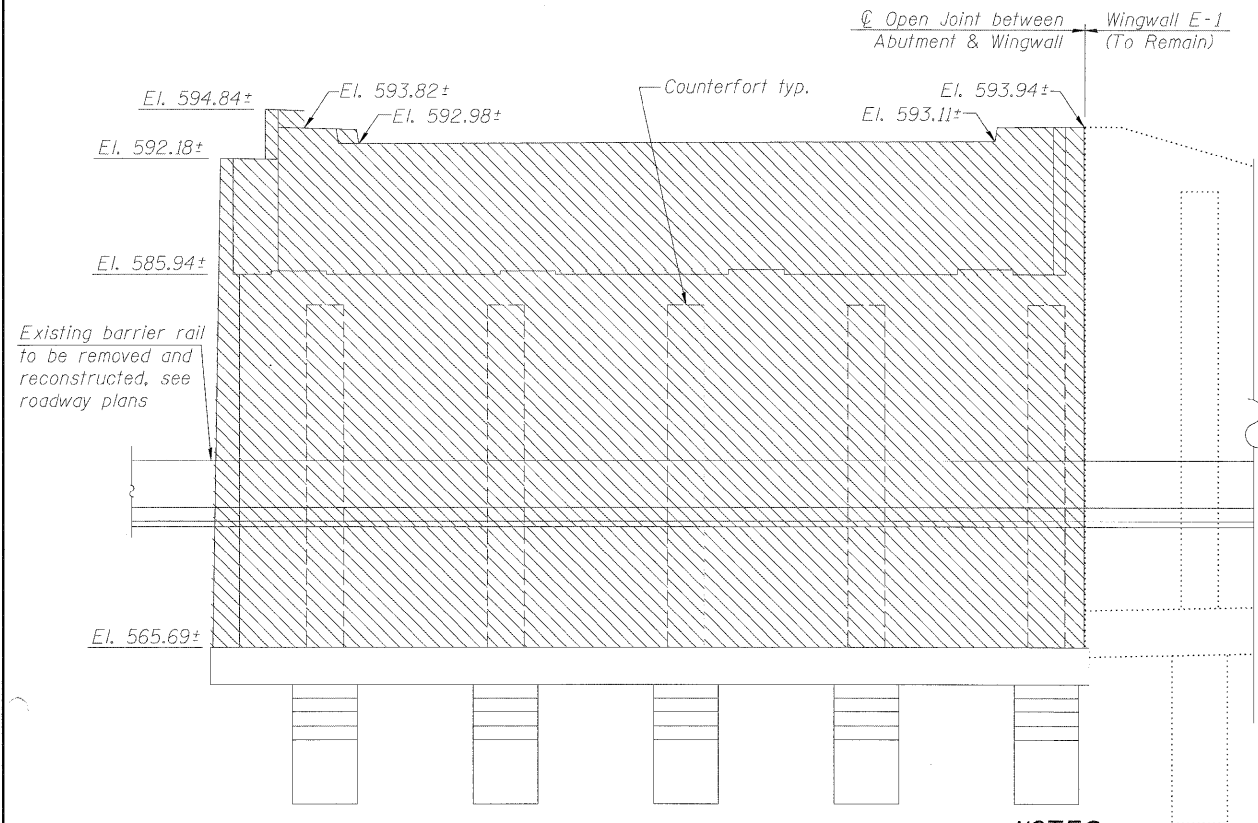

**ELEVATION
ABUTMENT C**

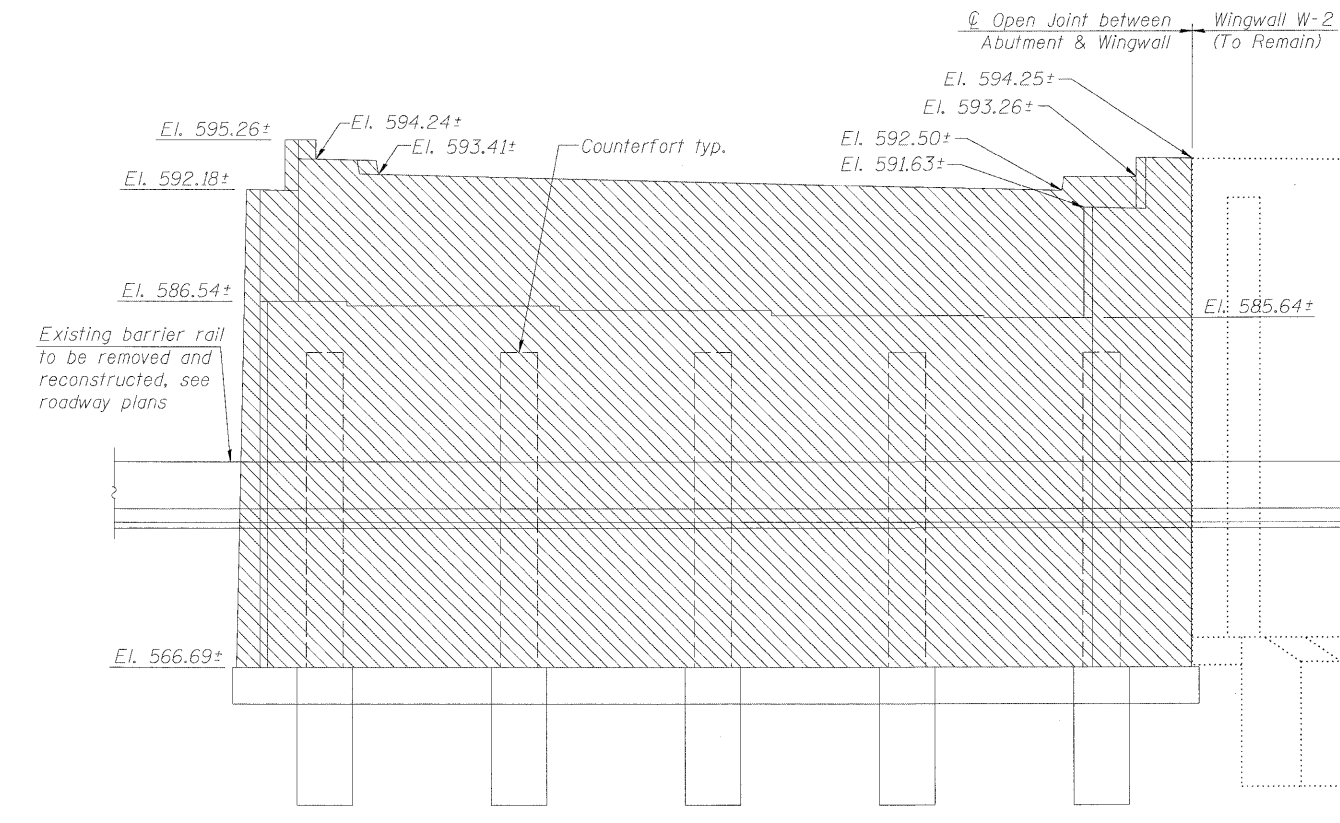

**ELEVATION
ABUTMENT D**

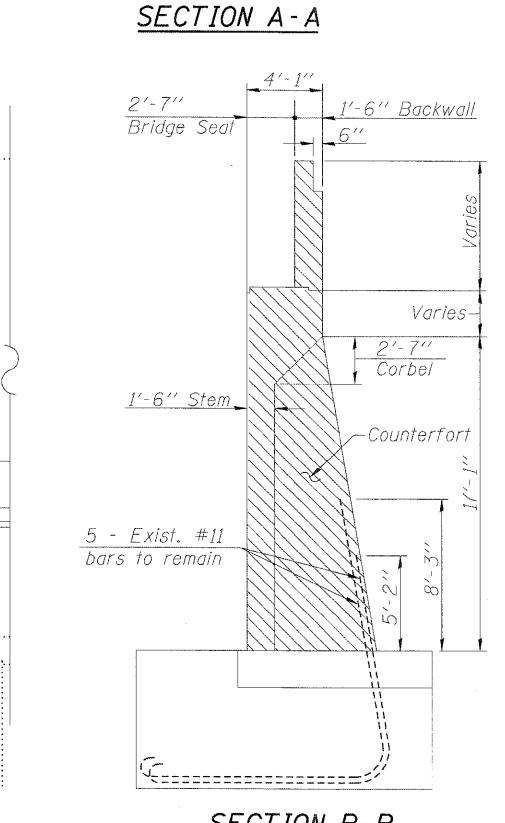

SECTION B-B

NOTES:

- Existing reinforcement steel extending into removal area shall be cleaned, straightened and incorporated into the new construction. Costs shall be included in Concrete Removal.
- Any reinforcement bars being reused that are damaged during concrete removal operations shall be repaired or replaced using an approved bar splicer or anchorage system. Costs shall be included in Concrete Removal.
- Bill of Material includes Concrete Removal quantities for Abutments C and D.
- Portion of existing fence shall be removed and reinstalled. Costs shall be included in Concrete Removal.

Legend:
 Concrete Removal

BILL OF MATERIAL

Item	Unit	Quantity
Concrete Removal	Cu. Yd.	220