

When "A" is 3'-6" or less, the temporary concrete barrier shall be anchored to the new slab according to Detail I or Detail II. No anchorage is required when "A" is greater than 3'-6".

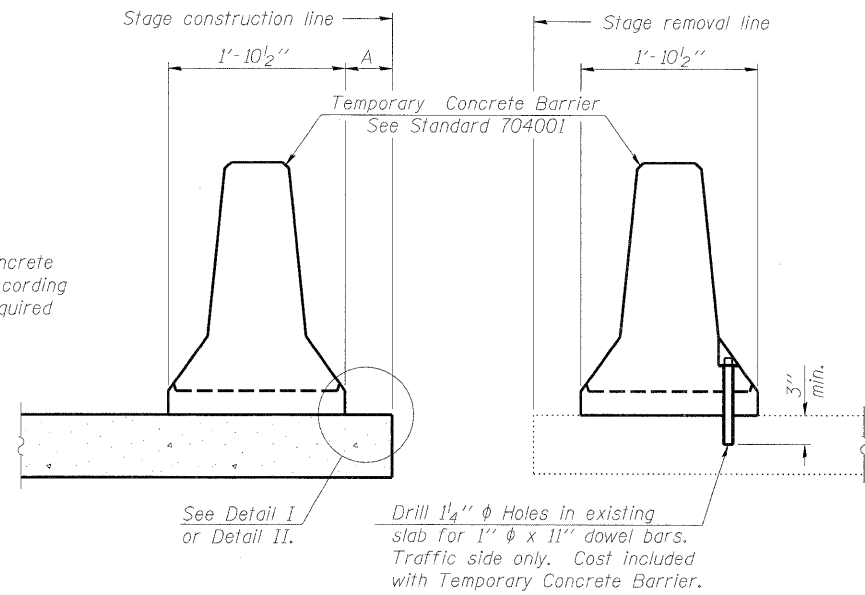

NEW SLAB

EXISTING SLAB

SECTIONS THRU SLAB

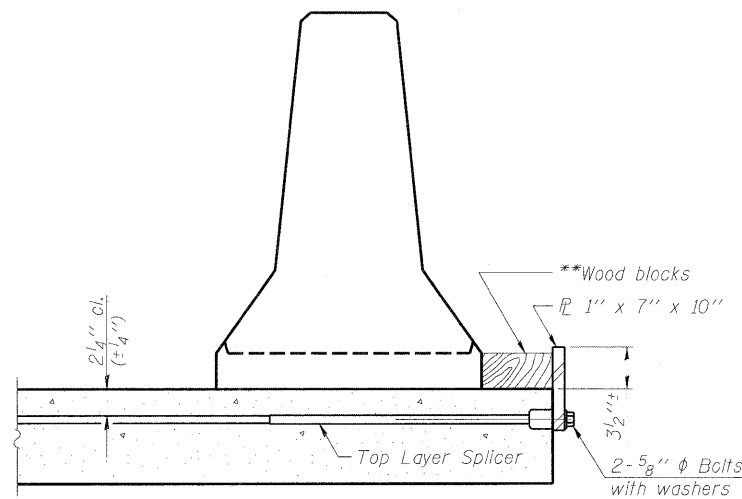

DETAIL I

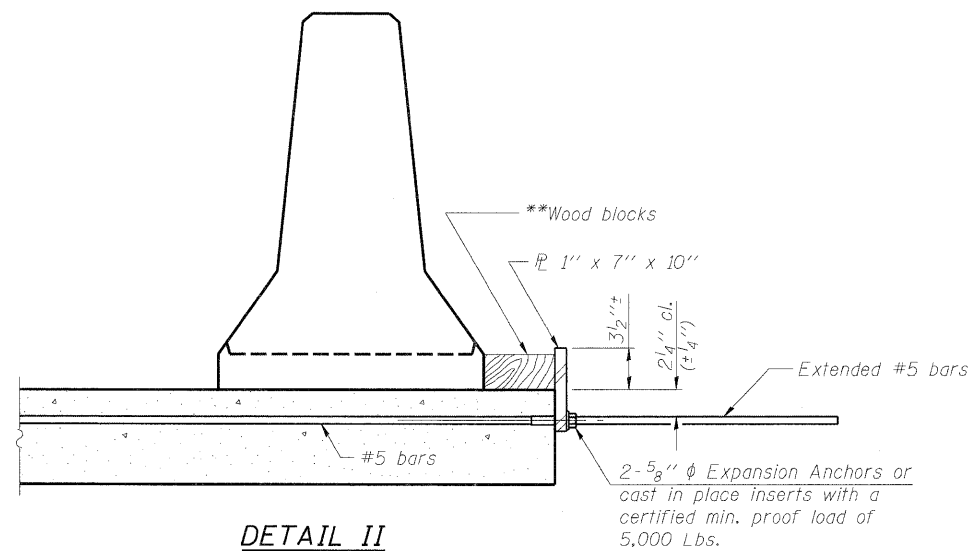

DETAIL II

** Wood blocks may be omitted when required to provide minimum stage traffic lane width. When the wood blocks are omitted, the concrete barrier shall be in direct contact with the steel retainer plate.

NOTES:

1. Detail I - With Bar Splicer or Couplers: Connect one (1) 1"x7"x10" steel PL to the top layer of couplers with 2-5/8" φ bolts screwed to coupler at approximate CL of each barrier panel.
2. Detail II - With Extended Reinforcement Bars: Connect one (1) 1"x7"x10" steel PL to the concrete slab with 2-5/8" φ Expansion Anchors or cast in place inserts spaced between the top layer of reinforcement at approximate CL of each barrier panel.
3. Cost of anchorage is included with Temporary Concrete Barrier.
4. The 1" x 7" x 10" plate shall not be removed until stage II construction forms and all reinforcement bars are in place and the concrete is ready to be placed.

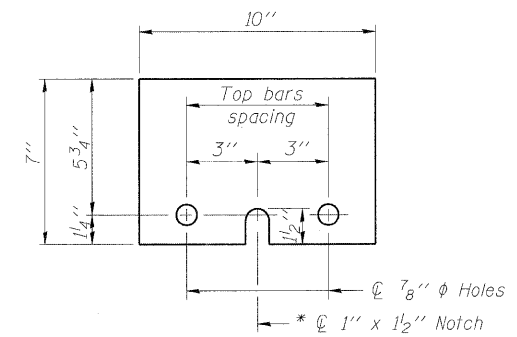

STEEL RETAINER PL 1" x 7" x 10"

* Required only with Detail II