

MILLED TEMPORARY RAMP  
(FOR BUTT JOINT AND HMA TAPER SEE DETAIL BELOW)

**OPTION 1**

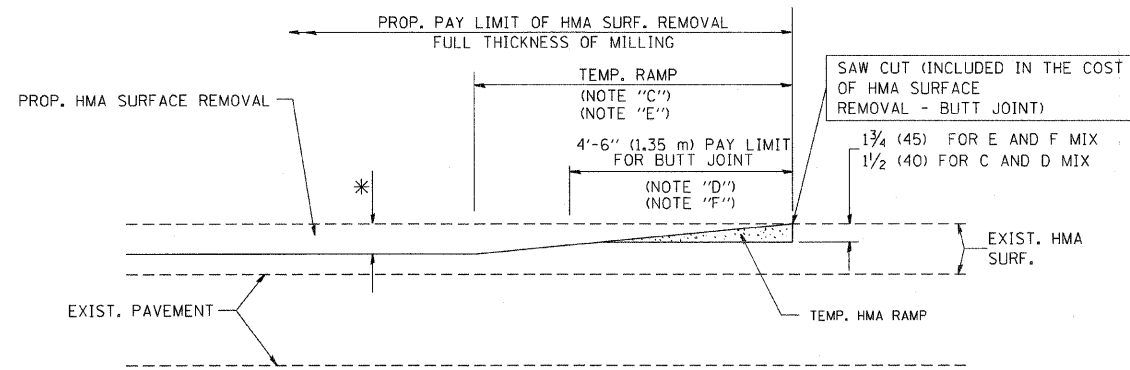

HMA CONSTRUCTED TEMPORARY RAMP  
(FOR BUTT JOINT AND HMA TAPER SEE DETAIL BELOW)

**OPTION 2**

**TYPICAL TEMPORARY RAMP**

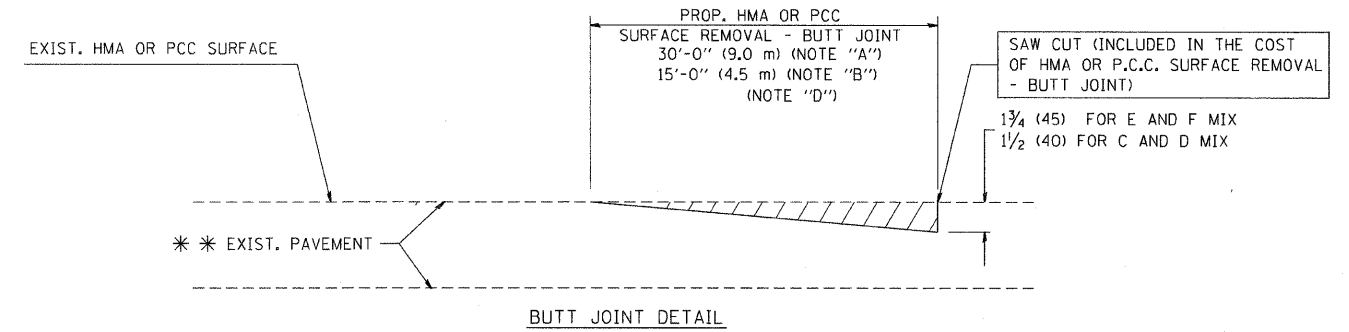

**BUTT JOINT DETAIL**

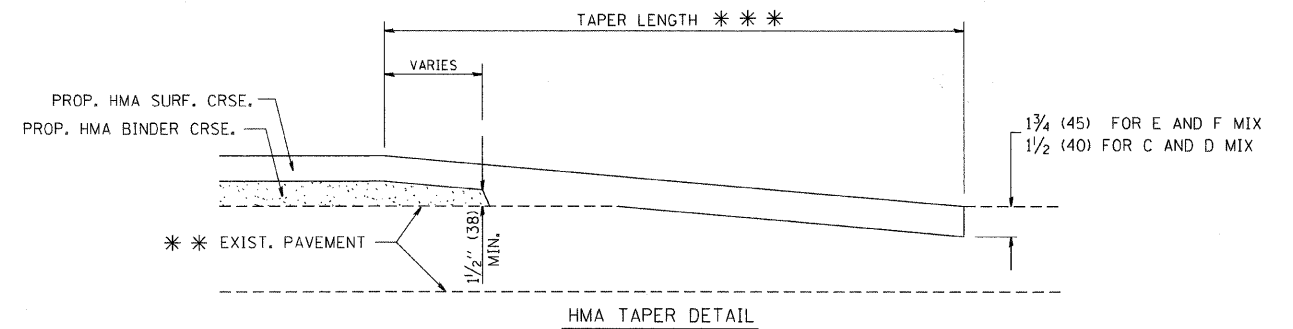

**HMA TAPER DETAIL**

**TYPICAL BUTT JOINT AND HMA TAPER FOR RESURFACING ONLY**

\*\*\* PC CONCRETE, HMA OR HMA RESURFACED PAVEMENT.

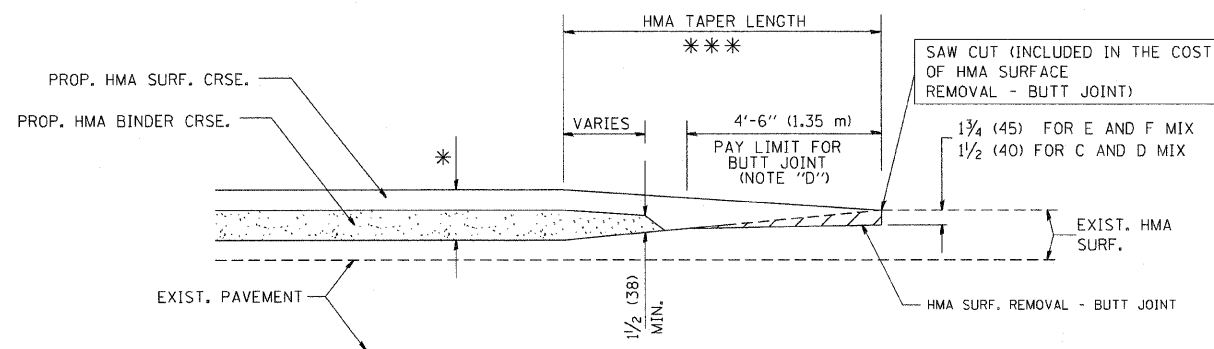

**BUTT JOINT AND HMA TAPER**

**TYPICAL BUTT JOINT AND HMA TAPER FOR MILLING AND RESURFACING**

**NOTES**

- A: MAINLINE ROADWAYS AND MAJOR SIDE ROADS.
  - B: MINOR SIDE ROADS.
  - C: THE TEMP. RAMP SHALL BE CONSTRUCTED IMMEDIATELY UPON REMOVAL OF THE EXISTING HMA SURFACE.
  - D: THE BUTT JOINT SHALL BE CONSTRUCTED IMMEDIATELY PRIOR TO PLACING THE PROPOSED HMA COURSES.
  - E: TAPER THE TEMP. RAMP AT A RATE OF 3'-0" (900 mm) PER 1 INCH (25 mm) OF MILLING THICKNESS.
  - F: INSTALLATION AND REMOVAL OF THE 4'-6" (1.35 m) TEMP. RAMP IS INCLUDED IN COST OF HMA SURFACE REMOVAL - BUTT JOINT
  - G: SEE ARTICLE 406.08 AND 406.14 OF THE STANDARD SPECIFICATIONS FOR "HMA AND/OR PCC SURFACE REMOVAL, BUTT JOINT".
- \* SEE TYPICAL SECTIONS FOR MILLING THICKNESS.
- \*\*\* 20'-0" (6.1 m) PER 1 (25) RESURFACING (NOTE "A")  
10'-0" (3.0 m) PER 1 (25) RESURFACING (NOTE "B")

**BASIS OF PAYMENT:**

THE BUTT JOINT WILL BE PAID FOR AT THE CONTRACT UNIT PRICE PER SQUARE YARD (SQUARE METER) FOR "HOT-MIX ASPHALT SURFACE REMOVAL - BUTT JOINT" OR FOR "PORTLAND CEMENT CONCRETE SURFACE REMOVAL - BUTT JOINT".

ALL DIMENSIONS ARE IN INCHES (MILLIMETERS) UNLESS OTHERWISE SHOWN.

|  |                             |                       |                             |
|--|-----------------------------|-----------------------|-----------------------------|
| FILE NAME =<br>W:\diststd\22x34\bd32.dgn | USER NAME = gogliobst       | DESIGNED - M. DE YONG | REVISED - R. SHAH 10-25-94  |
|  |                             | DRAWN -               | REVISED - A. ABBAS 03-21-97 |
|  | PLOT SCALE = 50.0000 "/ IN. | CHECKED -             | REVISED - M. GOMEZ 04-06-01 |
|  | PLOT DATE = 1/4/2008        | DATE - 06-13-90       | REVISED - R. BORO 01-01-07  |

**STATE OF ILLINOIS  
DEPARTMENT OF TRANSPORTATION**

**BUTT JOINT AND  
HMA TAPER DETAILS**

SCALE: NONE SHEET NO. 1 OF 1 SHEETS STA. TO STA.

|   |             |        |                    |           |
|---|-------------|--------|--------------------|-----------|
| F.A.P. RTE.                                     | SECTION     | COUNTY | TOTAL SHEETS       | SHEET NO. |
| 370   | 2008-005 RS | COOK   | 22                 | 15        |
| BD400-05 BD32                                   |             |        | CONTRACT NO. 60E29 |           |
| FED. ROAD DIST. NO. 1 ILLINOIS FED. AID PROJECT |             |        |                    |           |