

P.A.L. NTE.	SECTION	COUNTY	TOTAL SHEETS	SHEET NO.
34		COOK	133	130
STA. _____ TO STA. _____		ILLINOIS FDS. AID PROJECT		

• (0405,ETC,42-780707RS-11

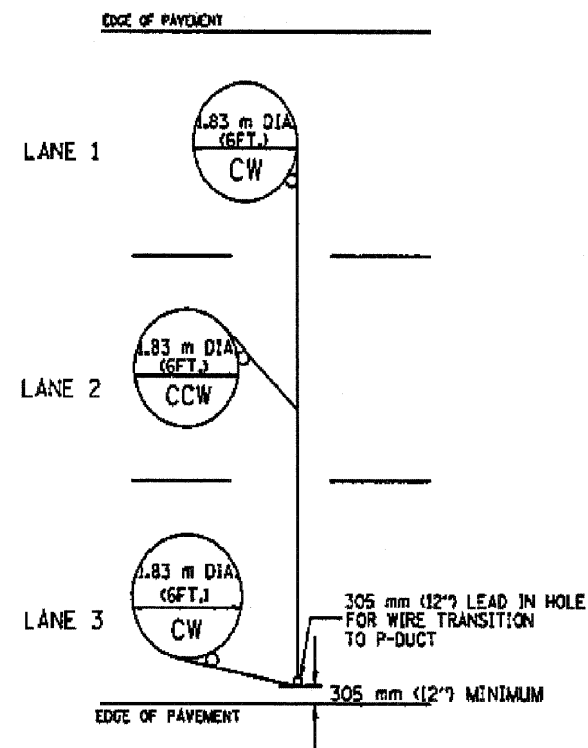

TYPICAL 1.83 m (6FT.) DIA. INDUCTION LOOP CORE DRILL LAYOUT FOR MULTIPLE LANE ROADWAY

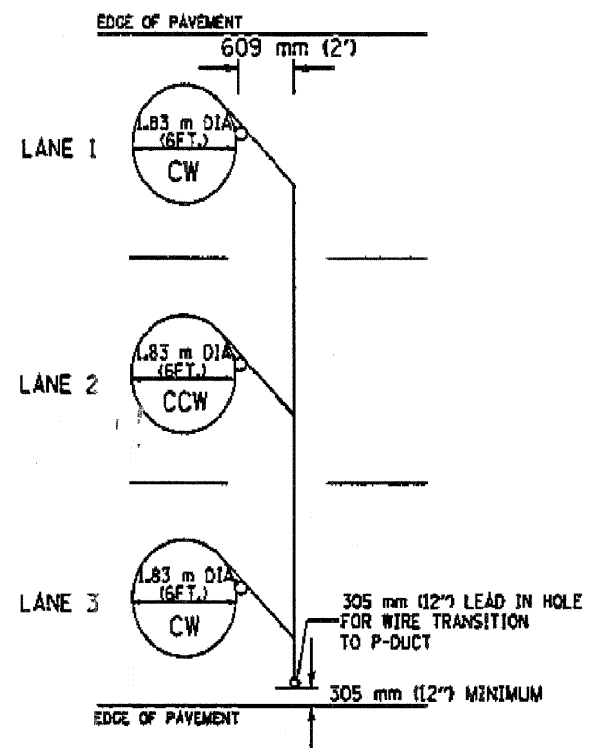

TYPICAL 1.83 m (6FT.) DIA. INDUCTION LOOP CORE DRILL LAYOUT FOR MULTIPLE LANE ROADWAY

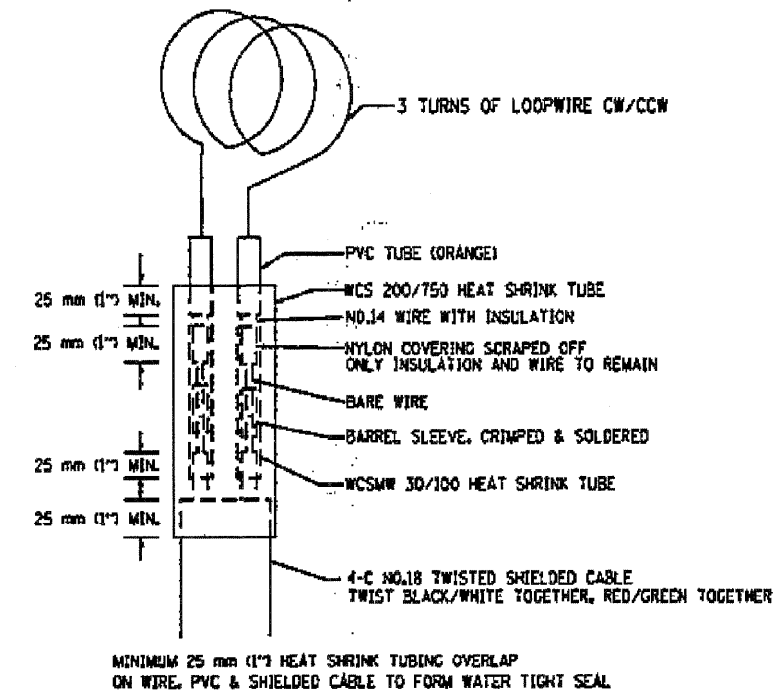
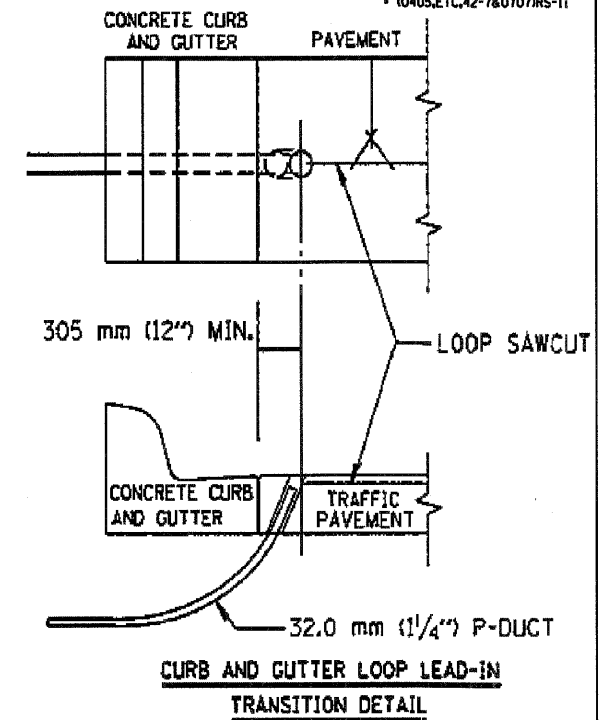

LOOP SPLICING REQUIREMENTS

- NOTES**
1. EACH LOOP SHALL BE SPLICED TO A 4-C NO.18 TWISTED SHIELDED LEAD IN WHEN 45 m (150FT.) OR MORE FROM CABINET.
 2. LOOPS SHALL BE SPLICED IN HANDHOLES ONLY, OTHERWISE WRITTEN PERMISSION SHALL BE OBTAINED FROM TSC ENGINEER.
 3. LOOPS SHALL NOT BE SPLICED IN SERIES.
 4. EACH LOOP LEAD IN SHALL BE IDENTIFIED AND PERMANENTLY COLOR CODED IN THE COREHOLE, HANDHOLE & CABINETS THRU WHICH THEY ENTER OR PASS AND TAGGED WITH THE CORRECT NOMENCLATURES.

REVISIONS	
NAME	DATE
R.L.	6/94
T.C.	10/96

ILLINOIS DEPARTMENT OF TRANSPORTATION
 TRAFFIC SYSTEMS CENTER
**EXISTING
 ROUND INDUCTION LOOP
 TYPICALS**
 SCALE: VERT. NONE
 DATE: 6-22-94
 DRAWN BY: GW
 CHECKED BY: R.L.

D:\60D21-130-DISTRICT DETAILS.dgn

NO. TYPE L.DG4 86

VI-418C