

\*\* AFTER TIGHTENING, CUT THE ANCHOR BOLTS FLUSH WITH THE NUTS AND DAMAGE THE NUTS TO PREVENT THEM FROM LOOSENING.

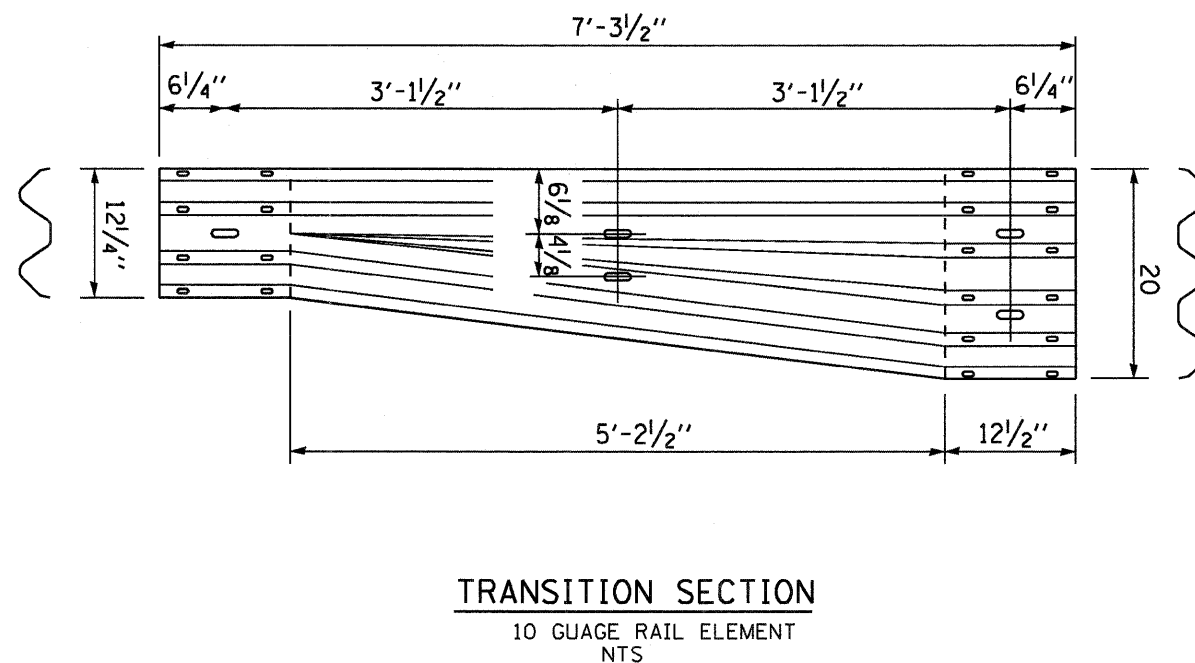
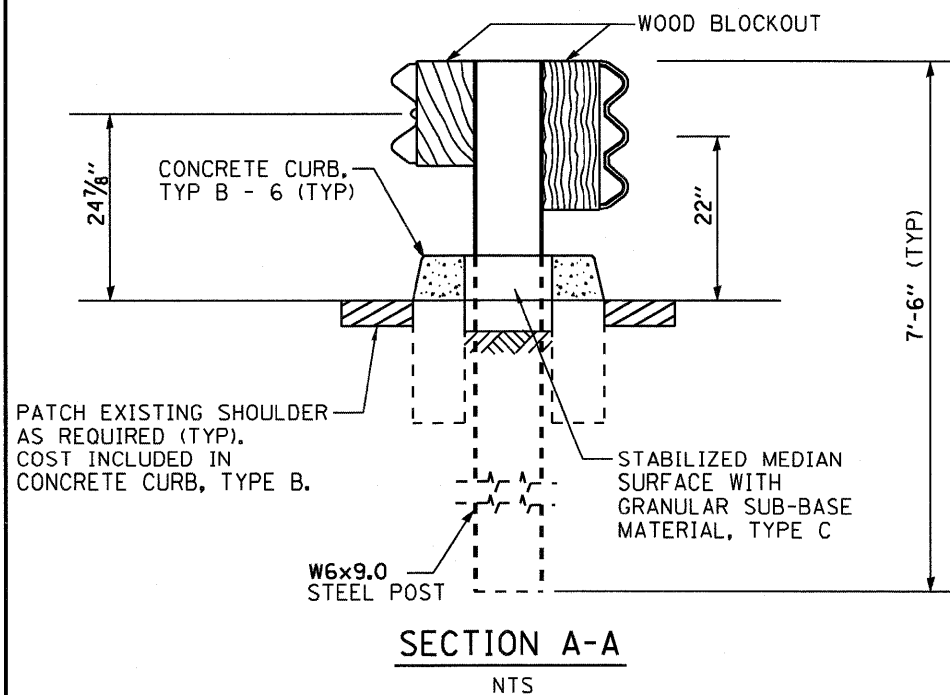

GENERAL NOTES

WORK SHALL BE PERFORMED PER SECTIONS 630 AND 631 OF THE STANDARD SPECIFICATIONS.

SEE STANDARD 630001 FOR DETAILS OF GUARDRAIL NOT SHOWN.

THRIE BEAM RAIL SHALL BE BOLTED TO BLOCKOUT AT ALL POSTS.

FILE NAME = DI60021-105-BARRIER_TRANSITION_DETAIL.dwg	USER NAME = dvoznizoraki	DESIGNED -	REVISED -	<b>STATE OF ILLINOIS DEPARTMENT OF TRANSPORTATION</b>	<b>BISHOP FORD EXPRESSWAY (I-94) TRAFFIC BARRIER TERMINAL TYPE 6 (SPECIAL)</b>	F.A.I. RTE.	SECTION	COUNTY	TOTAL SHEETS	SHEET NO.	
PLOT SCALE = N/A	DRAWN - DMW, CDS	CHECKED -	REVISED -			94	(0405,ETC,42-7&0707RS-11	COOK	133	105	
PLOT DATE = 2/5/2009	DATE - 2/5/2009	CHECKED -	REVISED -			SCALE: N/A SHEET NO. 1 OF 2 SHEETS STA. TO STA.		CONTRACT NO. 60021			
						FED. ROAD DIST. NO. ILLINOIS FED. AID PROJECT					