

STAGE III AND IV: YEAR 2010

STAGE IV

STAGE IV NOTES

- SEQUENCE OF CONSTRUCTION: PAVEMENT PATCHING, HMA SURFACE REMOVAL AND PROPOSED HMA COURSES. WORK CAN OCCUR CONCURRENTLY, BUT SEQUENCE SHALL BE MAINTAINED AND NOT CONFLICT. RAMP WORK WILL BE COMPLETED USING DISTRICT DETAIL TC-8 - FREEWAY AND EXIT RAMP CLOSURE DETAILS.
- LANE AND RAMP CLOSURES ALLOWED AS STIPULATED IN THE SPECIAL PROVISIONS.
- LANE CLOSURES PER STANDARDS 701400, 701401 AND 701446.
- REDUCE LANE WIDTH USING 35:1 TAPER PER DISTRICT DETAIL TC-9 - TRAFFIC CONTROL DETAILS FOR FREEWAY SINGLE AND MULTI-LANE WEAVE. A W5-1 (48 x 48) ROAD NARROWS SIGN WILL BE ERRECTED 500' IN ADVANCE OF THE TAPER.
- THE CONTRACTOR SHALL ERECT ROAD CONSTRUCTION AHEAD SIGNS (W20-1103(0-48)) WITH FLASHING BEACON ON ALL ARTERIAL ROADWAYS APPROACHING INTERCHANGE RAMPS.
- GRADE DIFFERENTIAL BETWEEN LANES SHALL NOT EXCEED 2-1/2".
- PARTIAL MILLING OF PAVEMENT FOR AN OPERATION WILL NOT BE PAID FOR SEPARATELY, BUT WILL BE PAID FOR AT THE FINAL MILLING THICKNESS SHOWN ON THE TYPICAL SECTIONS.
- REMOVAL OF TEMPORARY PAVEMENT MARKING, WHEN REQUIRED, SHALL BE PAID FOR AS "WORK ZONE PAVEMENT MARKING REMOVAL".
- REMOVAL OF EXISTING PAVEMENT MARKING, WHEN REQUIRED, SHALL BE PAID FOR AS "PAVEMENT MARKING REMOVAL".
- EXISTING OR TEMPORARY PAVEMENT MARKINGS REMOVED DURING MILLING OPERATIONS WILL NOT BE PAID FOR SEPARATELY.
- CASTINGS EXPOSED IN TRAVEL LANES SHALL BE PROTECTED PER APPLICABLE PORTIONS OF ARTICLE 603.07 OF THE STANDARD SPECIFICATIONS. THIS WORK WILL NOT BE PAID FOR SEPARATELY, BUT SHALL BE INCLUDED IN THE VARIOUS HMA BINDER AND SURFACE COURSES PLACED.

LEGEND

- ① EXISTING PAVEMENT MARKING
- ② WET REFLECTIVE TEMPORARY TAPE, TYPE III, 5" (WHITE 10' DASH - 30' SKIP)
- ③ WET REFLECTIVE TEMPORARY TAPE, TYPE III, 4" (YELLOW LEFT & WHITE RIGHT) INSTALLED WITHIN 24 HOURS OF MILLING OR BINDER PLACEMENT.
- ④ EPOXY PAVEMENT MARKING. LIMITED TO AREA IMPACTED BY STAGE I & II SEE PAVEMENT MARKING PLANS FOR COLOR AND WIDTH.
- ⑤ VERTICAL BARRICADES WITH STEADY BURNING MONO DIRECTIONAL LIGHT AT 100' C-C SPACING. VERTICAL BARRICADES ALONG SHOULDERS WILL REMAIN IN PLACE BETWEEN OPERATIONS WHEN ALL LANES ARE OPEN TO TRAFFIC. DURING EACH OPERATION VERTICAL BARRICADES WILL THEN BE MOVED TO SEPARATE THE WORK ZONE AND OPERATING LANES.
- ⑥ PROPOSED PAVEMENT MARKING. SEE PAVEMENT MARKING PLANS.

▨ BITUMINOUS SURFACE REMOVAL

▩ HMA SURFACE COURSE

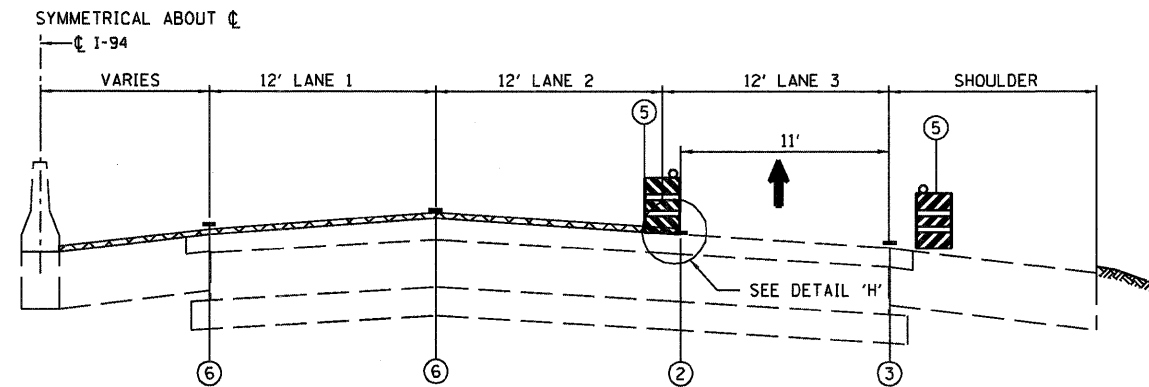

STAGE IV- OPERATION ONE
PLACE SURFACE 1-3/4" - LANES 1 & 2
AND INSIDE SHOULDER

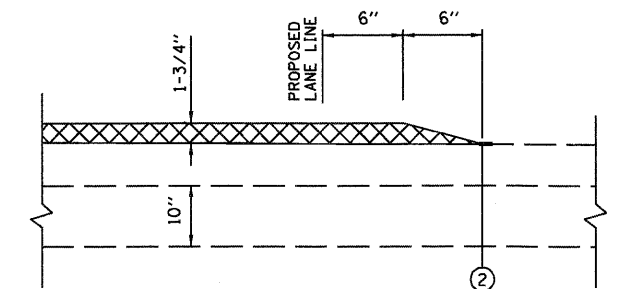

DETAIL 'H'

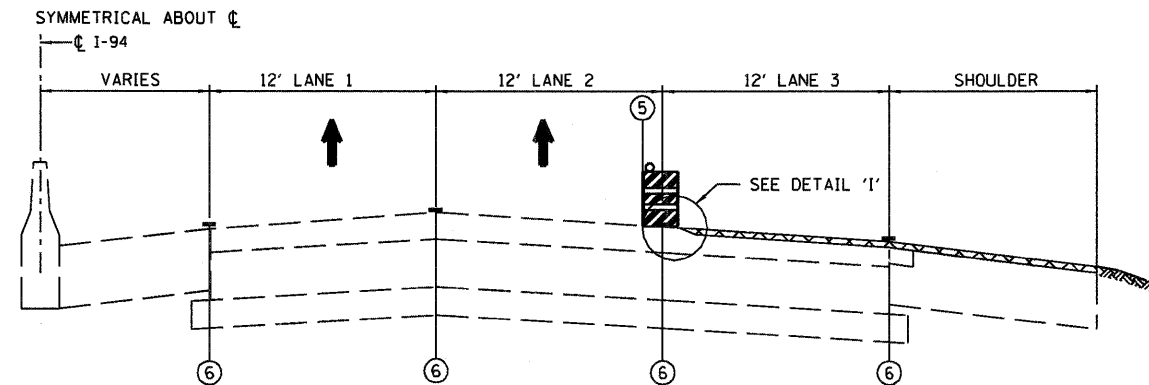

STAGE IV - OPERATION TWO
PLACE 1-3/4" SURFACE - LANE 3
AND OUTSIDE SHOULDER

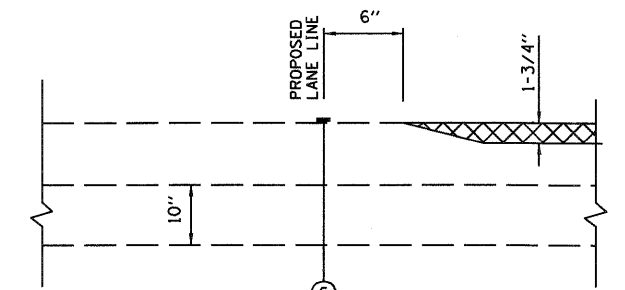

DETAIL 'I'

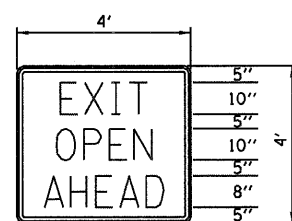

1" BORDER LINE
GREEN REFLECTIVE BACKGROUND
WITH WHITE LEGEND

THIS SIGN SHALL BE INSTALLED
IN ADVANCE OF ALL OPEN/EXIT
RAMPS WHEN THE RIGHT
LANES ARE CLOSED.



W8-11
48" x 48"

NOTE:
THIS SIGN SHALL BE INSTALLED
ON BOTH SIDES OF THE ROADWAY
500' IN ADVANCE OF AREAS WHERE
THERE IS A GRADE DIFFERENTIAL
BETWEEN LANES, AFTER EACH
ENTRANCE RAMP AND MINIMUM
OF EVERY MILE..

FILE NAME = D:\60021-033-STAGE.IV.dgn	USER NAME = dvoznierski	DESIGNED -	REVISED -	STATE OF ILLINOIS DEPARTMENT OF TRANSPORTATION	BISHOP FORD EXPRESSWAY (I-94) SUGGESTED MAINTENANCE OF TRAFFIC	F.A.I. RTE. =	SECTION	COUNTY	TOTAL SHEETS	SHEET NO.
PLOT SCALE = N/A	CHECKED - DMW	REVISED -	94			(0405.ETC.42-7&0707RS-11)	COOK	133	33	
PLOT DATE = 2/5/2009	DATE - 2/5/2009	REVISED -	SCALE: N/A SHEET NO. 5 OF 24 SHEETS STA. TO STA.			CONTRACT NO. 60021				
						FED. ROAD DIST. NO. ILLINOIS FED. AID PROJECT				