

INSIDE ELEVATION OF PARAPET

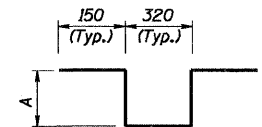

BAR	A
s1(E)	120
s11(E)	220
s2(E)	150
s3(E)	270
s4(E)	170
s5(E)	290
s6(E)	185
s7(E)	310
s8(E)	320
s9(E)	205
s10(E)	300
s11(E)	160

SUPERSTRUCTURE BILL OF MATERIAL

BAR	NO.	SIZE	LENGTH (m)	SHAPE
d(E)	295	#15	12.35	—
a1(E)	225	#15	12.15	—
a2(E)	295	#15	12.50	—
a3(E)	225	#15	12.30	—
a4(E)	128	#15	0.60	—
b(E)	595	#15	8.56	—
b1(E)	944	#15	7.57	—
b2(E)	166	#20	8.78	—
c(E)	374	#15	2.50	—
c1(E)	374	#15	0.73	—
d(E)	380	#15	1.39	—
d1(E)	380	#20	1.31	—
d2(E)	88	#15	0.61	—
d3(E)	12	#20	1.41	—
d4(E)	20	#20	2.68	—
e(E)	24	#15	4.07	—
e1(E)	96	#15	5.87	—
s(E)	181	#15	0.86	—
s1(E)	190	#15	1.06	—
s2(E)	160	#15	0.92	—
s3(E)	367	#15	1.16	—
s4(E)	351	#15	0.96	—
s5(E)	245	#15	1.20	—
s6(E)	127	#15	0.99	—
s7(E)	49	#15	1.24	—
s8(E)	90	#15	1.26	—
s9(E)	504	#15	1.03	—
s10(E)	226	#15	1.22	—
s11(E)	114	#15	0.94	—
Reinforcement Bars, Epoxy Coated	kg	52,500		
Concrete Superstructure	m ³	453.6		

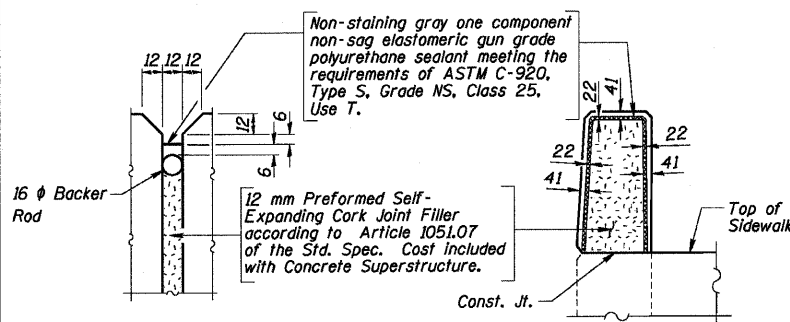

PARAPET JOINT DETAILS

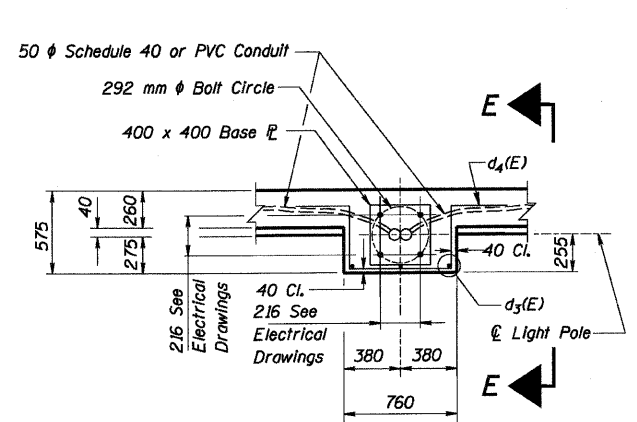
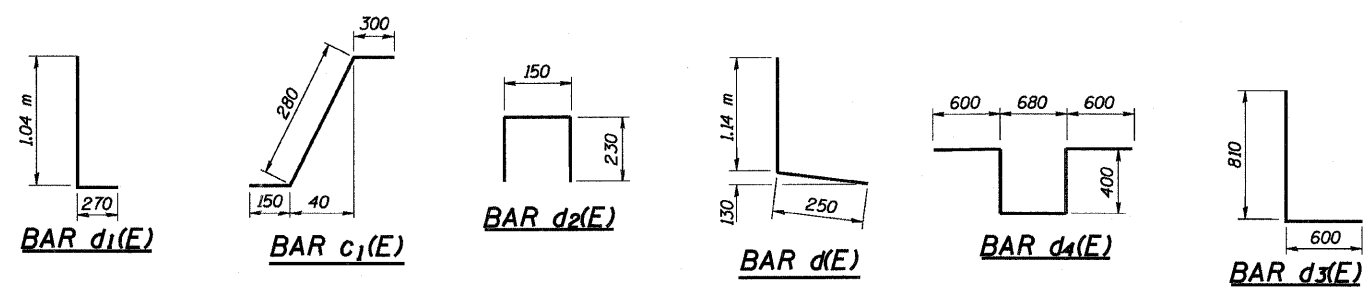

LIGHT POLE PLAN

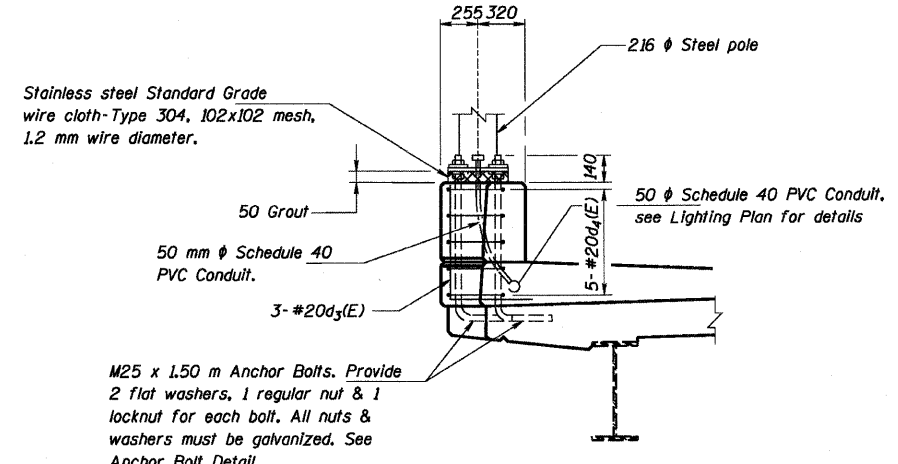

SECTION E-E

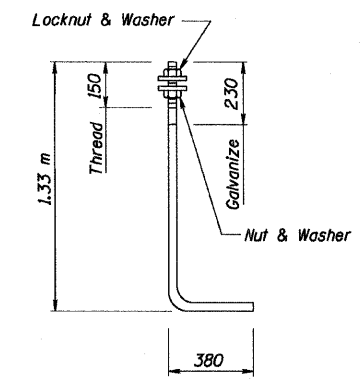

M25 ANCHOR BOLT

Note:
 IDOT Standard Details have been modified to comply with CDOT Standards.

Note:
 Grout mixture shall consist of 1 part sand, 1 part cement and 1 part chips (pea gravel). The grout shall contain water for a 25 slump, cost incidental to pole.
 Cost of anchor bolts and conduit is included with Concrete Superstructure.

REVISIONS	
NAME	DATE

ILLINOIS DEPARTMENT OF TRANSPORTATION
 115 TH. STREET OVER FAI 57
 FAU RTE. 1584 SEC. 068-1919.2-CF
 COOK COUNTY
 STATION 2+382.915
 STRUCTURE NO. 016-2037
SUPERSTRUCTURE DETAILS-III
 DRAWN BY KAC
 CHECKED BY ERB/DGS
 DATE: JANUARY 16, 2009

COLLINS ENGINEERS
 123 North Wacker Drive
 Suite 300
 Chicago, IL 60606
 (312) 704-9300
 www.collinsengr.com
 ILLINOIS PROFESSIONAL DESIGN FIRM LICENSE NO. 184-008993