

STANDARD BAR SPLICER ASSEMBLY

Minimum Lap Lengths					
Bar size to be spliced	Table 1	Table 2	Table 3	Table 4	Table 5
3, 4	1'-5"	1'-11"	2'-1"	2'-4"	2'-3"
5	1'-9"	2'-5"	2'-7"	2'-11"	2'-10"
6	2'-1"	2'-11"	3'-1"	3'-6"	3'-4"
7	2'-9"	3'-10"	4'-2"	4'-8"	4'-6"
8	3'-8"	5'-1"	5'-5"	6'-2"	5'-10"
9	4'-7"	6'-5"	6'-10"	7'-9"	7'-5"

- Table 1: Black bar, 0.8 Class C
- Table 2: Black bar, Top bar lap, 0.8 Class C
- Table 3: Epoxy bar, 0.8 Class C
- Table 4: Epoxy bar, Top bar lap, 0.8 Class C
- Table 5: Epoxy bar, Top bar lap, Class B

Threaded splicer bar length = min. lap length + 1 1/2" + thread length

* Epoxy not required on Bar Splicer Assembly components used in conjunction with black bars.

Location	Bar size	No. assemblies required	Table for minimum lap length
East Approach	#4	12	Table 4
East Approach	#5	42	Table 3
E. Appr. Footing	#5	80	Table 3

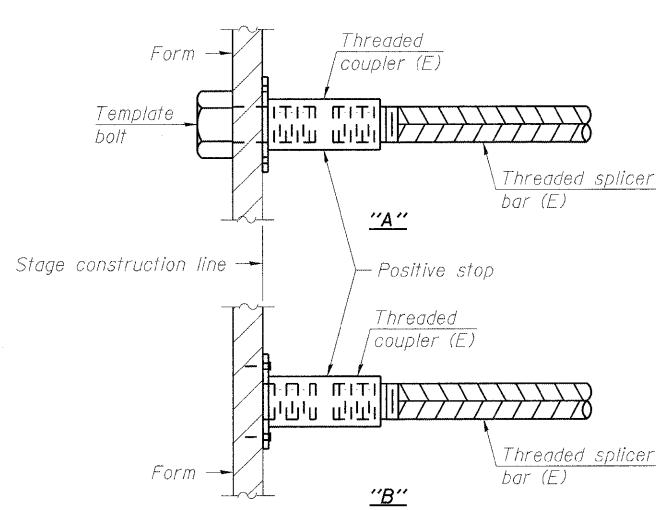

INSTALLATION AND SETTING METHODS

- "A" : Set bar splicer assembly by means of a template bolt.
- "B" : Set bar splicer assembly by nailing to wood forms or cementing to steel forms.
- (E) : Indicates epoxy coating.

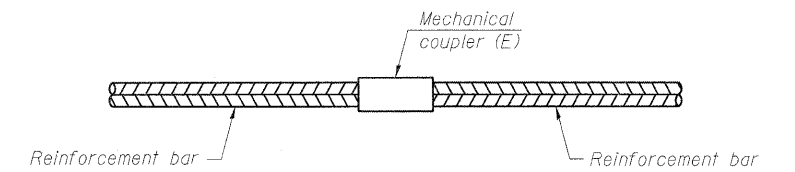

STANDARD MECHANICAL SPLICER

Location	Bar size	No. assemblies required

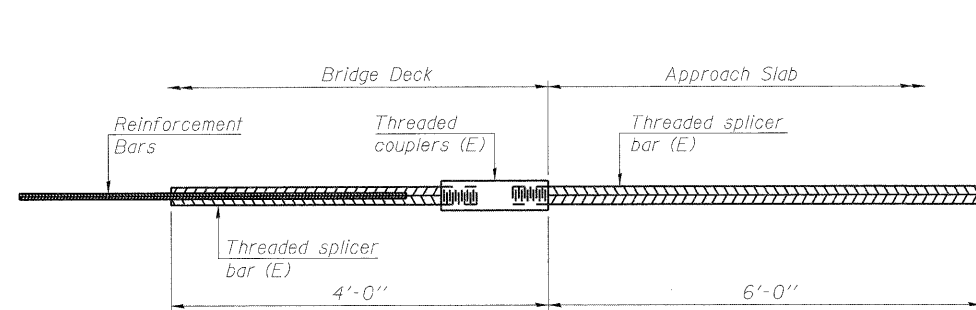

BAR SPLICER ASSEMBLY FOR #5 BAR ON INTEGRAL OR SEMI-INTEGRAL ABUTMENTS

No. required =

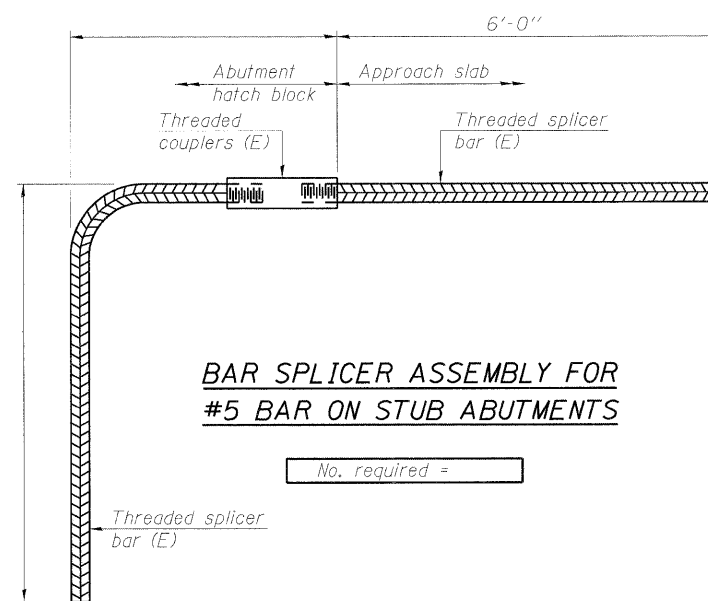

BAR SPLICER ASSEMBLY FOR #5 BAR ON STUB ABUTMENTS

No. required =

NOTES

- Splicer bars shall be deformed with threaded ends and have a minimum 60 ksi yield strength.
- All reinforcement shall be lapped and tied to the splicer bars.
- Bar splicer assemblies shall be epoxy coated according to the requirements for reinforcement bars. See Section 508 of the Standard Specifications.
- See special provision for Mechanical Splicers.
- See approved list of bar splicer assemblies and mechanical splicers for alternatives.

FILE NAME = G:\p\proj\2102155_0005\CAD\Structure\0160267_62L\55_005_Bar_Splicer.dgn

BSD-1

7-1-10



USER NAME = 2aajerb
 PLOT SCALE = N/A
 PLOT DATE = 3/1/2011

DESIGNED - BHS
 CHECKED - GSP
 DRAWN - MJB
 CHECKED - CSP

REVISED -
 REVISED -
 REVISED -
 REVISED -

STATE OF ILLINOIS
 DEPARTMENT OF TRANSPORTATION

BAR SPLICER ASSEMBLY AND MECHANICAL SPLICER DETAILS
 S.N. 016-0367

SHEET NO. 55 OF 6 SHEETS

F.A.P. RTE.	SECTION	COUNTY	TOTAL SHEETS	SHEET NO.
0341	2010-070-1	COOK	18	11
CONTRACT NO. 60L55			ILLINOIS FED. AID PROJECT	