

FAP ROUTE	SECTION	COUNTY	TOTAL SHEETS	SHEET NO.
586	60R-2, 37R-1	MADISON	502	250
STA.	TO STA.			
CONTRACT #16301				

PLAN	REVISIONS	DATE
NO.	BY	
	DATE	
	BY	
	DATE	
	BY	
	DATE	
	BY	
	DATE	

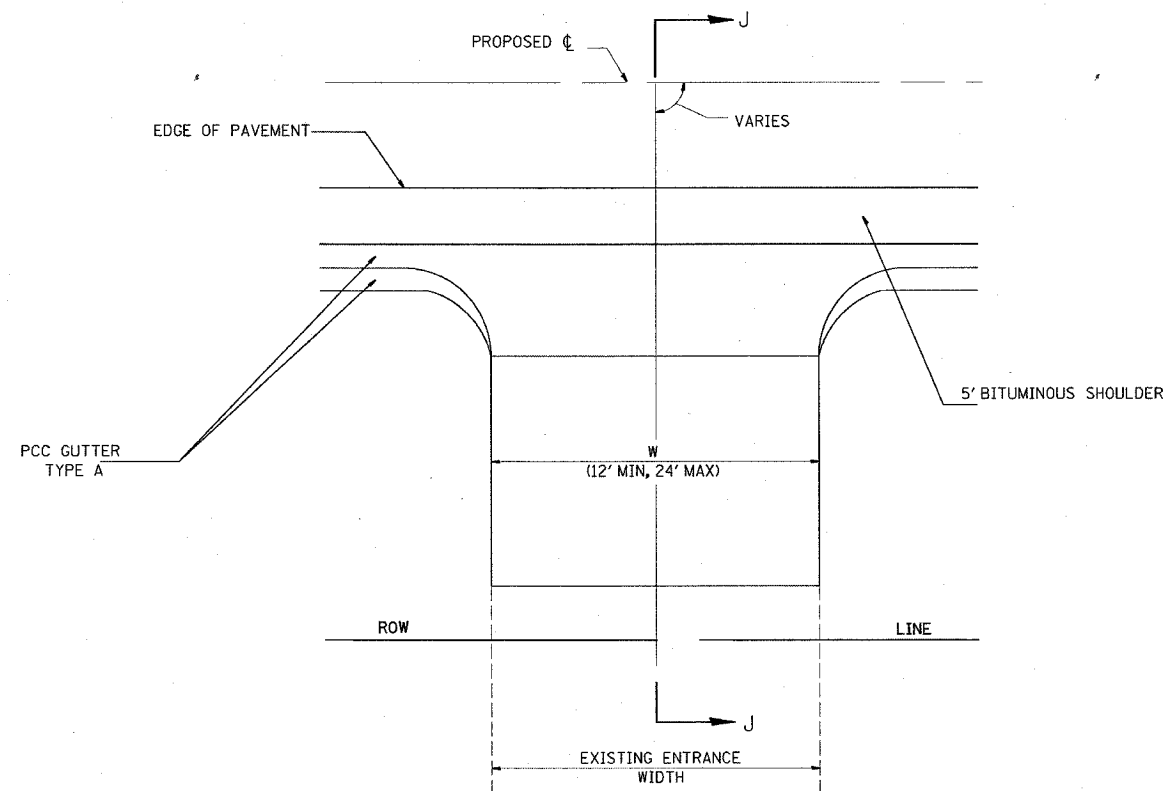

PE & FE DETAIL J
FIELD & PRIVATE ENTRANCE ADJACENT TO 8" BITUMINOUS SHOULDER AND PCC GUTTER TYPE A

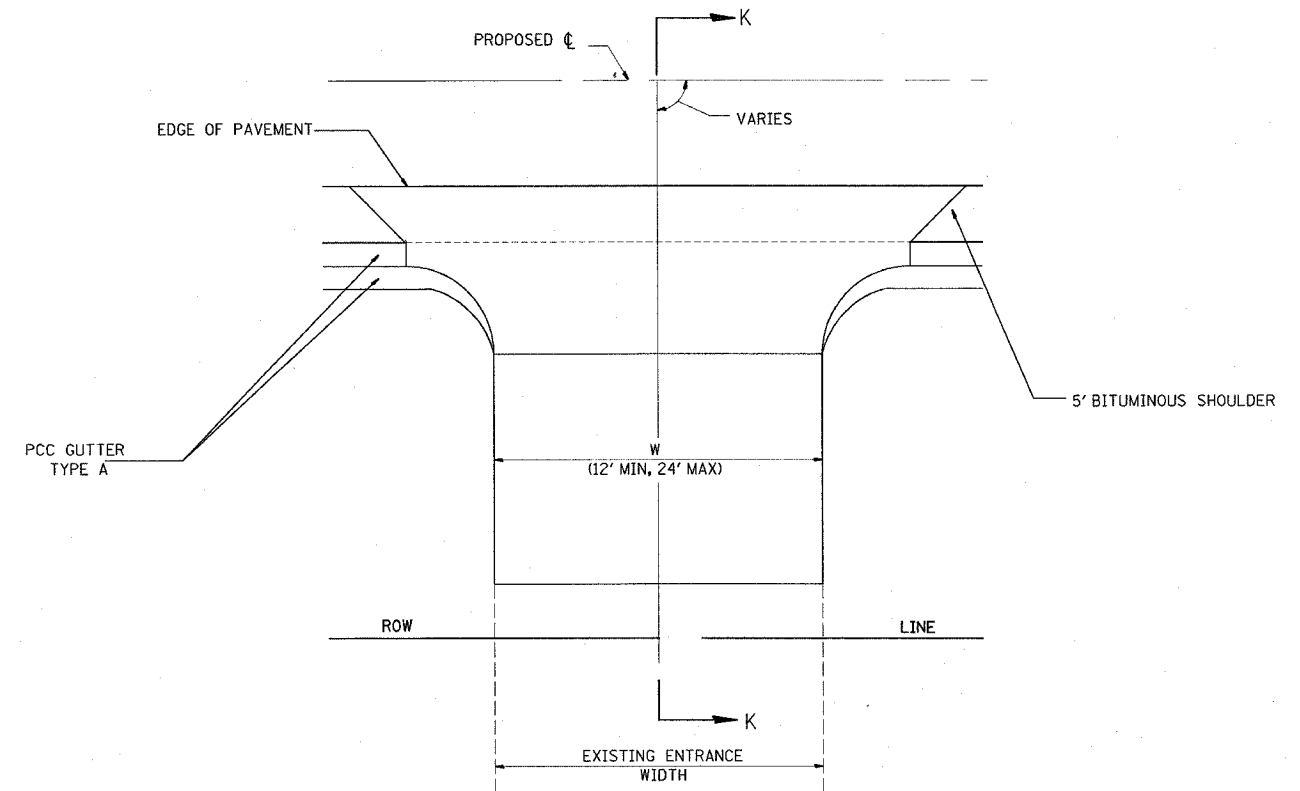

CE & SR DETAIL K
COMMERCIAL & SIDE ROAD ENTRANCE ADJACENT TO BITUMINOUS SHOULDER AND PCC GUTTER TYPE A

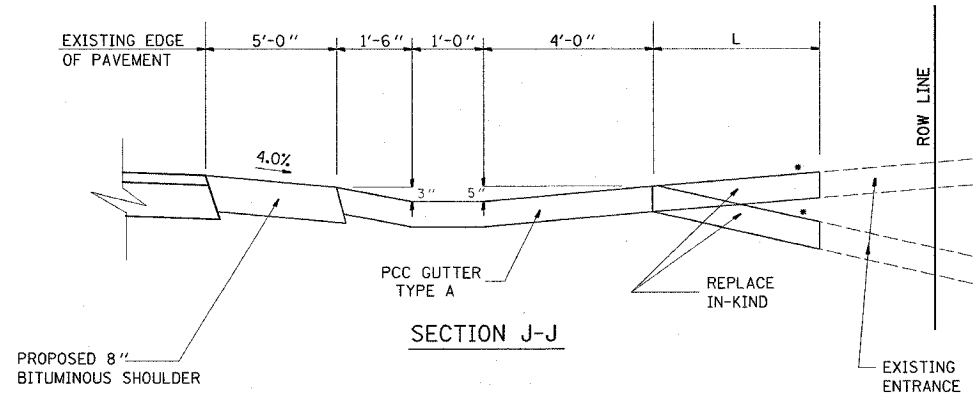

SEE CROSS SECTIONS FOR SLOPE
SEE PLANS FOR EXISTING SURFACE TYPE

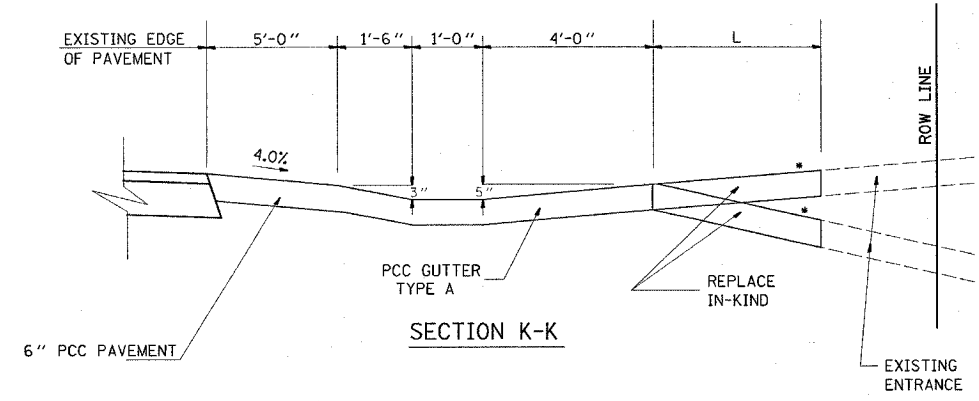

SEE CROSS SECTIONS FOR SLOPE
SEE PLANS FOR EXISTING SURFACE TYPE

TYPE OF ENTRANCE	EXISTING MATERIAL	NEW ENTRANCE MATERIAL (BEYOND RADIUS RETURNS OR TAPERS)				
		PCC DRIVEWAY PAVEMENT (6")	PCC DRIVEWAY PAVEMENT (8")	INCIDENTAL BITUMINOUS CONC SURFACING (3")	AGGREGATE BASE COURSE TYPE B (8")	AGGREGATE SURFACE COURSE TYPE B (6")
PE & FE	CONCRETE	X				
	BITUMINOUS AGGREGATE			X	X	X
CE & SR	CONCRETE		X			
	BITUMINOUS AGGREGATE			X	X	X

"L" - SEE SCHEDULE
"W" - SEE SCHEDULE

REVISIONS	
NAME	DATE

ILLINOIS DEPARTMENT OF TRANSPORTATION
ENTRANCE DETAILS

FAP ROUTE 586
SECTION 60R-2, 37R-1
MADISON COUNTY

DRAWN BY:
PLOT DATE: Friday July 02, 2004 @ 10:21:15 AM