

NOTE
Number of h bars in top slab includes two extra bars as shown

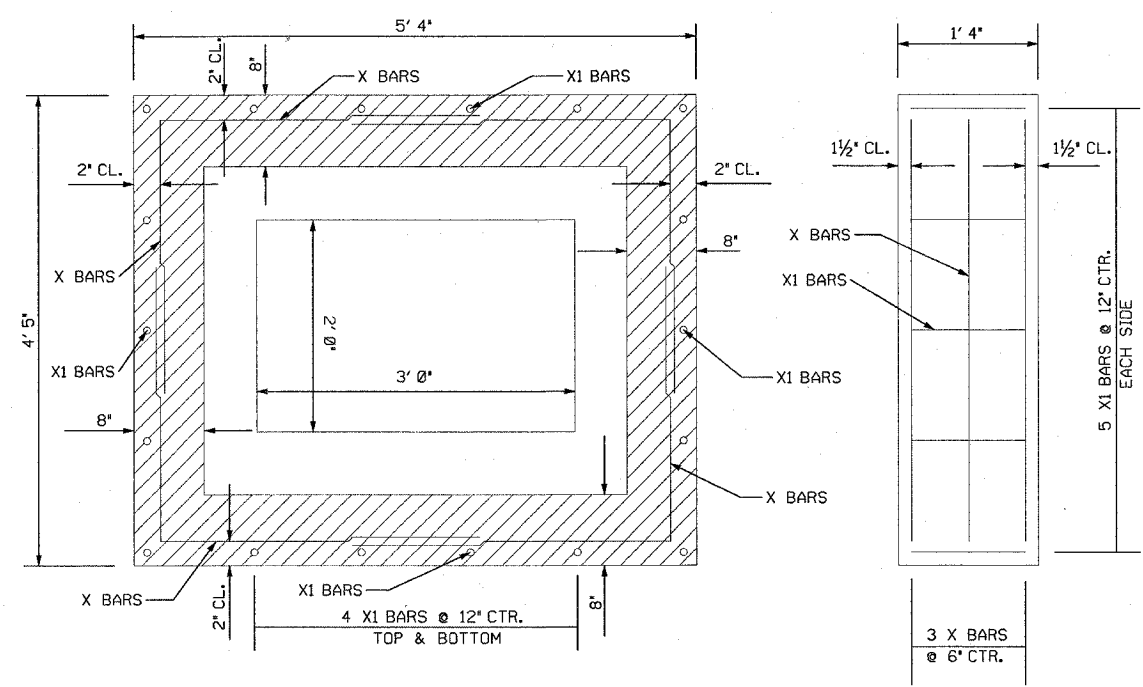

PRECAST TO CAST IN PLACE
CONNECTION COLLAR

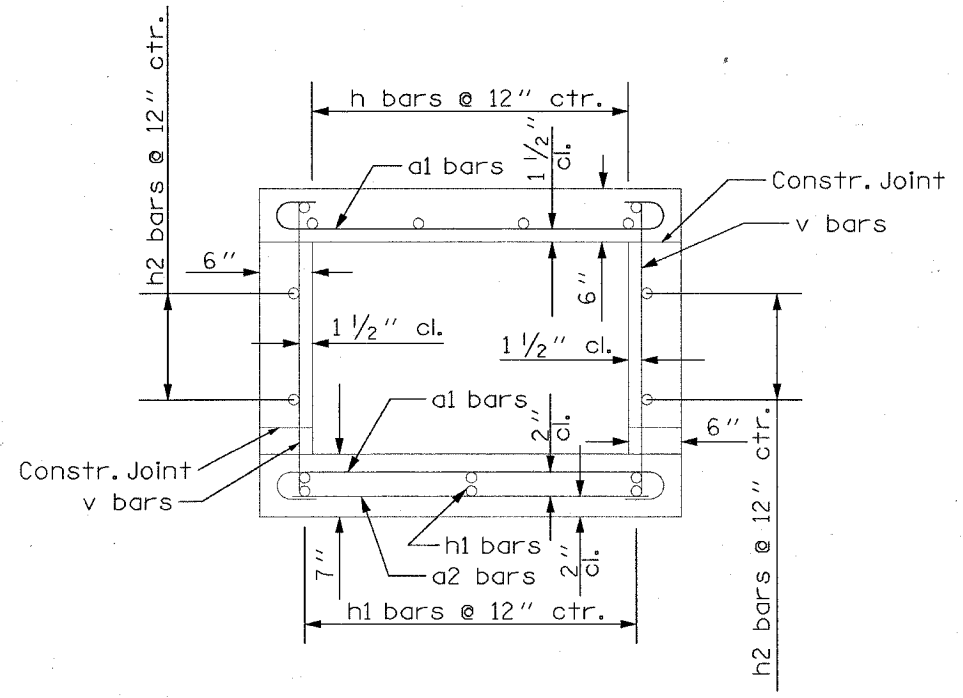
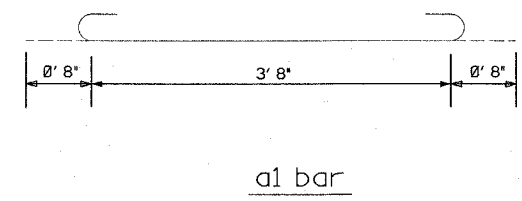
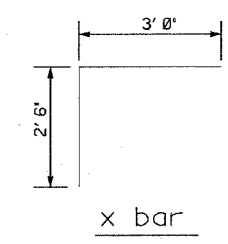
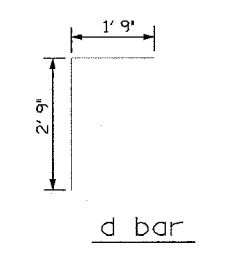
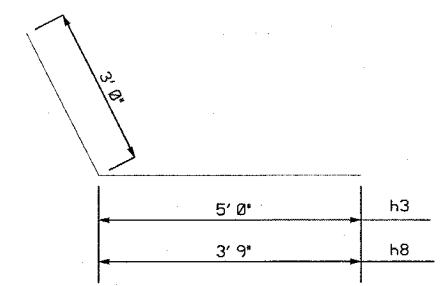
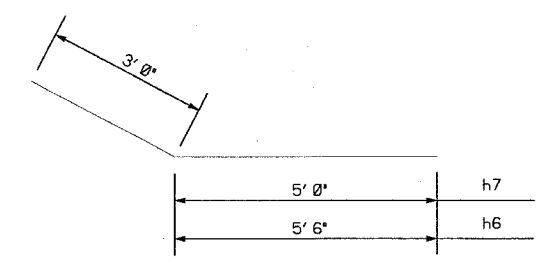
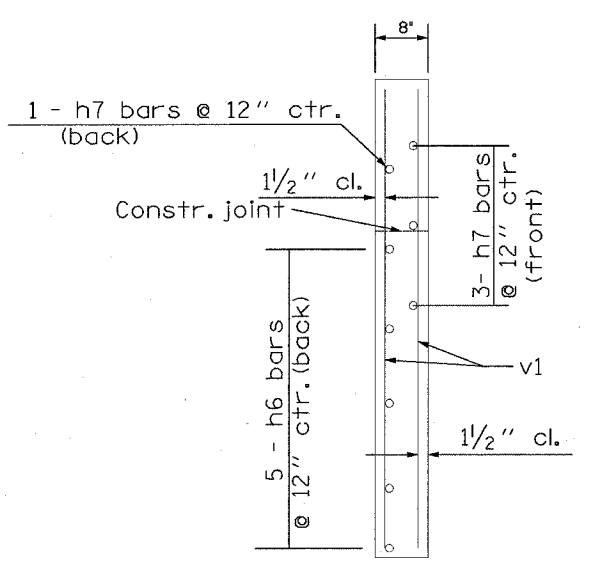

BILL OF MATERIAL				
Type	No.	Size	Length	Lbs
a1	44	#4	5' 0"	147.0
a2	10	#4	3' 4"	22.3
h	10	#4	8' 3"	55.1
h1	16	#4	8' 3"	88.2
h2	8	#4	7' 3"	38.7
d	5	#4	4' 6"	15.0
h3	16	#4	8' 0"	85.5
h4	6	#4	6' 11"	27.7
h6	20	#4	8' 6"	113.6
h7	16	#4	8' 0"	85.5
h8	20	#4	6' 9"	90.2
v	56	#4	2' 9"	102.9
v1	16	#4	5' 0"	53.4
x	12	#4	5' 6"	44.1
x1	18	#4	1' 0"	12.0
CONCRETE	C.Y.			7.0
REINF. BARS	LBS.			927.8
CONC. COLLAR	EACH			2

REVISIONS	
NAME	DATE

ILLINOIS DEPARTMENT OF TRANSPORTATION
DETAIL
BOX CULVERT
STA 686+17
FAP ROUTE 586 (IL 162)
SECTION 60R-2, 3TR-1
MADISON COUNTY

DRAWN BY:

PLAN	DATE
BY	
CHECKED	
DATE	
NO.	
FILE NAME	
NO.	
FILE NAME	
NO.	
FILE NAME	