

| | | |
|-----------|-----------|------|
| PLAN | SUBMITTED | DATE |
| NOTE BOOK | PLotted | |
| | BY | |
| | CHECKED | |
| | DATE | |

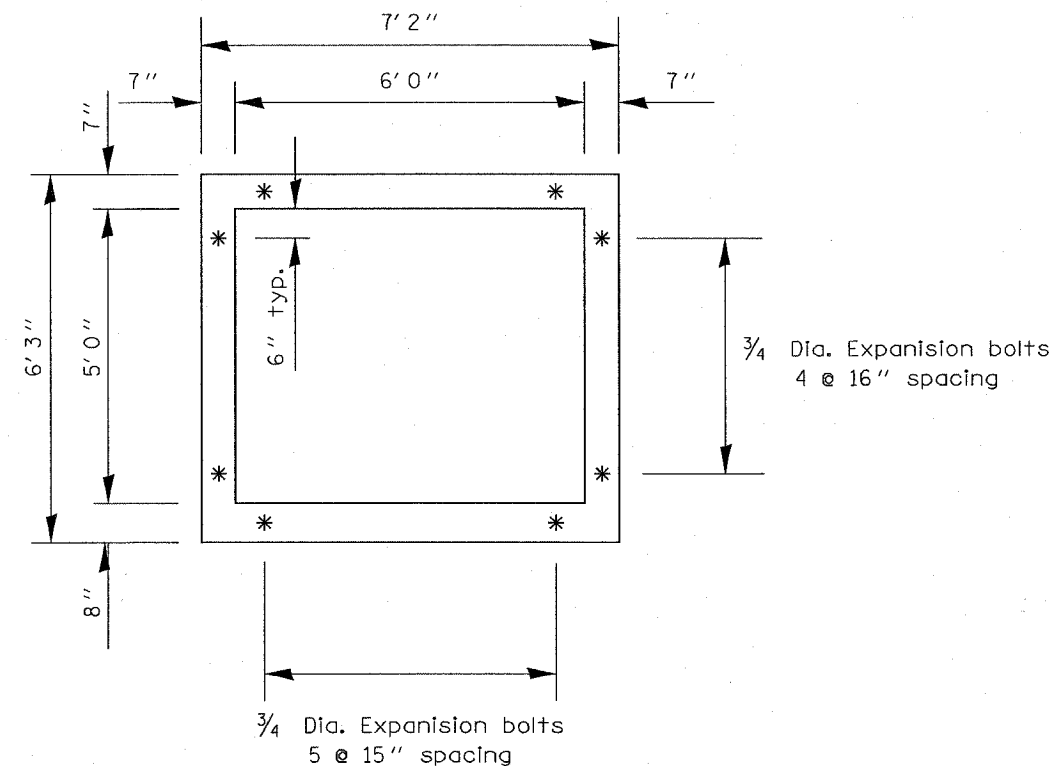
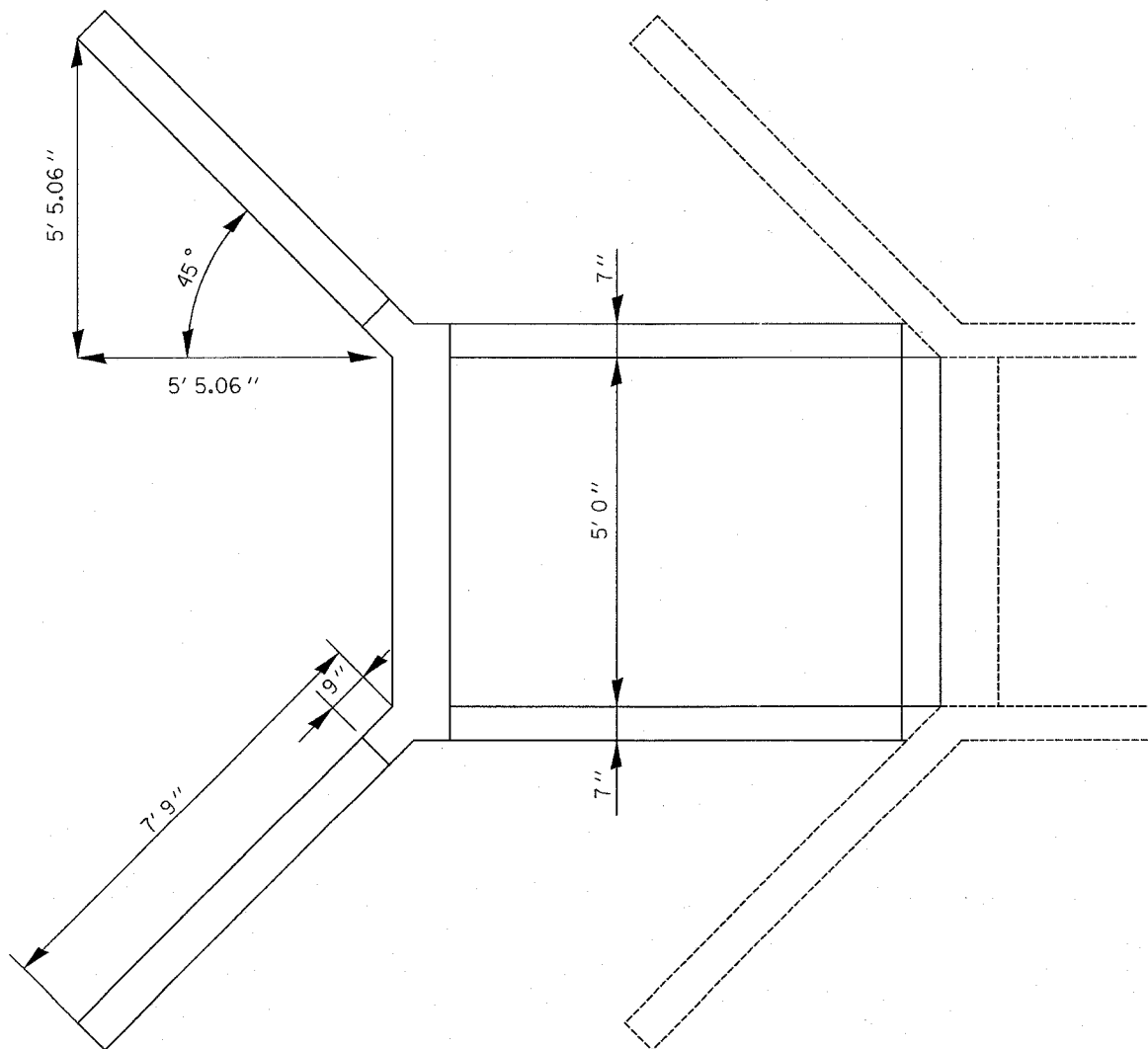
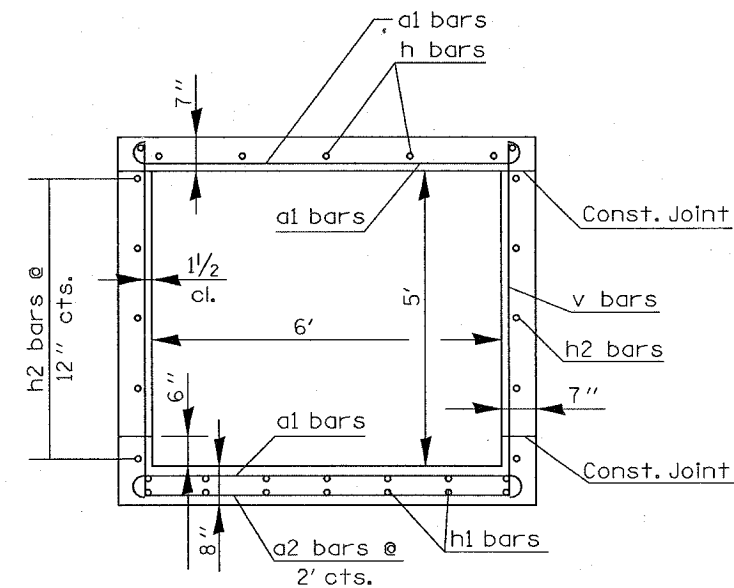
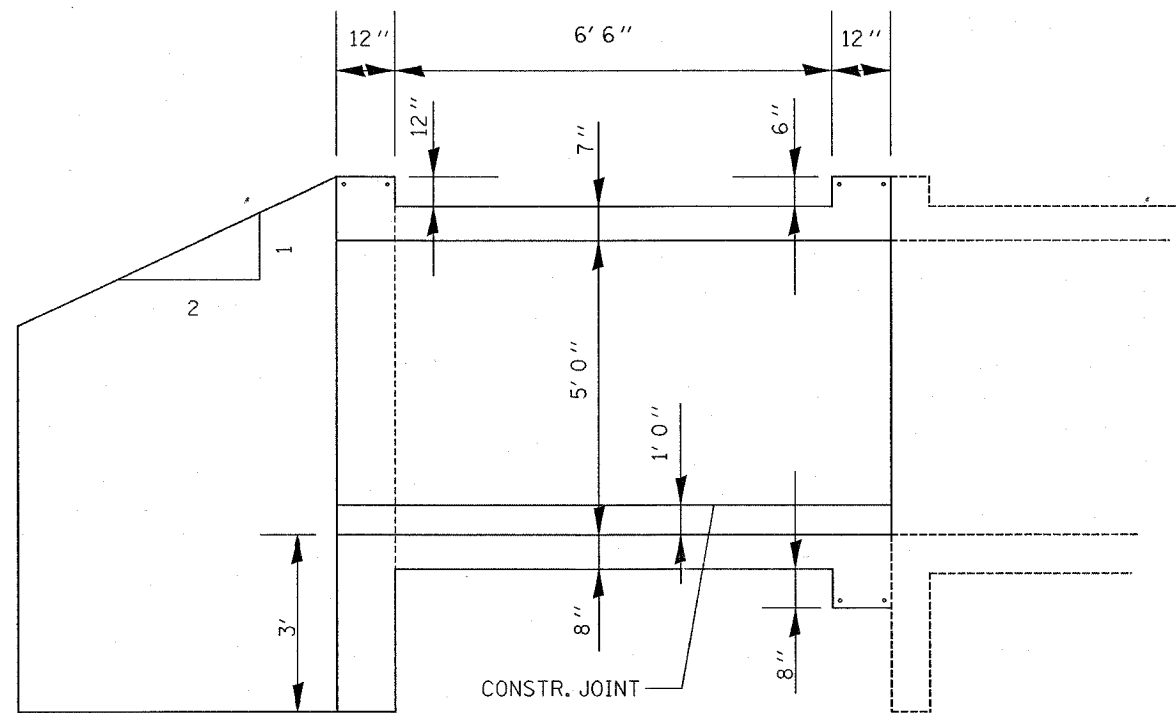

| BILL OF MATERIAL | | | |
|------------------|------|------|--------|
| a1 | 34 | #8 | 7' 10" |
| a2 | 5 | #4 | 6' 3" |
| h | 9 | #5 | 9' 3" |
| h1 | 14 | #4 | 9' 3" |
| h2 | 10 | #5 | 9' 3" |
| d | 6 | #4 | 4' 6" |
| v | 26 | #4 | 5' 11" |
| v1 | 8 | #4 | 8' 0" |
| h3 | 18 | #4 | 8' 3" |
| h8 | 16 | #4 | 11' 0" |
| h4 | 6 | #6 | 6' 11" |
| CONCRETE | C.Y. | 7.6 | |
| REINF. BARS | LBS. | 1446 | |
| EXPAN. BOLTS | EACH | 18 | |

| REVISIONS | |
|-----------|------|
| NAME | DATE |
| | |
| | |
| | |
| | |
| | |

ILLINOIS DEPARTMENT OF TRANSPORTATION

BOX CULVERT
 STA 635+60.46
 FAP ROUTE 586 (IL 162)
 SECTION 60R-2, 37R-1
 MADISON COUNTY

DRAWN BY: