

FAP ROUTE	SECTION	COUNTY	TOTAL SHEETS	SHEET NO
586	60R-2, 37R-1	MADISON	502	22
STA. TO STA.		CONTRACT NO: 76301		

IL 162 (MARKET ST)  
 HICKORY ST TO DEWEY ST  
 STA 591+05.78 TO STA 604+45.43

EXISTING

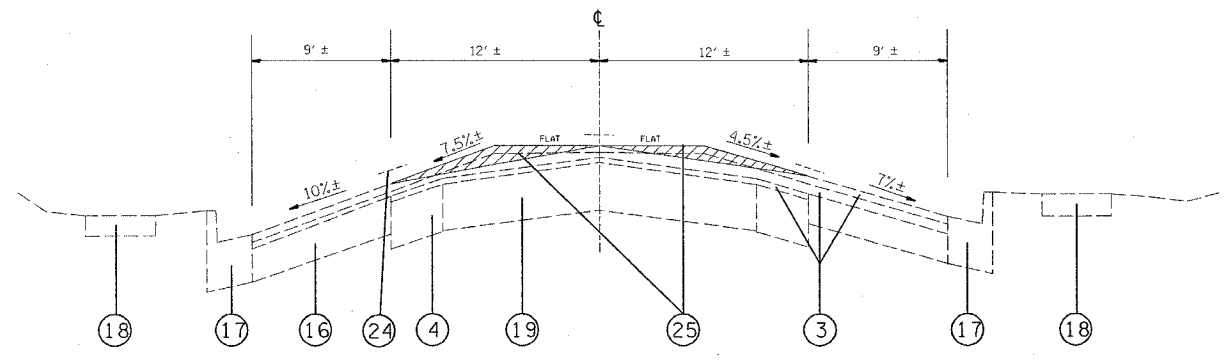

PROPOSED

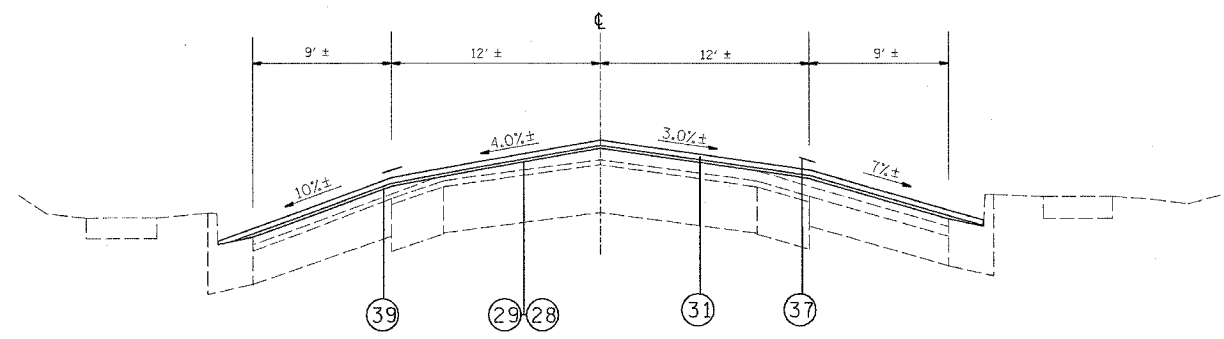

LEGEND

- ① EXIST PCC PAVEMENT (9"-7"-9")
- ② EXIST BINDER COURSE, 2 1/4"
- ③ EXIST BITUMINOUS RESURFACING (VARIES)
- ④ EXIST BITUMINOUS WIDENING, 9"
- ⑤ EXIST JOINTED REINFORCED PCC PAVEMENT, 12 1/4"
- ⑥ EXIST SUB-BASE
- ⑦ EXIST CONCRETE MEDIAN TYPE SB-6.12 (TBR)
- ⑧ EXIST PIPE UNDERDRAINS, 4" (TBR)
- ⑨ EXIST BITUMINOUS SHOULDER 12 1/4" (TBR)
- ⑩ EXIST BITUMINOUS SHOULDER, 6" (TBR)
- ⑪ EXIST AGG SHOULDER, TYPE B WEDGE (TBR)
- ⑫ EXIST BITUMINOUS BASE COURSE, 12 1/2"
- ⑬ EXIST BITUMINOUS BASE COURSE, 10 1/2"
- ⑭ EXIST AGGREGATE SHOULDER, 6" (TBR)
- ⑮ EXIST BITUMINOUS CONCRETE BINDER COURSE, 1 3/4"
- ⑯ EXIST BAM BASE COURSE, 6"
- ⑰ EXIST CURB AND/OR CURB AND GUTTER
- ⑱ EXIST SIDEWALK
- ⑲ EXIST CONCRETE BASE COURSE
- ⑳ EXIST CONCRETE CURB
- ㉑ EXIST CONCRETE GUTTER, TYPE A
- ㉒ EXIST 2 1/2" BRICK SURFACE
- ㉓ EXIST MASTIC CUSHION
- ㉔ EXIST PAVEMENT MARKING
- ㉕ PROP BITUMINOUS SURFACE REMOVAL (VAR DEPTH)
- ㉖ PROP BITUMINOUS SURFACE REMOVAL (1")
- ㉗ PROP BITUMINOUS SURFACE REMOVAL (1 1/2")
- ㉘ PROP PCC BASE COURSE, 12 1/4"
- ㉙ PROP BITUMINOUS BINDER COURSE SUPERPAVE, IL 19.0, N90, 1 1/2"
- ㉚ PROP BITUMINOUS MATERIALS (PRIME COAT)
- ㉛ PROP AGGREGATE (PRIME COAT)
- ㉜ PROP LEVELING BINDER (MM), SUPERPAVE N90, 1"
- ㉝ PROP POLYMERIZED BIT SURFACE COURSE, SUPERPAVE, MIX E, N90, 1 1/2"
- ㉞ PROP CONCRETE MEDIAN SURFACE, 4"
- ㉟ PROP COMB CONCRETE CURB AND GUTTER, TYPE B-6.24
- ㊱ PROP COMB CONCRETE CURB AND GUTTER, TYPE B-6.12
- ㊲ PROP COMB CONCRETE CURB AND GUTTER, TYPE M-6.06
- ㊳ PROP COMB CONCRETE CURB AND GUTTER, TYPE M-6.24
- ㊴ PROP THERMOPLASTIC PAVEMENT MARKING
- ㊵ PROP STORM SEWER
- ㊶ PROP LEVELING BINDER (MM), SUPERPAVE N70, 3/4"
- ㊷ PROP POLYMERIZED BIT SURFACE COURSE, SUPERPAVE, MIX E, N70, 1 1/2"
- ㊸ PROP BITUMINOUS SHOULDER, 8"
- ㊹ PROP AGGREGATE SHOULDER TYPE A
- ㊺ PROP GUTTER, TYPE A
- ㊻ PROP PCC SIDEWALK, 4"
- ㊼ PROP PCC PAVEMENT, 8"
- ㊽ PROP STRIP REFLECTIVE CRACK CONTROL
- ㊾ PROP TIE BAR

MILLING PROCEDURES: UTILIZE THE CENTERLINE FOR THE CONTROL POINT. MILL AT A ZERO DEPTH FROM THE CENTERLINE TO THE EDGE OF PAVEMENT. THIS SHOULD CREATE A 4% SLOPE ON THE LEFT AND A 3% SLOPE ON THE RIGHT. NO MILLING WILL BE DONE ON THE PARKING LANES. THIS WORK WILL BE PAID FOR AS (BITUMINOUS SURFACE REMOVAL (VARIABLE DEPTH)).

PLAN	DATE
BY	
REVISIONS	
NO.	
DESCRIPTION	

7/2/2004 02:28:04 7:22:39 AM  
 c:\pwworkspace\76301\1\165596.plt\165596.dgn L:\1-63

REVISIONS	
NAME	DATE

ILLINOIS DEPARTMENT OF TRANSPORTATION  
**TYPICAL SECTIONS**  
 FAP ROUTE 586 (IL 162)  
 SECTION 60R-2,37R-1  
 MADISON COUNTY  
 DRAWN BY: