

CABLE TO GROUND ROD

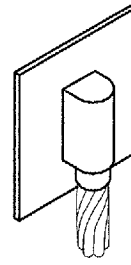

CABLE TO SURFACE

DETAIL NOTES

- EXOTHERMIC WELDS SHALL BE CADWELD AS MANUFACTURED BY ERICO PRODUCTS, SOLON, OHIO, ULTRAWELD AS MANUFACTURED BY HARGER LIGHTNING PROTECTION & GROUNDING EQUIPMENT, GRAYSLAKE, IL, OR THERMOWELD AS MANUFACTURED BY CONTINENTAL INDUSTRIES, TULSA, OKLAHOMA. VERIFY PROPER SIZES, MOLDS, TYPES, AND REQUIREMENTS FOR THE RESPECTIVE APPLICATION WITH THE MANUFACTURER, AND INSTALL PER THEIR DIRECTIONS.
- FOR APPLICATIONS TO GALVANIZED STEEL OR PAINTED STEEL, REMOVE GALVANIZING AND/OR PAINT & CLEAN THE SURFACE TO EXPOSE BARE STEEL BEFORE MAKING EXOTHERMIC WELD CONNECTION.
- VERIFY EXOTHERMIC MOLDS ARE SUITABLE FOR USE WITH THE RESPECTIVE TYPE (SOLID OR STRANDED) & SIZE CONDUCTOR.

EXOTHERMIC WELD DETAILS

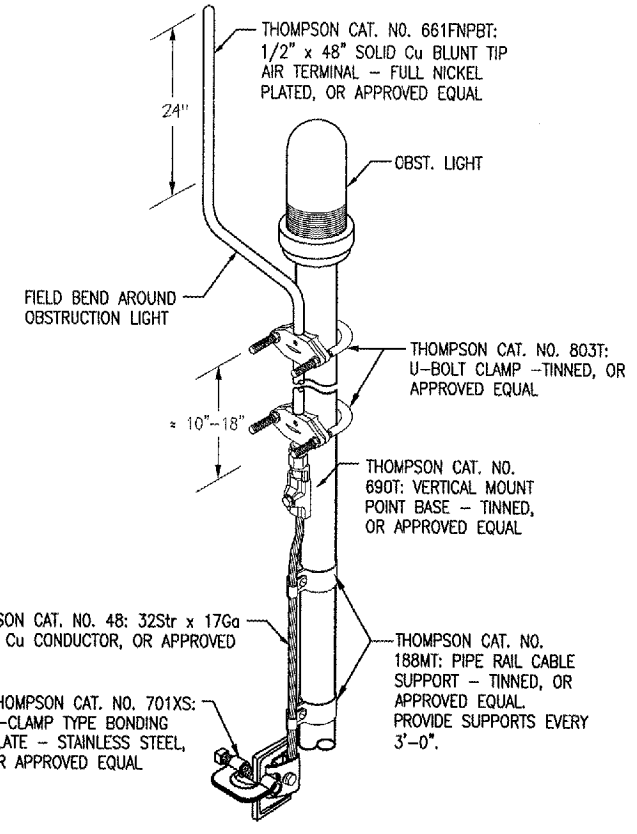

DETAIL A  
NTS

NOTES

- REFERENCES TO THOMPSON ARE THOMPSON LIGHTNING PROTECTION INC., 901 SIBLEY MEMORIAL HWY, ST. PAUL, MN 55188, PHONE: 651-455-7661, 800-777-1230, FAX: 651-455-2545.
- VERIFY LIGHTNING PROTECTION COMPONENTS AND CATALOG NUMBERS WITH THE RESPECTIVE LIGHTNING PROTECTION EQUIPMENT MANUFACTURER.

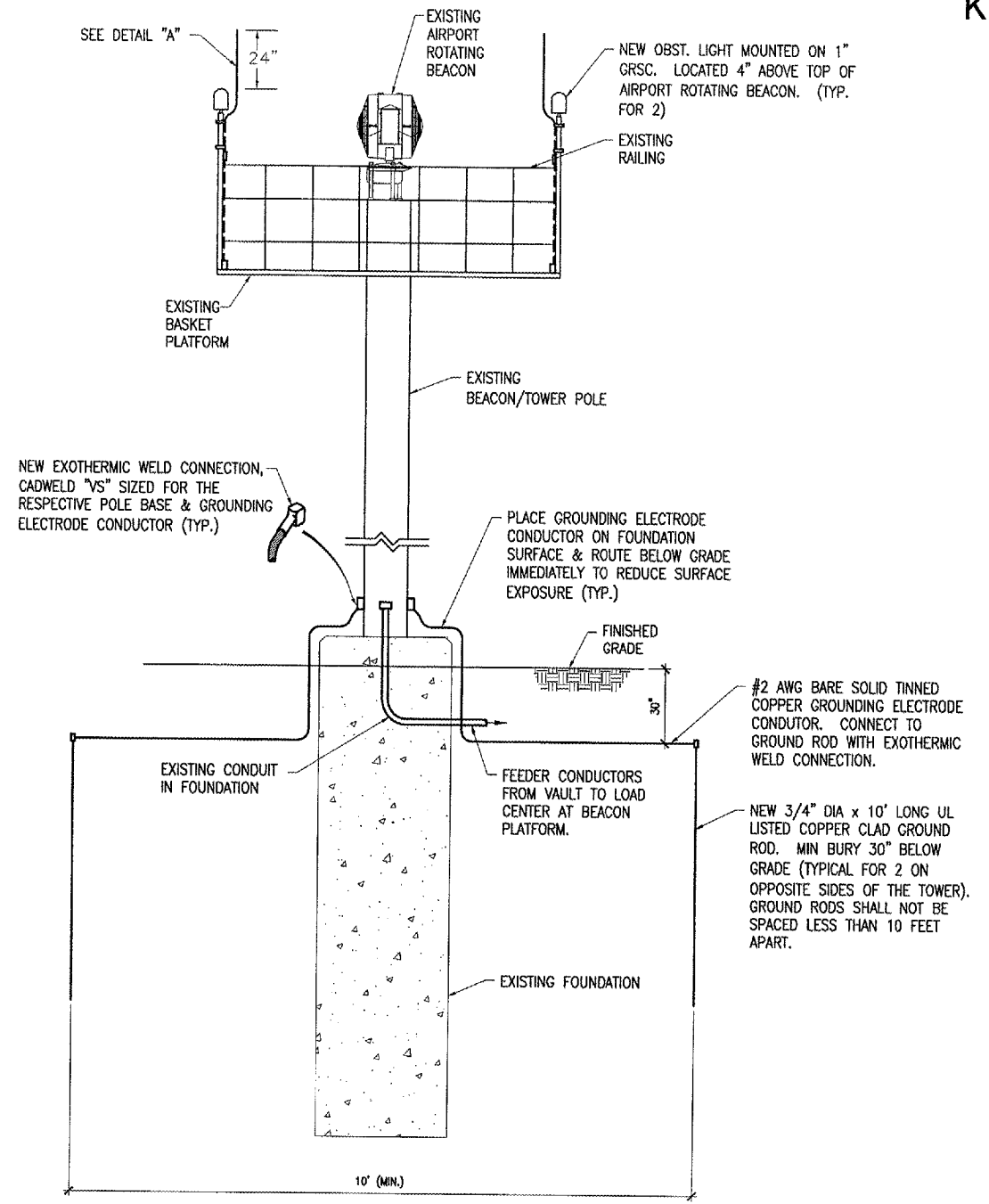

LIGHTNING PROTECTION DETAIL FOR AIRPORT ROTATING BEACON  
NTS

AIRPORT ROTATING BEACON PANEL			
CKT #	DUTY	SIZE	CKT #
1	AIRPORT ROTATING BEACON	15A 1P	2
3	OBSTRUCTION LIGHTS	15A 1P	4
5	BLANK		6
7	GFCI RECEPTACLE	20A 1P	8
9	BLANK		10
11	BLANK		12

125 AMP, 120/240 VAC, 1 PHASE, 3 WIRE, 12 CIRCUIT LOAD CENTER WITH CONVERTIBLE MAIN LUGS IN A NEMA 3R RAIN PROOF ENCLOSURE, SQUARE D CAT. NO. Q0112L125GRB OR APPROVED EQUAL.

NOTES

- INCLUDE EQUIPT GROUND BAR KIT.
- ALL BREAKERS SHALL HAVE 10,000 AIC RATING AT 120/240 VAC.
- PHASE "A" SHALL BE SWITCHED THROUGH A LIGHTING CONTACTOR AT THE VAULT. PHASE "B" SHALL BE UNSWITCHED.
- INCLUDE ENGRAVED PHENOLIC LEGEND PLATE LABELED ARB PANEL, 120/240 VAC, 1PH, 3W, FED FROM VAULT.

NOTE: SEE SHEETS 38, 42, 43, & 46 FOR ADDITIONAL INFORMATION REGARDING WIRING FOR THE AIRPORT ROTATING BEACON CIRCUIT.

ALL WORK SHOWN ON THIS SHEET SHALL BE PAID FOR UNDER ITEM AR800591 - UPGRADE AIRPORT ROTATING BEACON - PER L.S.

DATE	REVISION	BY

Kewanee Municipal Airport  
Kewanee, Henry County, Illinois  
A.I.P. PROJ.: 3-17-0058-810  
ILL. PROJ.: EZI-3533

Project No.	810-08TXD-0800
Revision	E-502.DWG
Scale	NONE
Date	04/22/05
LAYOUT	KNL 09/23/05
DRAWN	MV 09/27/05
REVIEWED	LDP 01/17/06

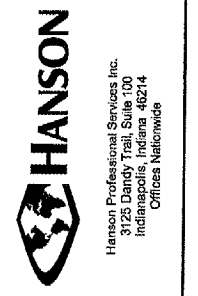

OVERLAY TXY & APRON CONSTRUCT VAULT LIGHTNING PROTECTION DETAILS FOR BEACON

JAN 18, 2006 8:17 AM DMV I:\AIRPORTS\KEWANEE\810-08TXD\AIRPORT\SHEETS\E-502.DWG -- Work-FLR