

F.A.S.	SECTION	COUNTY	TOTAL SHEETS	SHEET NO.
813	02-0087-00-RS	EDWARDS	4	2
FEB ROAD DIST. NO. 7		ILLINOIS	BONEGAP ROAD (NORTH)	

LEC JOB # HD41019ED  
CONTRACT NO. 95447

**TYPICAL CROSS SECTION EXISTING**

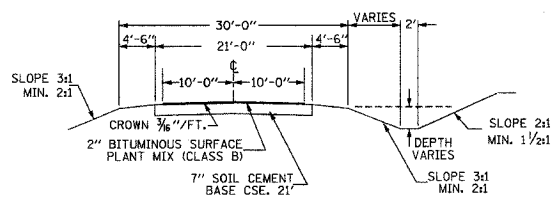

**TYPICAL CROSS SECTION PROPOSED**

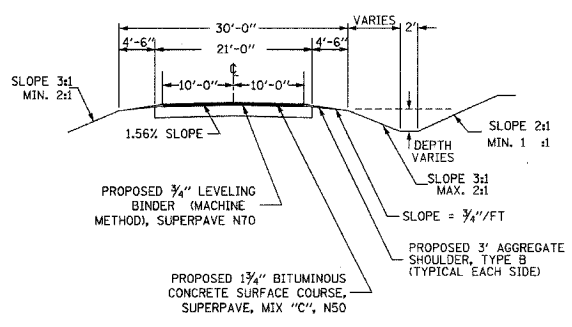

**GENERAL NOTES:**

THIS SECTION CONSISTS OF PAVEMENT REMOVAL AND REPLACEMENT SPECIAL, LEVELING BINDER (MACHINE METHOD), SUPERPAVE N70, AND BITUMINOUS CONCRETE SURFACE COURSE, SUPERPAVE, MIX "C", N50, AGGREGATE SHOULDERS, AND OTHER MISCELLANEOUS ITEMS NECESSARY TO COMPLETE THE PROJECT, ALL IN ACCORDANCE WITH THE PLANS, SPECIAL PROVISIONS AND "STANDARD SPECIFICATIONS FOR ROAD AND BRIDGE CONSTRUCTION" ADOPTED JANUARY 1, 2002.

THE EXISTING GRADE, ALIGNMENT, DRAINAGE STRUCTURES, BASE AND SURFACE WERE CONSTRUCTED UNDER SECTIONS 26-G AND 26-Q AND SHALL REMAIN IN PLACE. ALL STATIONS REFERRED TO IN THE PLANS AND PROPOSAL ARE REFERENCED TO THE ABOVE MENTIONED SECTIONS.

MAXIMUM PERCENT OF GRADE	-4.00 %
MINIMUM STOPPING SIGHT DISTANCE	525 FT
DESIGN SPEED	50 MPH
CURRENT ADT	500 VPD
DESIGN ADT (20 YEAR)	600 VPD

THE BITUMINOUS CONCRETE SURFACE COURSE, SUPERPAVE, MIX "C", N50 SHALL BE PLACED IN ONE LIFT WITH A MINIMUM THICKNESS OF 1 1/4".

THE QUANTITY SHOWN IN THE SUMMARY OF QUANTITIES FOR BITUMINOUS CONCRETE SURFACE COURSE, SUPERPAVE, MIX "C", N50 ALLOWS 108.9 TON FOR THE INTERSECTIONS, SIDEROADS, AND END TAPERS; 73.8 TON FOR THE ENTRANCES; 10.8 TON FOR THE MAILBOX TURNOUTS, AND 3461.9 TON FOR THE 1 1/4" BITUMINOUS CONCRETE SURFACE COURSE, SUPERPAVE, MIX "C", N50.

THE QUANTITY SHOWN IN THE SUMMARY OF QUANTITIES FOR LEVELING BINDER (MACHINE METHOD), SUPERPAVE N70 ALLOWS 558 TON FOR CROWN CORRECTION AND 1484 TON FOR THE 3/4" LEVELING BINDER (MACHINE METHOD), SUPERPAVE N70.

A BITUMINOUS TAPER OF 0" TO 2 1/2" SHALL BE CONSTRUCTED FROM STATION 0+00 TO STATION 0+50 AND 2 1/2" TO 0" FROM STATION 159+50 TO STATION 160+00.

THE FOLLOWING RATES HAVE BEEN USED TO CALCULATE PLAN QUANTITIES:

AGGREGATE SHOULDERS TY. B	1.8 T / CU YD
BITUMINOUS CONCRETE	0.0560 T / SQ YD * INCH
AGGREGATE PRIME COAT	0.001 T / SQ YD
BITUMINOUS MATERIAL (PRIME COAT)	0.05 GAL / SQ YD

**SUMMARY OF QUANTITIES**

QUANTITY	UNIT	ITEM	1000 CODE NUMBER
1600.00	FOOT	SHORT-TERM PAVEMENT MARKING REMOVAL	XX003140
75.00	TON	PAVEMENT REMOVAL AND REPLACEMENT (SPECIAL)	XX127400
3655.00	TON	BITUMINOUS CONCRETE SURFACE COURSE, SUPERPAVE, MIX "C", N50	X4066414
2042.00	TON	LEVELING BINDER (MACHINE METHOD), SUPERPAVE N70	X4066770
2142.00	GALLON	BITUMINOUS MATERIALS (PRIME COAT)	40600100
43.00	TON	AGGREGATE (PRIME COAT)	40600300
1153.00	TON	AGGREGATE SHOULDERS, TYPE B	48101200
1.00	L SUM	MOBILIZATION	67100100
1.00	L SUM	TRAFFIC CONTROL AND PROTECTION, STANDARD 701306	70100460
1.00	L SUM	TRAFFIC CONTROL AND PROTECTION, STANDARD 701336	70100600
3200.00	FOOT	SHORT-TERM PAVEMENT MARKING	70300100
37682.00	FOOT	PAINT PAVEMENT MARKING-LINE 4"	78001110 Δ
200.00	EACH	RAISED REFLECTIVE PAVEMENT MARKER	78100100 Δ

Δ SPECIALTY ITEMS

**DETAIL OF PRIVATE AND FIELD ENTRANCES**

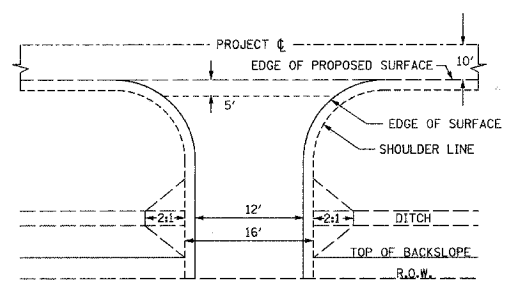

NOTE: THE 5' AREA FROM THE EDGE OF SURFACE, AS SHOWN ABOVE, SHALL BE BITUMINOUS CONCRETE SURFACE COURSE, SUPERPAVE, MIX "C", N50 FOR THE PRIVATE ENTRANCES AND THE FIELD ENTRANCES. THIS QUANTITY IS INCLUDED IN THE QUANTITY FOR BITUMINOUS CONCRETE SURFACE COURSE, SUPERPAVE, MIX "C", N50.

**PRIVATE & FIELD ENTRANCE APPROACH DETAIL**

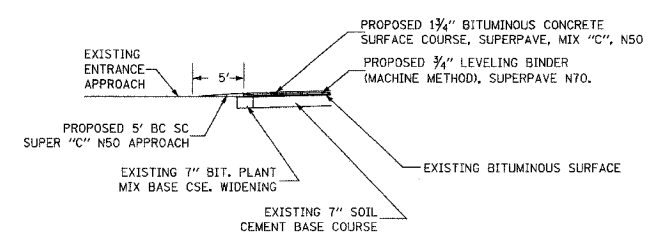

**DETAIL OF PAVEMENT REMOVAL AND REPLACEMENT SPECIAL**

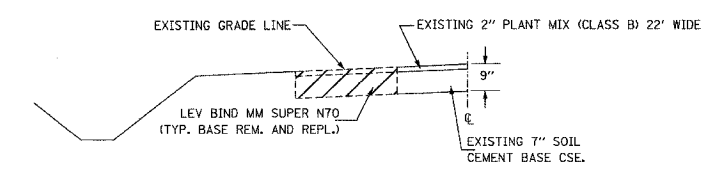

NOTE: IN THE TYPICAL DETAIL ABOVE THE DISTANCE FROM THE CENTERLINE LEFT OR RIGHT AND THE WIDTH OF PAVEMENT REMOVAL AND REPLACEMENT VARIES. SEE SCHEDULE OF PAVEMENT REMOVAL AND REPLACEMENT SPECIAL FOR PROPOSED LOCATIONS.

**AGGREGATE SHOULDER DETAIL**

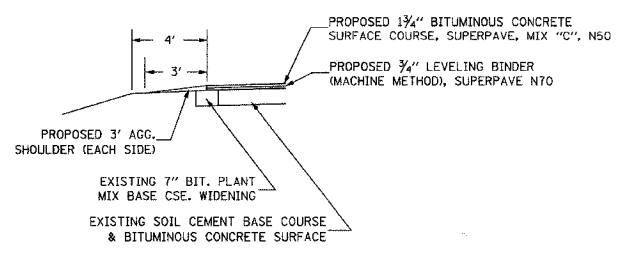

**UTILITIES**

J.L.L.E.  
800-892-0123

323 W. 3RD ST.  
P.O. BOX 160  
MT. CARMEL, IL  
62863  
PHONE:  
(618)-262-8651  
FAX:  
(618)-263-3327

405 W. STATE ST.  
SUITE 1  
PRINCETON, IN  
47670  
PHONE:  
(812)-386-7611  
FAX:  
(812)-386-2812



PROFESSIONAL DESIGN FIRM  
LAND SURVEY &  
PROFESSIONAL  
ENGINEERING  
CORPORATION

184-000887  
(62-02649)(36-002769)



MICHAEL L. GILLINGHAM  
DUSTIN K. BUNTING

NAME  
SIGNATURE  
DATE  
10-27-05  
11-30-05  
EXPIRES