

ROUTE NO.	SECTION	COUNTY	TOTAL SHEETS	SHEET NO.
FAU 6998	99-00209-02-PV	VERMILION	72	40
FED. ROAD DIST. NO.	ILLINOIS PROJECT			
CONTRACT NO. 91356				

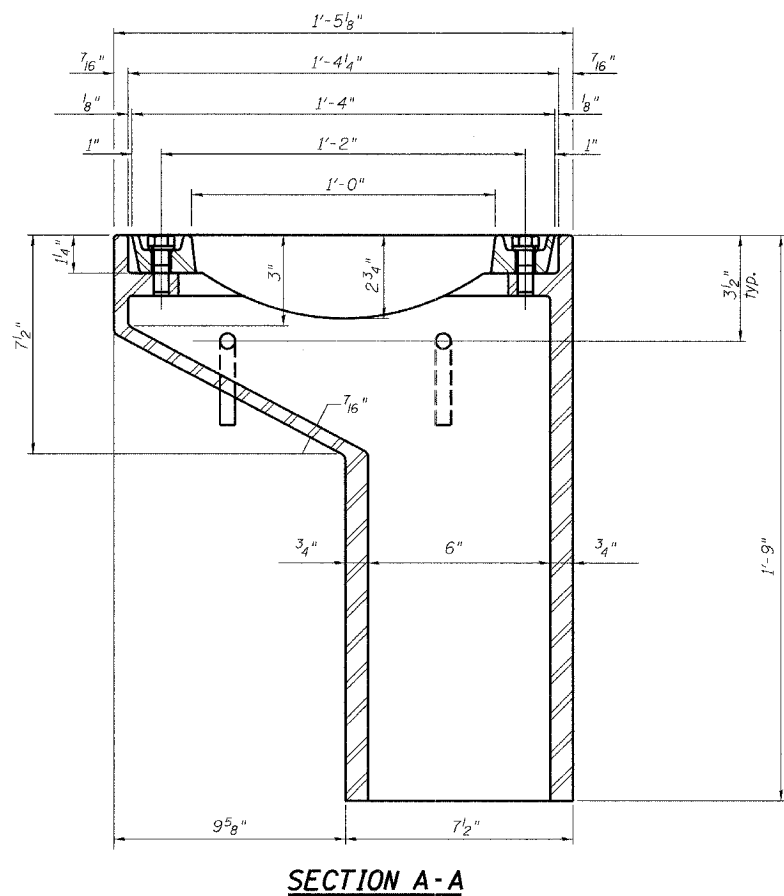

See sheets 7 & 8 of 21 for scupper location relative to parapet & barrier.

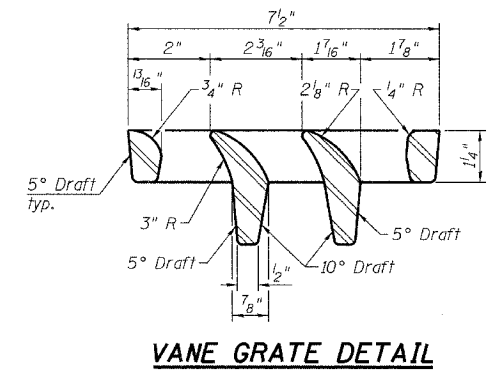
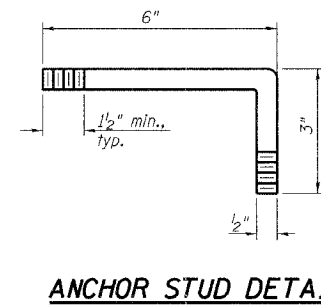
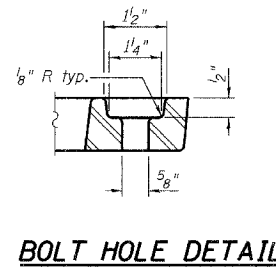
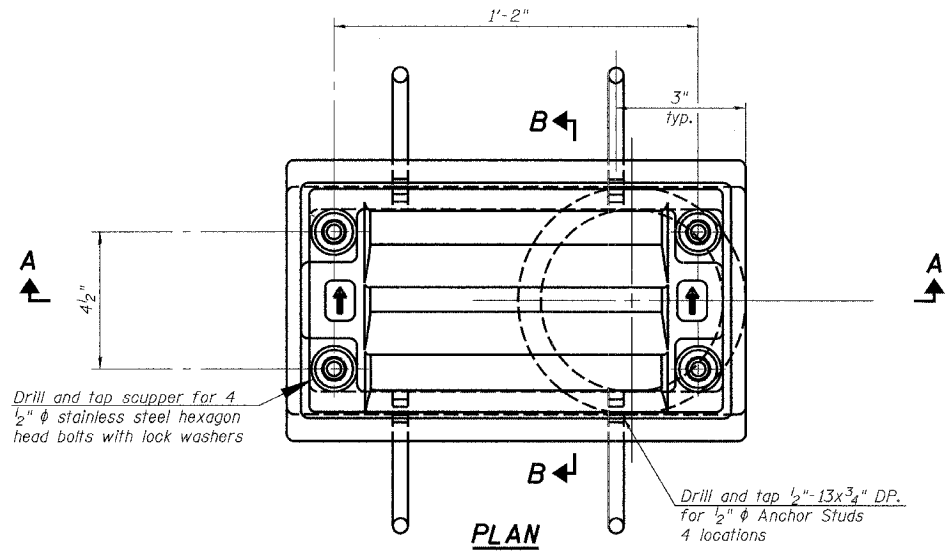
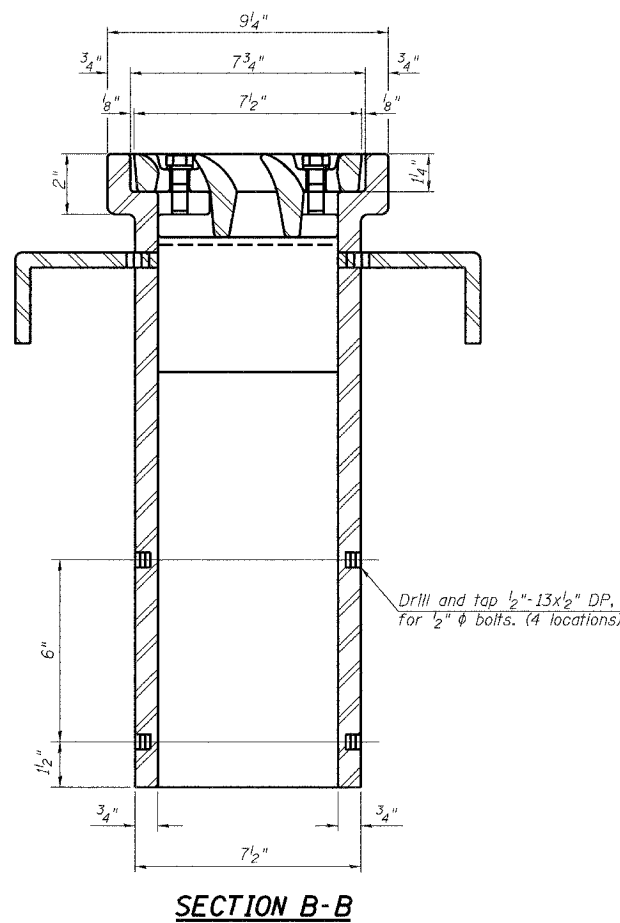

Notes: All cast iron parts shall be gray iron conforming to the requirements of AASHTO M 105, Class 35B. Bolts, anchor studs, washers and nuts shall conform to the requirements of ASTM A 307 and shall be galvanized according to AASHTO M 232. The grate, frame and downspout shall be galvanized according to AASHTO M 111 and ASTM A 385. Downspouts located on the exterior side of a painted steel fascia beam shall be painted with the finish coat specified for the exterior side of the fascia beam. As an alternate, bolts, anchor studs, washers and nuts may be stainless steel according to Article 1006.29(d) of the Standard Specifications. Structural steel weldments of equal sections and of the same configuration may be substituted for cast iron. Fillet or full penetration welds shall be used for the weldments. Details shall be submitted to the Engineer for approval. The Contractor shall take appropriate measures to assure that Protective Coat is not applied to the scupper. Cost of the Grate, Frame, Downspout, Anchor Studs, Bolts, Washers and Nuts including complete installation of the scupper shall be paid for at the contract unit price each for Drainage Scupper, DS-II.

BILL OF MATERIAL

ITEM	UNIT	QUANTITY
Drainage Scupper, DS-II	Each	2

DRAINAGE SCUPPER, DS-II

Date	Designed ACW	WINTER AVENUE OVER STONEY CREEK SECTION 99-00209-02-PV CITY OF DANVILLE, IL VERMILION COUNTY STA. 106+34.70 PROP. STR. NO. 092-6033	Sheet No.
Revisions	Drawn BKN		9
	Checked KWB		of 21
	Approved KWB		URS Job No.
Prepared by:	URS 3040 North University Avenue Decatur, IL 62526		36430866