

F.A.P. RTE.	SECTION	COUNTY	TOTAL SHEETS	SHEET NO.
308		WHITESIDE	47	5
STA.		TO STA.		
FED. ROAD DIST. NO.	ILLINOIS	FED. AID PROJECT		
• 109BR-3 & 109BR-4				

# TYPICAL SECTIONS

## ( SN # 098-0022 )

STA. 219+46 - STA. 225+14 & STA. 226+21 - STA. 227+48

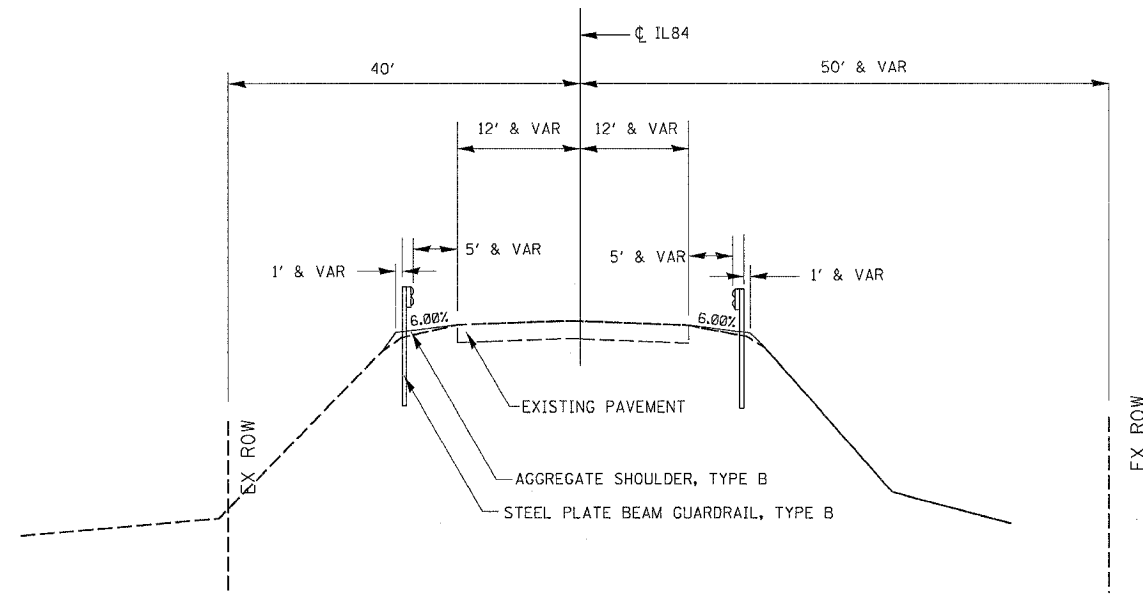

STA. 225+14 - STA. 225+42 & STA. 225+89 - STA. 226+21

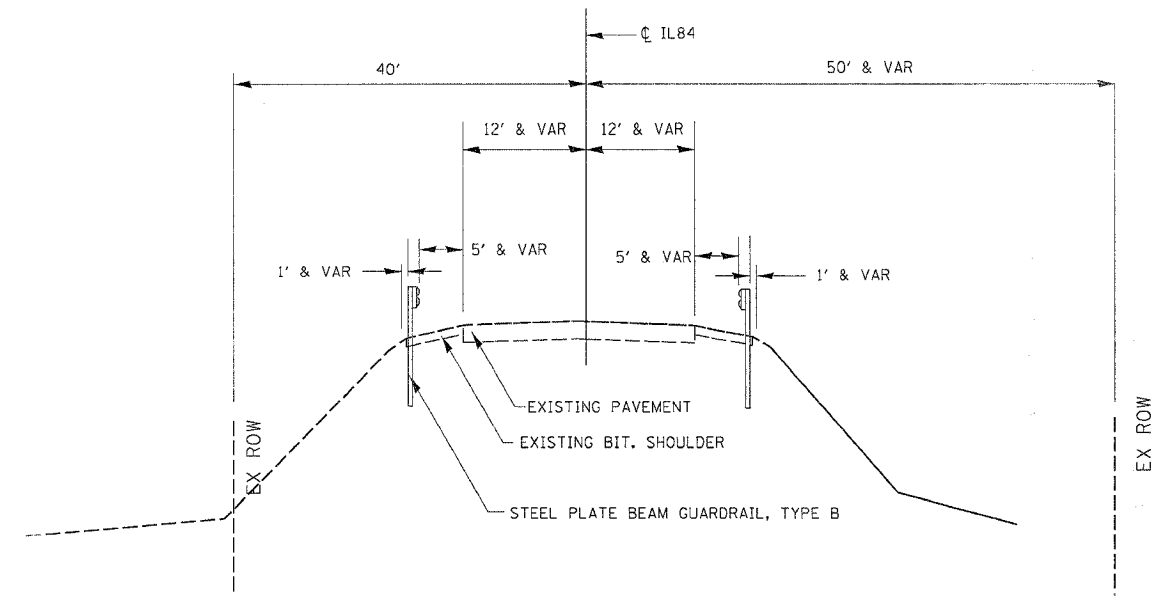

### STAGE 1

STA. 222+90 - STA. 228+40

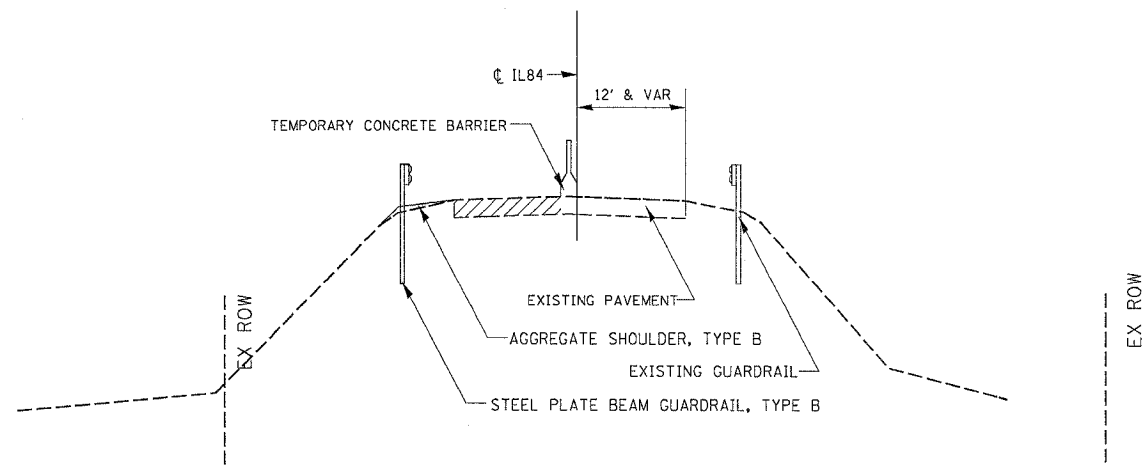

### STAGE 2

STA. 219+46 - STA. 228+40

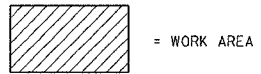
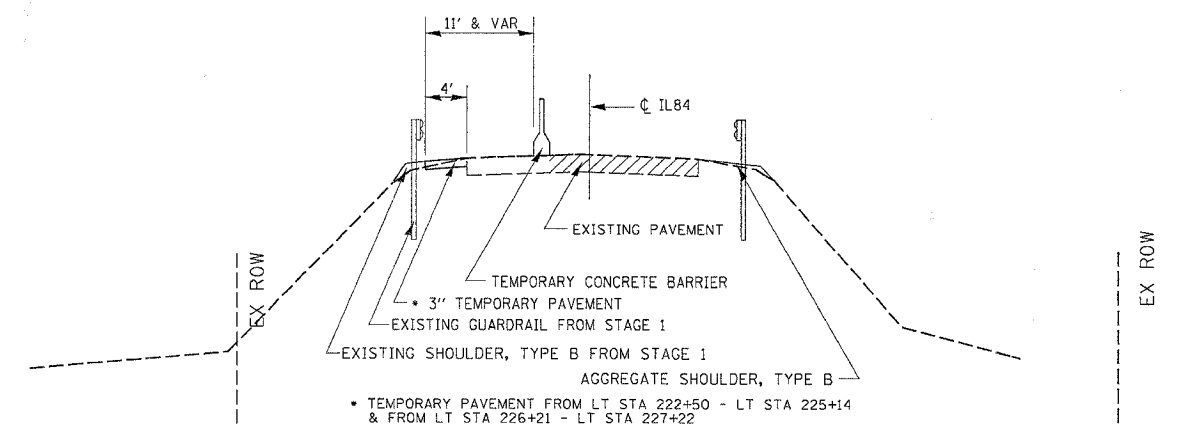

PLOT DATE = Thu Dec 23 18:39:48 2005  
 FILE NAME = c:\p\projects\2005\098\0022\typ.dgn  
 USER = jgoff  
 USER NAME = jgoff

REVISIONS	
NAME	DATE

ILLINOIS DEPARTMENT OF TRANSPORTATION

SCALE: VERT.  
HORIZ.  
DATE

DRAWN BY  
CHECKED BY