

PROPOSED TYPICAL TOWNSHIP ROAD 1750 N SECTION

STA 1+05.33 TO STA 1+94.88

- NOTES:
- 1/2" / FT OR 8% BREAKOVER WHICHEVER IS LESS.
 - 1/2" / FT OR S.E. WHICHEVER IS GREATER.
 - SEE PLAN SHEETS FOR S.E. RATES AND TRANSITIONS.

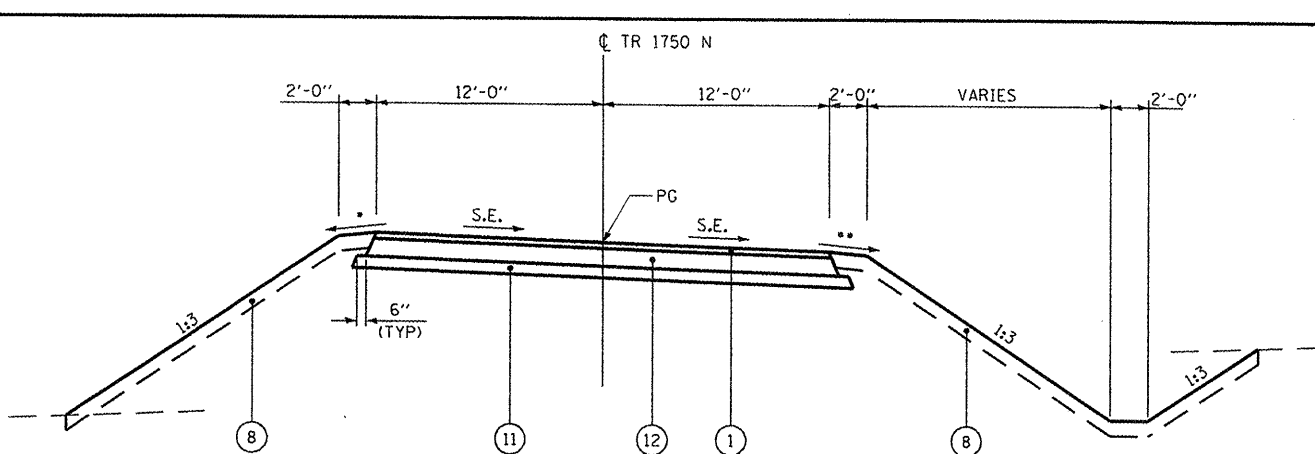

PROPOSED TYPICAL TOWNSHIP ROAD 1750 N SECTION

STA 1+94.88 TO STA 3+75.00

- NOTES:
- 1/2" / FT OR 8% BREAKOVER WHICHEVER IS LESS.
 - 1/2" / FT OR S.E. WHICHEVER IS GREATER.
 - SEE PLAN SHEETS FOR S.E. RATES AND TRANSITIONS.

LEGEND

- (E1) EXISTING HOT-MIX-ASPHALT / PCC PAVEMENT
- (E2) EXISTING HOT-MIX ASPHALT SHOULDER
- (E3) EXISTING PIPE UNDERDRAINS, 4"
- (1) PROPOSED POLYMERIZED HOT-MIX ASPHALT SURFACE COURSE, 2"
- (1A) PROPOSED POLYMERIZED HOT-MIX ASPHALT BINDER COURSE, VARIABLE DEPTH (2 1/4" - 4 1/2")
PROPOSED HOT-MIX ASPHALT BINDER COURSE, VARIABLE DEPTH (2 1/4" - 15 3/4")
- (2) PROPOSED HOT-MIX ASPHALT SHOULDERS, VARIABLE DEPTH (2" - 8")
- (3) PROPOSED AGGREGATE SHOULDERS, TYPE B
- (3A) PROPOSED GUARDRAIL AGGREGATE EROSION CONTROL
- (4) PROPOSED POLYMERIZED HOT-MIX ASPHALT BINDER COURSE, 2 1/4"
PROPOSED HOT-MIX ASPHALT BINDER COURSE, 11 3/4"
- (4A) PROPOSED POLYMERIZED HOT-MIX ASPHALT BINDER COURSE, 2 1/4"
PROPOSED HOT-MIX ASPHALT BINDER COURSE, 4 3/4"
- (5) PROPOSED SUB-BASE GRANULAR MATERIAL, TYPE A, VARIABLE DEPTH (4" - 16")
- (5A) PROPOSED SUB-BASE GRANULAR MATERIAL, TYPE A, 12"
- (6) PROPOSED HOT-MIX ASPHALT SHOULDERS, 8"
- (7) PROPOSED SUB-BASE GRANULAR MATERIAL, TYPE C (VARIABLE DEPTH)
- (8) PROPOSED TOPSOIL, 4"
- (10) PROPOSED STEEL PLATE BEAM GUARDRAIL, TYPE A
- (11) PROPOSED SUB-BASE GRANULAR MATERIAL, TYPE A, 4"
- (12) PROPOSED HOT-MIX ASPHALT BINDER COURSE, 6"
- (13) PROPOSED EMBANKMENT
- (14) PROPOSED HOT-MIX ASPHALT BINDER COURSE, 7"
- (15) PROPOSED AGGREGATE BASE COURSE, TYPE A 6"

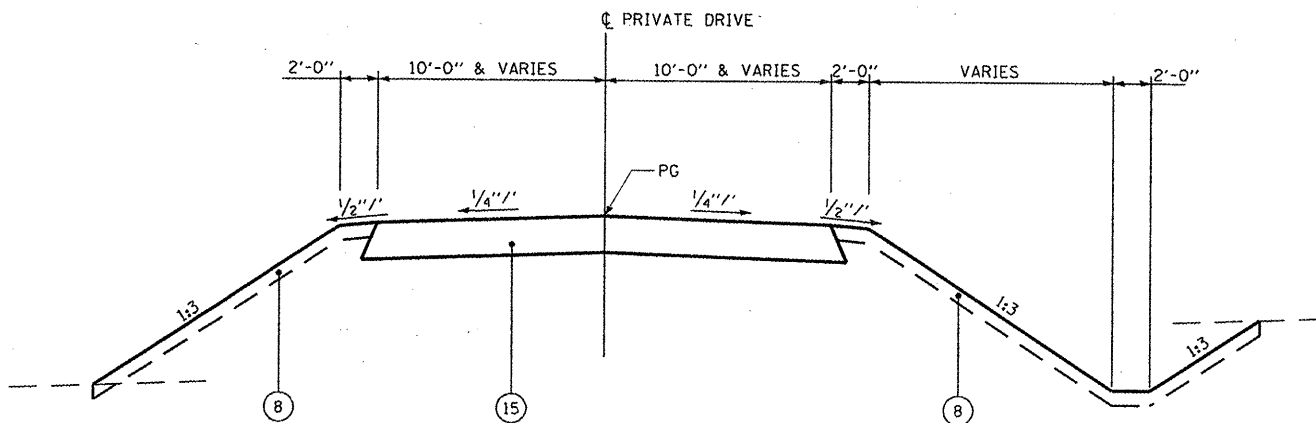

PROPOSED TYPICAL PRIVATE DRIVE 151 SECTION

STA 18+25.00 TO STA 19+74.44

- NOTES:
- 1) AN 8" APRON SHALL BE CONSTRUCTED ADJACENT TO THE HMA SHOULDER CONSISTING OF 3 1/2" INCIDENTAL HMA SURFACING & 6" AGG BSE CSE, TY A. (SEE PLAN SHEETS)

FILE NAME =	USER NAME = seb	DESIGNED -	REVISED -
p:\07files\070286\phase2\cadd sheets\06691-sht-typical.dgn		DRAWN -	REVISED -
		CHECKED -	REVISED -
		DATE -	REVISED -

STATE OF ILLINOIS
DEPARTMENT OF TRANSPORTATION

PROPOSED
TYPICAL SECTIONS

SCALE: none SHEET NO. 5 OF 5 SHEETS STA. TO STA.

F.A.P. RTE.	SECTION	COUNTY	TOTAL SHEETS	SHEET NO.
310	(38B-2)BR	MCDONOUGH	130	12
CONTRACT NO. 68691				
ILLINOIS FED. AID PROJECT				