

STATE OF ILLINOIS  
DEPARTMENT OF TRANSPORTATION

ROUTE NO.	SECTION	COUNTY	TOTAL SHEETS	SHEET NO.	SHEET NO. 12
FAP 662	V.T)B-2	MACOUPIN	66	38	20 SHEETS
FED. ROAD DIST. NO. 7	ILLINOIS	FED. AID PROJECT			

Contract #72993

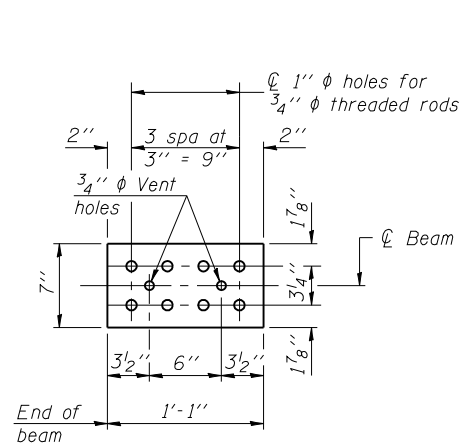

**TOP PLATE**

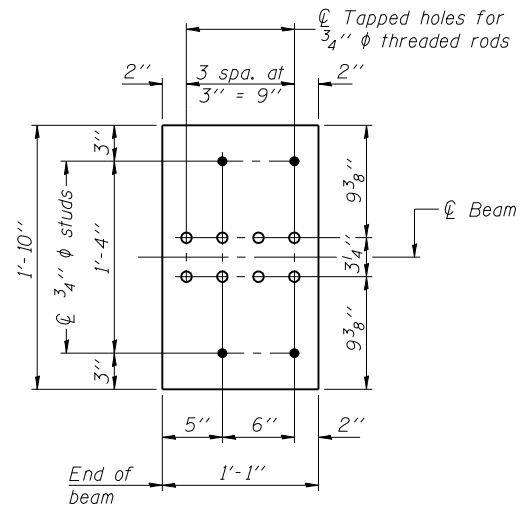

**BOTTOM PLATE**

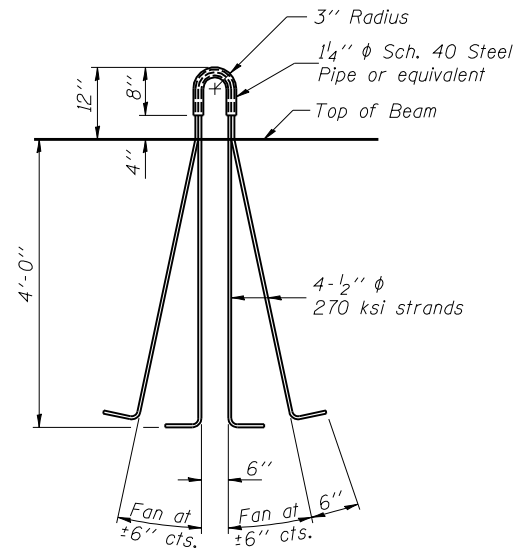

**LIFTING LOOP DETAIL**

**NOTES**

Inserts for 3/4"  $\phi$  threaded dowel rods, when specified, are to be two strut, coil type for interior beams and single coil, flared loop type for exterior beams.  
 Prestressing steel shall be uncoated high strength, low relaxation 7-wire strand, Grade 270.  
 The nominal diameter shall be 1/2" and the nominal cross-sectional area shall be 0.153 sq. in.  
 Non-prestressing steel shall conform to ASTM A 706 (IL MOD), Grade 60.  
 A minimum 2 1/2"  $\phi$  lifting pin shall be used to engage the lifting loops during handling.  
 The bottom plates and studs shall be galvanized according to AASHTO M 111.  
 Threaded rods shall be ASTM F 1554 Grade 55.  
 The cut strands at each beam end shall be given two coats of zinc dust spray or paint meeting the requirements of ASTM A 780. The zinc dust spray or paint shall be applied before corrosion appears and allowed to dry according to the manufacturer's specifications prior to another coat of zinc. A concrete sealer meeting the requirements of Section 587 of the Standard Specifications shall be applied to all portions of the I-beam or Bulb-T beam, except the top surface of the top flange and the bottom surface of the bottom flange, starting at each beam end and extending out a distance of 54 inches. The sealer shall be applied after visible crack growth has subsided. This work shall be performed by the producer and included with the cost of the beam.

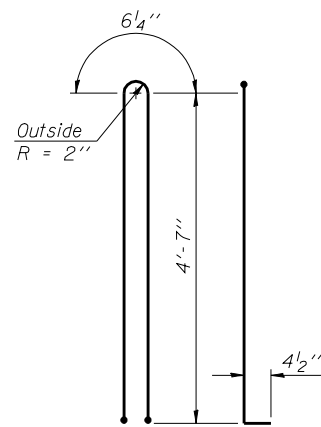

**BAR G1**

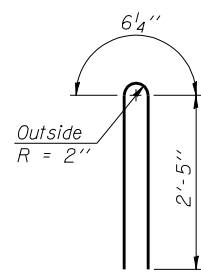

**BAR G2**

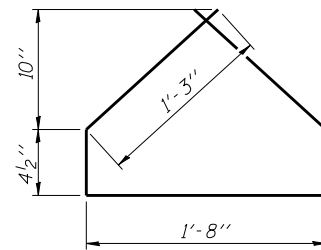

**BAR G4**

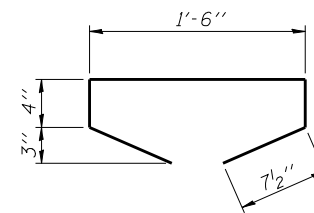

**BAR G5**

**BILL OF MATERIAL**

Item	Unit	Total
Furnishing and Erecting Precast Prestressed Concrete I-Beams, 54"	Ft.	524.5

DESIGNED	DPN
CHECKED	AJB
DRAWN	h.t. duong
CHECKED	FT/AJB/DPN

Jan 23, 2007  
 EXAMINED *Thomas J. Domagala*  
 ENGINEER OF BRIDGE DESIGN  
 PASSED *Ralph E. Anderson*  
 ENGINEER OF BRIDGES AND STRUCTURES

**54" PPC I-BEAM DETAILS**  
**F.A.P. RT. 662 SECTION (V.T)B-2**  
**MACOUPIN COUNTY**  
**STATION 447+03.80**  
**STRUCTURE NO. 059-0504**