

STATE OF ILLINOIS
DEPARTMENT OF TRANSPORTATION

ROUTE NO.	SECTION	COUNTY	TOTAL SHEETS	SHEET NO.	SHEET NO. 4
FAP 662	V.T)B-2	MACOUPIN	66	30	20 SHEETS
FED. ROAD DIST. NO. 7	ILLINOIS	FED. AID PROJECT			

Contract #72993

When "A" is 3'-6" or less, the temporary concrete barrier shall be anchored to the new slab according to Detail I or Detail II. No anchorage is required when "A" is greater than 3'-6".

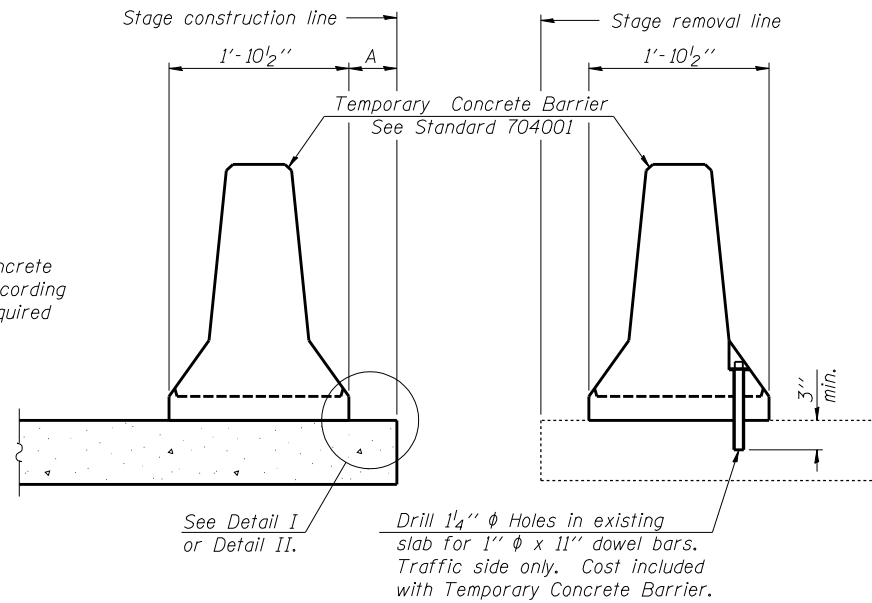

NEW SLAB

EXISTING SLAB

SECTIONS THRU SLAB

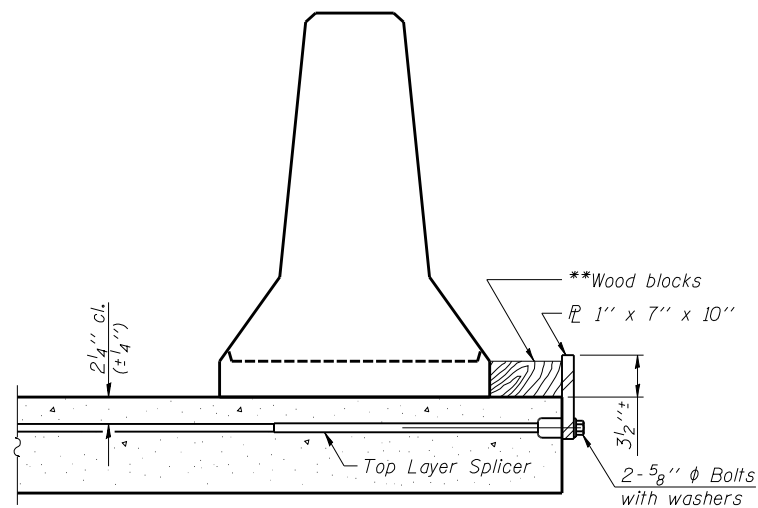

DETAIL I

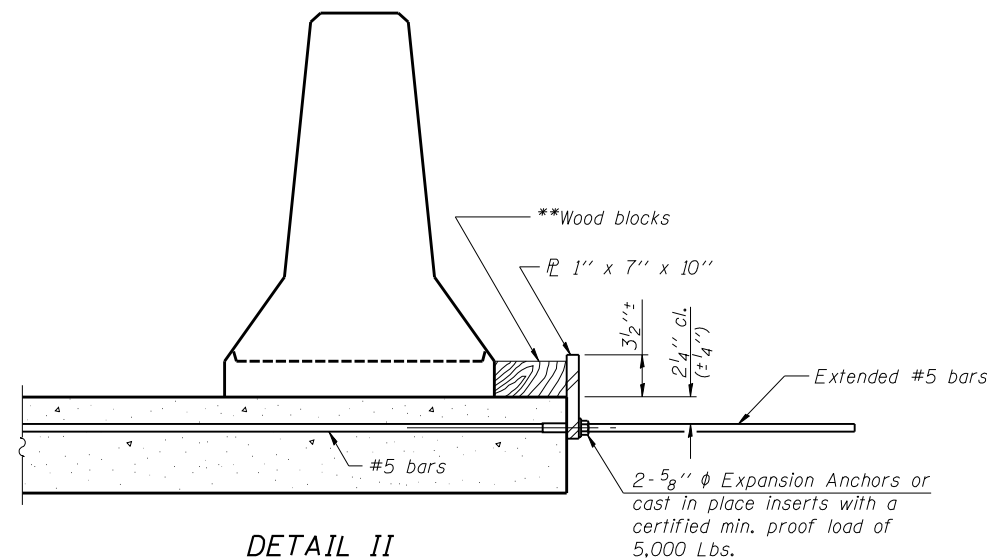

DETAIL II

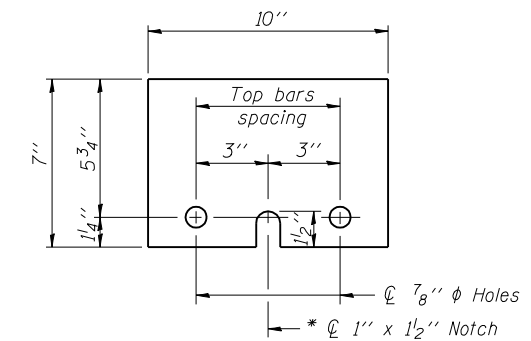

STEEL RETAINER 1" x 7" x 10"

* Required only with Detail II

** Wood blocks may be omitted when required to provide minimum stage traffic lane width. When the wood blocks are omitted, the concrete barrier shall be in direct contact with the steel retainer plate.

DESIGNED	DPN
CHECKED	AJB
DRAWN	h.t. duong
CHECKED	FT/AJB/DPN

Jan 23, 2007
EXAMINED *Thomas J. Domagala*
ENGINEER OF BRIDGE DESIGN
PASSED *Ralph E. Anderson*
ENGINEER OF BRIDGES AND STRUCTURES

R-27

11-1-06

TEMPORARY CONCRETE BARRIER
FOR STAGE CONSTRUCTION
F.A.P. RT. 662 - SECTION (V,T)B-2
MACOUPIN COUNTY
STATION 447+03.80
STRUCTURE NO. 059-0504