

STATE OF ILLINOIS
DEPARTMENT OF TRANSPORTATION

FAU RTE 2513 1031	SECTION 23-00363-00-RS	COUNTY KANE	TOTAL SHEETS 21	SHEET NO. 1
ILLINOIS		CONTRACT NO. 61K23		

FOR INDEX OF SHEETS, SEE SHEET NO. 2
FOR LIST OF HIGHWAY STANDARDS SEE SHEET NO. 2

FUNCTIONAL CLASSIFICATION
CHURCH RD - MAJOR COLLECTOR
SHEFFER RD - MAJOR COLLECTOR

TRAFFIC DATA
CHURCH RD
2018 ADT = 10,800
SHEFFER RD
2018 ADT = 4,150

POSTED SPEED LIMIT
CHURCH RD = 30 MPH
SHEFFER RD = 30 MPH

DESIGN SPEED LIMIT
CHURCH RD = 30 MPH
SHEFFER RD = 30 MPH

PLANS FOR PROPOSED FEDERAL AID HIGHWAY

FAU ROUTE 2513 AND MUN 1031 (CHURCH RD. AND SHEFFER RD.)
INDIAN TRAIL TO SHEFFER RD. AND CHURCH RD. TO OHIO ST.
ROADWAY RESURFACING
SECTION NO.: 23-00363-00-RS
PROJECT NO.: 63KP(575)
CITY OF AURORA
KANE COUNTY



FEDERAL AID PROGRAM ENGINEER: CARMEN E. RAMOS, P.E., SCHAUMBURG, IL

C-91-176-23

RANGE 8 EAST

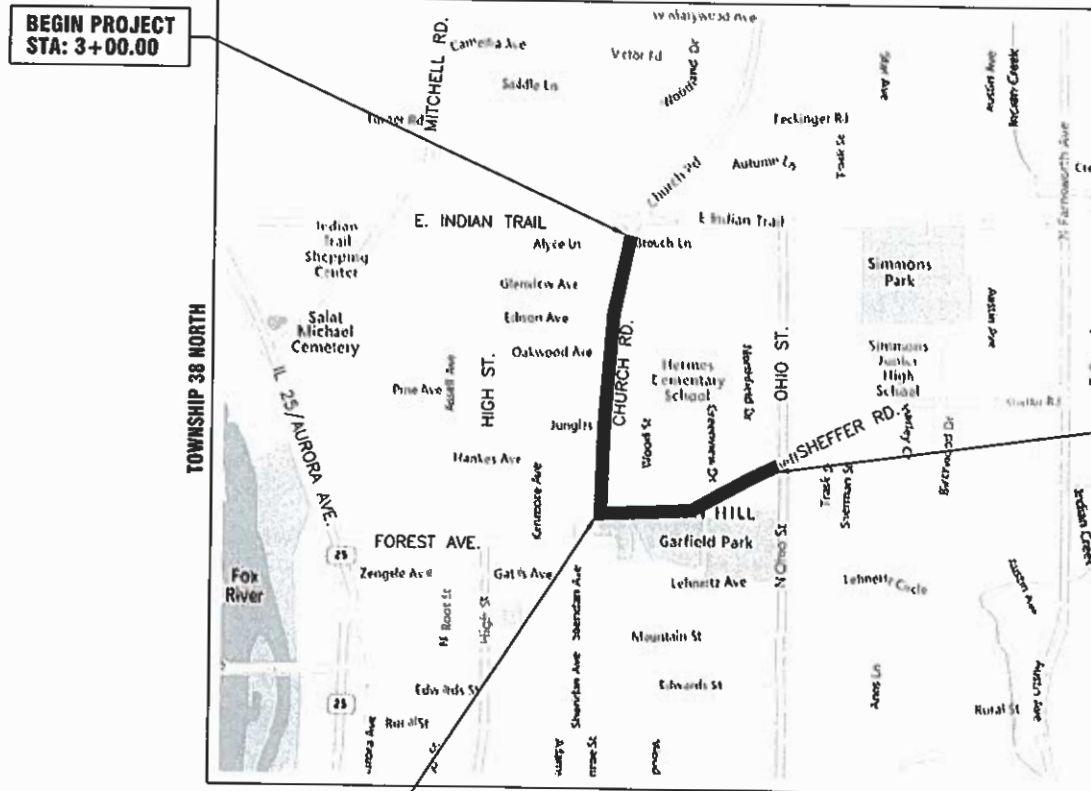

KANE COUNTY - SUGAR GROVE TOWNSHIP
THIRD PRINCIPAL MERIDIAN

LOCATION MAP
NOT TO SCALE

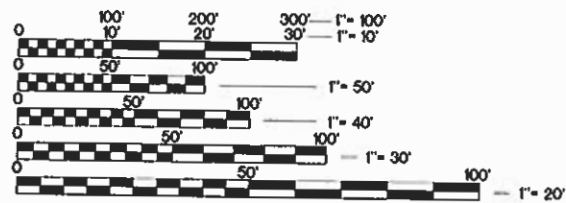

FULL SIZE PLANS HAVE BEEN PREPARED USING STANDARD
ENGINEERING SCALES. REDUCED SIZED PLANS WILL NOT
CONFORM TO STANDARD SCALES. IN MAKING MEASUREMENTS
ON REDUCED PLANS, THE ABOVE SCALES MAY BE USED.

J.U.L.I.E.
JOINT UTILITY LOCATION INFORMATION FOR EXCAVATION
811 OR 1-800-892-0123

Dial 811 or 1-800-892-0123 JULIE DESIGN TICKET NUMBER: # A231651142

WITH THE FOLLOWING:
COUNTY KANE COUNTY
CITY-TOWNSHIP AURORA-AURORA TOWNSHIP
SEC. & 1/4 SEC. NO. # 1,14-38 N-8 E.

(2) Working Days before you dig
(Excluding Sat., Sun. & Holidays)

Know what's below.
Call before you dig.

CONTRACT NO. 61K23

GROSS LENGTH OF PROJECT = 4,203.8 FEET (0.796 MILES)
NET LENGTH OF PROJECT = 4,203.8 FEET (0.796 MILES)

STATE OF ILLINOIS
DEPARTMENT OF TRANSPORTATION

APPROVED December 21 2023
Timothy V. Weidner
CITY OF AURORA, ENGINEERING COORDINATOR

PASSED Jan 3 2024
C. H. Hale
DISTRICT 1 ENGINEER OF LOCAL ROADS & STREETS

RELEASING FOR BID
BASED ON LIMITED
REVIEW Jan 3 2024
Jose Rios
REGIONAL ENGINEER

THIMOTHY V. WEIDNER
082-058548
REGISTERED
PROFESSIONAL
ENGINEER
OF
EX-1130/2025
ILLINOIS

SEAL
Timothy V. Weidner
TIMOTHY V. WEIDNER, P.E.
EXPIRES: NOVEMBER 30, 2025

PLANS PREPARED BY
THE CITY OF AURORA

PRINTED BY THE AUTHORITY
OF THE STATE OF ILLINOIS

INDEX OF SHEETS

SHEET NO.	DESCRIPTION
1	COVER SHEET
2	INDEX OF SHEETS, DETAILS, HIGHWAY STANDARDS AND GENERAL NOTES
3 - 5	SUMMARY OF QUANTITIES
6 - 7	TYPICAL SECTIONS
8 - 12	RESURFACING PLAN
13	EROSION CONTROL DETAILS
14 - 21	I.D.O.T. DISTRICT 1 DETAILS

ILLINOIS URBAN MANUAL EROSION CONTROL DETAILS

IUM-654SB	TEMPORARY CONCRETE WASHOUT FACILITY - STRAW BALE
IUM-561C	INLET PROTECTION - PAVED AREAS CURB PROTECTION
IUM-561D	INLET PROTECTION - PAVED AREAS DROP-IN PROTECTION

DISTRICT ONE DETAILS

BD-08	DETAILS FOR FRAMES AND LIDS ADJUSTMENT WITH MILLING
BD-22	PAVEMENT PATCHING FOR HMA SURFACED PAVEMENT
BD-24	CURB OR CURB AND GUTTER REMOVAL AND REPLACEMENT
BD-32	BUTT JOINT AND HMA TAPER DETAILS
TC-10	TRAFFIC CONTROL AND PROTECTION FOR SIDE ROADS, INTERSECTIONS, AND DRIVEWAYS
TC-13	DISTRICT ONE TYPICAL PAVEMENT MARKINGS
TC-16	SHORT TERM PAVEMENT MARKING LETTERS AND SYMBOLS
TC-22	ARTERIAL ROAD INFORMATION SIGN

HIGHWAY STANDARDS

000001-08	STANDARD SYMBOLS, ABBREVIATIONS AND PATTERNS
001006	DECIMAL OF AN INCH AND OF A FOOT
280001-07	TEMPORARY EROSION CONTROL SYSTEMS
420001-10	PAVEMENT JOINTS
442201-03	CLASS C AND D PATCHES
604001-05	FRAME AND LIDS TYPE 1
604051-04	FRAME AND LIDS TYPE 11
606001-08	CONCRETE CURB TYPE B AND COMBINATION CONCRETE CURB AND GUTTER
701006-05	OFF-RD OPERATIONS, 2L, 2W, 15' (4.5M) TO 24" (600 MM) FROM PAVEMENT EDGE
701301-04	LANE CLOSURE, 2L, 2W, SHORT TIME OPERATIONS
701311-03	LANE CLOSURE, 2L, 2W, MOVING OPERATIONS-DAY ONLY
701501-06	URBAN LANE CLOSURE, 2L, 2W, UNDIVIDED
701801-06	SIDEWALK, CORNER OR CROSSWALK CLOSURE
701901-09	TRAFFIC CONTROL DEVICES
780001-05	TYPICAL PAVEMENT MARKINGS

GENERAL NOTES

- ALL REFERENCES TO "STANDARD SPECIFICATIONS" IN THESE GENERAL NOTES SHALL BE INTERPRETED TO MEAN THE ILLINOIS DEPARTMENT OF TRANSPORTATION "STANDARD SPECIFICATIONS FOR ROAD AND BRIDGE CONSTRUCTION", JANUARY 1, 2022 AND SUPPLEMENTAL SPECIFICATIONS AND RECURRING SPECIAL PROVISIONS, JANUARY 1, 2024.
- IT SHALL BE THE CONTRACTOR'S RESPONSIBILITY TO VERIFY ALL DIMENSIONS AND CONDITIONS EXISTING IN THE FIELD PRIOR TO CONSTRUCTION AND ORDERING OF MATERIALS. IN ADDITION, THE CONTRACTOR MUST VERIFY THE ENGINEER'S LINE AND GRADE STAKES. IN THE EVENT OF A DISCREPANCY BETWEEN THE PLANS AND FIELD CONDITIONS, THE CONTRACTOR SHALL SECURE WRITTEN INSTRUCTIONS FROM THE ENGINEER PRIOR TO PROCEEDING WITH ANY PART OF THE WORK AFFECTED BY THE IDENTIFIED DISCREPANCIES.
- BEFORE STARTING ANY EXCAVATION, THE CONTRACTOR SHALL CALL "JULIE" (JOINT UTILITY LOCATION INFORMATION FOR EXCAVATION) AT (800) 892-0123 FOR FIELD LOCATIONS OF BURIED UTILITIES (48 HOURS NOTIFICATION IS REQUIRED).
- THE CONTRACTOR SHALL BE RESPONSIBLE FOR CONTACTING THE OWNER OF ALL EXISTING UTILITIES FACILITIES SO THAT THE UTILITIES AND THEIR APPURTENANCES MAY BE LOCATED AND ADJUSTED OR MOVED, IF NECESSARY, PRIOR TO THE START OF CONSTRUCTION OPERATIONS.
- THE CONTRACTOR WILL NOT BE ALLOWED TO SET UP A YARD OR FIELD OFFICE ON CITY, STATE, OR PRIVATE PROPERTY WITHOUT WRITTEN PERMISSION FROM THE ENGINEER.
- THE STORAGE OF EQUIPMENT AND/OR MATERIALS WITHIN THE RIGHT-OF-WAY OF ANY STREET AND/OR PARK PROPERTY SHALL REQUIRE PRIOR APPROVAL OF THE ENGINEER.
- OFFSET LOCATIONS GIVEN IN THE PLANS FOR STRUCTURES, EDGE OF PAVEMENT, ETC. ARE FROM THE ROADWAY CENTERLINE.
- SIDEWALK REMOVAL AND REPLACEMENT AND COMBINATION CONCRETE CURB AND GUTTER REMOVAL AND REPLACEMENT AS SHOWN ON THE PLANS IS FOR INFORMATIONAL PURPOSES ONLY. ACTUAL LOCATIONS AND QUANTITIES ARE TO BE DETERMINED AND MARKED BY THE ENGINEER PRIOR TO CONSTRUCTION.
- THE CONTRACTOR SHALL BE RESPONSIBLE FOR THE REPLACEMENT OF ANY DETECTOR LOOPS DAMAGED DURING CONSTRUCTION.
- BUTT JOINTS WILL BE INSTALLED AT THE ENDS OF RESURFACING (WHERE RESURFACING MEETS EXISTING PAVEMENT) IN ACCORDANCE WITH THE "BUTT JOINT AND HMA TAPER DETAILS" SHEET INCLUDED IN THE PLANS.
- THE CONTRACTOR SHALL VERIFY THAT ALL CRACKS, JOINTS, AND FLANGEWAYS ARE CLEAN AND DRY PRIOR TO PLACEMENT OF MIXTURE FOR CRACKS, JOINTS, AND FLANGEWAYS.
- THE CONTRACTOR SHALL MAINTAIN THE SITE IN A CLEAN AND ORDERLY MANNER. DEBRIS AND SURPLUS MATERIAL SHALL BE REMOVED AND RESTORATION SHALL PROCEED AS THE WORK PROCEEDS. IF THE ENGINEER SO DIRECTS, THE CONTRACTOR SHALL STOP ALL OTHER WORK AND CONCENTRATE ON CLEAN-UP AND RESTORATION. DEBRIS AND SURPLUS MATERIAL SHALL BE DISPOSED BY THE CONTRACTOR OFF-SITE.
- DRIVEWAY ENTRANCES WILL BE KEPT OPEN TO TRAFFIC AT ALL TIMES. THE CONTRACTOR WILL BE ALLOWED TO CLOSE A MAXIMUM OF HALF THE AREA OF ANY ONE ENTRANCE AT ANY TIME. IT IS ESSENTIAL THAT THE ENTRANCES REMAIN OPEN AND 'DRIVE-ABLE' FOR TWO-WAY TRAFFIC AT ALL TIMES. THE CONTRACTOR WILL BE RESPONSIBLE FOR MAINTAINING TRAFFIC CONTROL AND PROTECTION. WHERE NEW CURB AND GUTTER IS TO BE INSTALLED ACROSS A DRIVEWAY, IT IS EXPECTED THAT ONLY HALF OF THE DRIVEWAY ENTRANCE MAY BE REMOVED AND REPLACED AT ANY ONE TIME. ONLY AFTER PROPER CONCRETE CURE TIME HAS OCCURRED MAY THE CONTRACTOR BEGIN REMOVAL AND REPLACEMENT OPERATIONS ON THE REMAINING HALF OF THE CURB AND GUTTER. THE CONTRACTOR WILL NOT BE ALLOWED TO CLOSE A HALF OF DRIVEWAY ENTRANCE FOR MORE THAN 48 HOURS UNDER ANY CIRCUMSTANCE.
- CONTRACTOR SHALL TAKE PRECAUTION BY PRESERVING EXISTING TREES WITHIN THE RIGHT OF WAY. IF ANY DAMAGE OCCURS, TREES SHALL BE REPLACED IN KIND PER ARTICLE 201.07 REPAIR OR REPLACEMENT OF EXISTING PLANT MATERIAL REQUIREMENTS STATED HEREIN
- WHEN MILLED PAVEMENT IS OPEN TO TRAFFIC, THE MAXIMUM GRADE DIFFERENTIAL BETWEEN PASSES OF THE MILLING MACHINE SHALL NOT EXCEED 1.5 INCHES WHERE THE SPEED IS 45 MPH OR LESS, WITH WRITTEN APPROVAL FROM THE RESIDENT ENGINEER, A MAXIMUM GRADE DIFFERENTIAL OF 3 INCHES MAY BE ALLOWED IF THE EDGE OF THE MILLING IS SLOPED A MINIMUM OF 1V:3H.
- ALL PHOSPHOROUS FERTILIZER NUTRIENT HAS BEEN INTENTIONALLY OMITTED FROM THE CONTRACT ON THE SODDING APPLICATION.
- THE CONTRACTOR SHALL CONTACT KALPANA KANNAN-HOSADURGA, THE DISTRICT ONE TRAFFIC CONTROL SUPERVISOR AT KALPANA.KANNAN-HOSADURGA@ILLINOIS.GOV A MINIMUM 72 HOURS IN ADVANCE OF BEGINNING WORK.
- THE CONTRACTOR SHALL COORDINATE WITH THE CONTRACTOR FOR IDOT CONTRACT 61H85 (INDIAN TRAIL RECONSTRUCTION).

UTILITIES

- ALL UTILITY COMPANIES AND THE CITY OF AURORA SHALL BE NOTIFIED AT LEAST 3 DAYS PRIOR TO THE START OF CONSTRUCTION.
- EXISTING BROKEN FRAMES AND LIDS SHALL BE REMOVED AND DISPOSED OF BY THE CONTRACTOR AND SHALL BE REPLACED AS DIRECTED BY THE ENGINEER.
- ONLY PRECAST CONCRETE ADJUSTMENT RINGS, MAXIMUM OF 12 INCHES IN HEIGHT, WILL BE ALLOWED IN THE ADJUSTMENT OF CATCH BASINS, MANHOLES, INLETS AND VALVE VAULT STRUCTURES. COMMON BRICK WILL NOT BE ALLOWED.
- THE CONTRACTOR SHALL ENSURE THAT ALL WATER SYSTEM VALVES (IN VALVE BOXES AND VALVE VAULTS) SHALL REMAIN READILY ACCESSIBLE TO THE CITY FOR EMERGENCY OPERATIONS AND NOT BURIED DURING CONSTRUCTION, UNLESS APPROVED BY THE ENGINEER. THE LOCATIONS OF ALL WATER FACILITIES SHALL BE MARKED AND READILY VISIBLE AT ALL TIMES. FOR ALL OTHER STRUCTURES THAT NEED TO BE ADJUSTED THAT ARE NOT WATER, THE CONTRACTOR CAN CHOOSE TO ADJUST THEM ACCORDING TO BD-08. THE CONTRACTOR CAN ALSO CHOOSE TO BURY WATER STRUCTURES ACCORDING TO BD-08 WITH APPROVAL BY THE ENGINEER. THE CONTRACTOR WOULD NEED TO PROVIDE A DETAILED SCHEDULE OF MILLING, PAVING, AND ADJUSTMENT TIMELINES FOR THE ENGINEER'S REVIEW. APPROVAL BY THE ENGINEER IS NOT GUARANTEED AND WOULD BE CONTINGENT ON THE CONTRACTOR BURYING WATER STRUCTURES LAST AND ADJUSTING THEM FIRST. THE CONTRACTOR IS TO DETERMINE ANY PROTECTION OR RAMPING THAT IS REQUIRED AROUND STRUCTURES IF THEY ARE NOT BURIED. OPEN LID STORM MANHOLE STRUCTURES IN THE PAVEMENT MAY NOT BE ABLE TO BE ADJUSTED ACCORDING TO BD-08.
- THE INDISCRIMINATE USE OF FIRE HYDRANTS OR EXISTING STREAMS, CREEKS, WETLANDS OR PONDS IS STRICTLY PROHIBITED. THE CONTRACTOR SHALL PROVIDE A WATER TRUCK AND DRIVER AS REQUIRED TO OBTAIN AND TRANSPORT THIS WATER. THE CONTRACTOR SHALL BE RESPONSIBLE FOR OBTAINING WATER FROM AN APPROVED SOURCE. IF THIS WATER IS FROM A SOURCE OTHER THAN THEIR YARD, WRITTEN APPROVAL FROM THE AGENCY HAVING JURISDICTION FOR THE SOURCE OF THE WATER MUST BE RECEIVED BY THE ENGINEER PRIOR TO USE OF THE WATER.

SIGNING AND STRIPING

- ALL EXISTING SIGNS (INCLUDING THOSE LOCATED ON UTILITY/LIGHT POLES) THAT DO NOT CONFLICT WITH THE IMPROVEMENTS SHALL REMAIN IN PLACE UNLESS DIRECTED BY THE ENGINEER.
- SIGNS SHALL NOT BE MOVED OR COVERED UNTIL PROGRESS OF WORK NECESSITATES IT.
- SEE IDOT DISTRICT ONE DETAILS TC-13 (DISTRICT ONE TYPICAL PAVEMENT MARKINGS), AND TC-16 (SHORT TERM PAVEMENT MARKINGS LETTERS AND SYMBOLS) AND PLAN SHEETS FOR PAVEMENT MARKING DETAILS.
- GRINDING OF PAVEMENT MARKINGS ON NEWLY CONSTRUCTED HOT-MIX ASPHALT SHALL NOT BE PERMITTED.

COMMITMENTS

NONE AS OF 11/22/2023

COMPANY NAME: PROJECT CONTACT: 12/21/2023 12:57 PM
 CLIENT: Church-Cover-Ph2
 DATE PLOTTED: Church-Cover-Ph2
 FILE NAME: DWG To PDF.pc3
 PLOT DRIVER: ILDOT-Standard.ctb
 PEN TABLE:

USER NAME = HOPPM	DESIGNED -- AN	REVISED --
FILE NAME = Church-Cover-Ph2	DRAWN -- MH	REVISED --
PLOT SCALE = N.T.S.	CHECKED -- TW	REVISED --
PLOT DATE = 12/21/2023	DATE -- 09/18/2023	REVISED --

**STATE OF ILLINOIS
 DEPARTMENT OF TRANSPORTATION**

INDEX OF SHEETS, DETAILS, HIGHWAY STANDARDS AND GENERAL NOTES

SCALE: N.T.S. SHEET NO. 01 OF 01 SHEETS STA. TO STA.

FAU RTE.	SECTION	COUNTY	TOTAL SHEETS	SHEET NO.
2513 1031	23-00363-00-RS	KANE	21	2
CONTRACT NO. 61K23				
ILLINOIS FED. AID PROJECT				

CODE NUMBER	ITEM DESCRIPTION	UNIT	TOTAL QUANTITY 75% FEDERAL 25% LOCAL 0005
20101400	NITROGEN FERTILIZER NUTRIENT	POUND	2
20101600	POTASSIUM FERTILIZER NUTRIENT	POUND	2
21101615	TOPSOIL FURNISH AND PLACE, 4"	SQ YD	97
25200110	SODDING, SALT TOLERANT	SQ YD	97
25200200	SUPPLEMENTAL WATERING	UNIT	5.3
31101000	SUBBASE GRANULAR MATERIAL, TYPE B	TON	43
40600290	BITUMINOUS MATERIALS (TACK COAT)	POUND	10175
40600370	LONGITUDINAL JOINT SEALANT	FOOT	4140
40600400	MIXTURE FOR CRACKS, JOINTS, AND FLANGEWAYS	TON	6.0
40600982	HOT-MIX ASPHALT SURFACE REMOVAL - BUTT JOINT	SQ YD	159
40603200	POLYMERIZED HOT-MIX ASPHALT BINDER COURSE, IL-4.75, N50	TON	829
40604060	HOT-MIX ASPHALT SURFACE COURSE, IL-9.5, MIX "D", N50	TON	1689
42400200	PORTLAND CEMENT CONCRETE SIDEWALK 5 INCH	SQ FT	825
42400800	DETECTABLE WARNINGS	SQ FT	110
44000100	PAVEMENT REMOVAL	SQ YD	28
44000161	HOT-MIX ASPHALT SURFACE REMOVAL, 3"	SQ YD	15073

† INDICATES SPECIALTY ITEM

COMPANY NAME:
PROJECT CONTACT:
CLIENT:
DATE PLOTTED:
FILE NAME:
PLOT SCALE = N.T.S.
PLOT DATE = 12/21/2023

12/21/2023 12:57 PM
Church-Cover-1R2
DWG. 16 PDF 903
LOT-Driver
LOT-Standard

USER NAME = HOPPM	DESIGNED -- AN	REVISED --
FILE NAME = Church-Cover-Ph2	DRAWN -- MH	REVISED --
PLOT SCALE = N.T.S.	CHECKED -- TW	REVISED --
PLOT DATE = 12/21/2023	DATE -- 09/18/2023	REVISED --

STATE OF ILLINOIS
DEPARTMENT OF TRANSPORTATION

SUMMARY OF QUANTITIES

SCALE: N.T.S. SHEET NO. 01 OF 03 SHEETS STA. TO STA.

FAU RTE. 2513 1033	SECTION 23-00363-00-RS	COUNTY KANE	TOTAL SHEETS 21	SHEET NO. 3
ILLINOIS FED. AID PROJECT			CONTRACT NO. 61K23	

CODE NUMBER	ITEM DESCRIPTION	UNIT	TOTAL QUANTITY 75% FEDERAL 25% LOCAL 0005
44000500	COMBINATION CURB AND GUTTER REMOVAL	FOOT	40
44000600	SIDEWALK REMOVAL	SQ FT	675
44201737	CLASS D PATCHES, TYPE I, 8 INCH	SQ YD	60
44201741	CLASS D PATCHES, TYPE II, 8 INCH	SQ YD	120
44201745	CLASS D PATCHES, TYPE III, 8 INCH	SQ YD	240
44201747	CLASS D PATCHES, TYPE IV, 8 INCH	SQ YD	180
48102100	AGGREGATE WEDGE SHOULDER, TYPE B	TON	106
60255500	MANHOLES TO BE ADJUSTED	EACH	7
60260100	INLETS TO BE ADJUSTED	EACH	26
60261300	INLETS TO BE ADJUSTED WITH NEW TYPE 11 FRAME AND GRATE	EACH	1
60265700	VALVE VAULTS TO BE ADJUSTED	EACH	8
60266600	VALVE BOXES TO BE ADJUSTED	EACH	8
60603800	COMBINATION CONCRETE CURB AND GUTTER, TYPE B-6.12	FOOT	50
67100100	MOBILIZATION	L SUM	1
70102620	TRAFFIC CONTROL AND PROTECTION, STANDARD 701501	L SUM	1
70102640	TRAFFIC CONTROL AND PROTECTION, STANDARD 701801	L SUM	1

† INDICATES SPECIALTY ITEM

COMPANY NAME:
PROJECT CONTACT:
CLIENT:
DATE PLOTTED: 12/21/2023 12:57 PM
FILE NAME: Church-Cover-Ph2
PLOT DRIVER: DWG To PDF.pc3
PLOT SCALE: N.T.S.
PLOT DATE: 12/21/2023

USER NAME = HOPPM	DESIGNED -- AN	REVISED --
FILE NAME = Church-Cover-Ph2	DRAWN -- MH	REVISED --
PLOT SCALE = N.T.S.	CHECKED -- TW	REVISED --
PLOT DATE = 12/21/2023	DATE -- 09/18/2023	REVISED --

STATE OF ILLINOIS
DEPARTMENT OF TRANSPORTATION

SUMMARY OF QUANTITIES

SCALE: N.T.S. SHEET NO. 02 OF 03 SHEETS STA. TO STA.

FAU RT.	SECTION	COUNTY	TOTAL SHEETS	SHEET NO.
2513 1051	23-00363-00-RS	KANE	21	4
CONTRACT NO. 61K23				
ILLINOIS FED. AID PROJECT				

CODE NUMBER	ITEM DESCRIPTION	UNIT	TOTAL QUANTITY 75% FEDERAL 25% LOCAL 0005
70300100	SHORT TERM PAVEMENT MARKING	FOOT	1673
70300150	SHORT TERM PAVEMENT MARKING REMOVAL	SQ FT	558
t 78000100	THERMOPLASTIC PAVEMENT MARKING - LETTERS AND SYMBOLS	SQ FT	37
t 78000200	THERMOPLASTIC PAVEMENT MARKING - LINE 4"	FOOT	5625
t 78000400	THERMOPLASTIC PAVEMENT MARKING - LINE 6"	FOOT	356
t 78000600	THERMOPLASTIC PAVEMENT MARKING - LINE 12"	FOOT	648
t 78000650	THERMOPLASTIC PAVEMENT MARKING - LINE 24"	FOOT	174
t 78011000	GROOVING FOR RECESSED PAVEMENT MARKING, LETTERS AND SYMBOLS	SQ FT	37
t 78011025	GROOVING FOR RECESSED PAVEMENT MARKING 5"	FOOT	5625
t 78011035	GROOVING FOR RECESSED PAVEMENT MARKING 7"	FOOT	356
t 78011065	GROOVING FOR RECESSED PAVEMENT MARKING 13"	FOOT	648
t 78011125	GROOVING FOR RECESSED PAVEMENT MARKING 25"	FOOT	174
X4400501	COMBINATION CURB AND GUTTER REMOVAL AND REPLACEMENT LESS THAN OR EQUAL TO 10 FEET	FOOT	60
X4400503	COMBINATION CURB AND GUTTER REMOVAL AND REPLACEMENT GREATER THAN 10 FEET	FOOT	184
X6026050	SANITARY MANHOLES TO BE ADJUSTED	EACH	15
Z0030850	TEMPORARY INFORMATION SIGNING	SQ FT	78

t INDICATES SPECIALTY ITEM

COMPANY NAME:
PROJECT CONTRACT:
CLIENT:
DATE PLOTTED: 12/21/2023 12:57 PM
FILE NAME: Church-Cover-Ph2
PLOT DRIVER: DWG To PDF.pc3
PEN TABLE: EDDI-Standard.ctb

USER NAME = HOPPM	DESIGNED - AN	REVISED -
FILE NAME = Church-Cover-Ph2	DRAWN - MH	REVISED -
PLOT SCALE = N.T.S.	CHECKED - TW	REVISED -
PLOT DATE = 12/21/2023	DATE - 09/18/2023	REVISED -

STATE OF ILLINOIS
DEPARTMENT OF TRANSPORTATION

SUMMARY OF QUANTITIES

SCALE: N.T.S. SHEET NO. 03 OF 03 SHEETS STA. TO STA.

FAU RT.	SECTION	COUNTY	TOTAL SHEETS	SHEET NO.
2513 1051	23-00363-00-RS	KANE	21	5
CONTRACT NO. 61K23				
ILLINOIS FED. AID PROJECT				

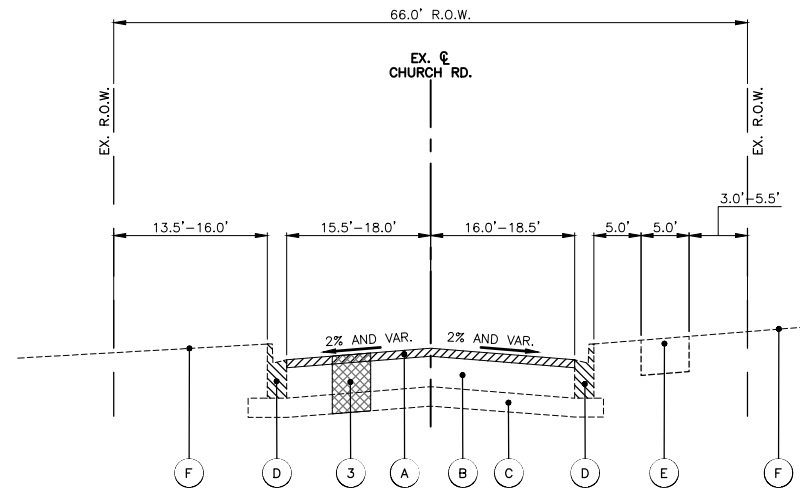

EXISTING TYPICAL SECTION - CHURCH RD.
STA: 3+00 - STA: 16+53

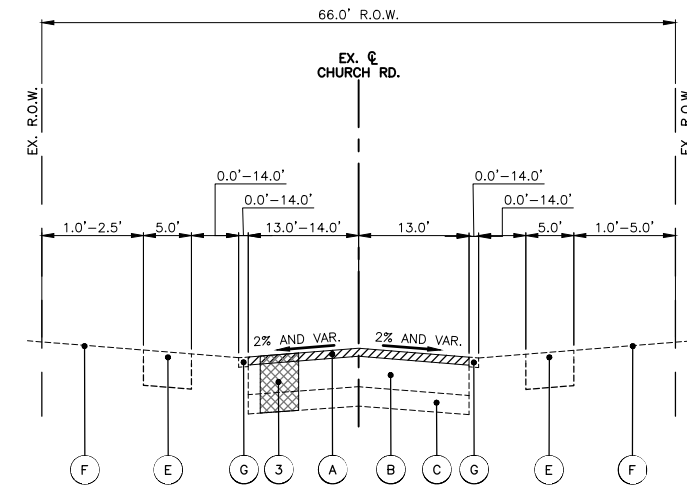

EXISTING TYPICAL SECTION - CHURCH RD.
STA: 16+53 - STA: 27+50

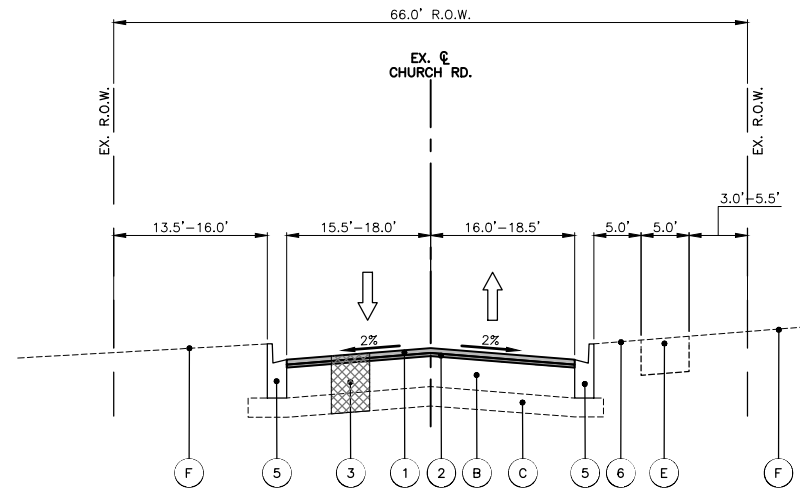

PROPOSED TYPICAL SECTION - CHURCH RD.
STA: 3+00 - STA: 16+53

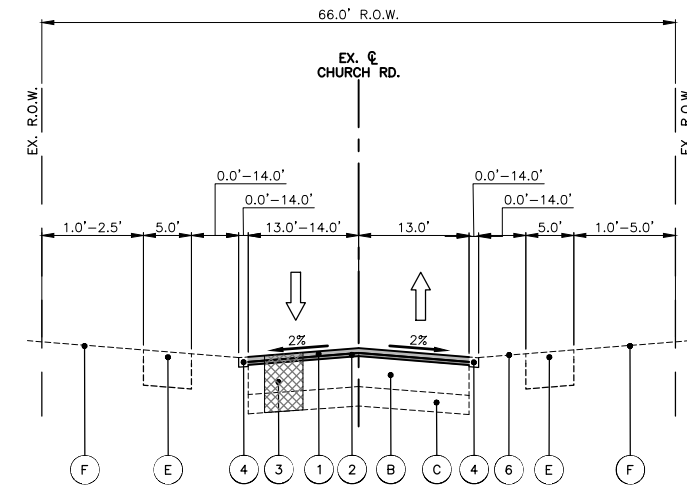

PROPOSED TYPICAL SECTION - CHURCH RD.
STA: 16+53 - STA: 27+50

EXISTING LEGEND

- A HOT-MIX ASPHALT SURFACE REMOVAL 3.0"
- B EXISTING PAVEMENT
- C AGGREGATE SUBBASE
- D COMBINATION CONCRETE CURB & GUTTER, VARIES FROM TYPE B-6.12 TO B-6.24
- E PORTLAND CEMENT CONCRETE SIDEWALK TO REMAIN IN PLACE
- F EXISTING GROUND
- G AGGREGATE SHOULDERS

HOT-MIX ASPHALT MIXTURE REQUIREMENTS

OPERATION	MIXTURE TYPE	AIR VOIDS @ NDES	QMP
PAVEMENT RESURFACING	HOT-MIX ASPHALT SURFACE COURSE, MIX "D", IL-9.5, N50, 2"	4% @ 50 GYR.	LR1030-2
	POLYMERIZED HOT-MIX ASPHALT BINDER COURSE, IL-4.75, N50, 1"	3.5% @ 50 GYR.	LR1030-2
CLASS D PATCHES	HOT-MIX ASPHALT BINDER COURSE, IL-19.0, N50, 8"	4% @ 50 GYR.	LR1030-2

QMP DESIGNATION: QUALITY CONTROL/QUALITY ASSURANCE (QC/QA) PER LR1030-2

THE UNIT WEIGHT USED TO CALCULATE ALL HMA SURFACE MIXTURE QUANTITIES IS 112 LBS/SQ YD/IN

THE "AC TYPE" FOR POLYMERIZED HMA MIXES SHALL BE "SBS/SBR PG 76-22" AND FOR NON-POLYMERIZED HMA THE "AC TYPE" SHALL BE "PG64-22" UNLESS MODIFIED BY RECLAIMED MATERIALS SPECIFICATIONS.

THE LONGITUDINAL JOINT SEALANT SHALL BE PLACED OVER THE P HMA BC IL-4.75 N50.

PROPOSED LEGEND

- 1 HOT-MIX ASPHALT SURFACE COURSE, MIX "D", IL-9.5, N50, 2"
- 2 POLYMERIZED HOT-MIX ASPHALT BINDER COURSE, IL-4.75, N50, 1"
- 3 CLASS D PATCHES W/SUBBASE GRANULAR MATERIAL, TYPE B, 8" (SPOT REMOVAL & REPLACEMENT AS DIRECTED BY THE ENGINEER)
- 4 AGGREGATE WEDGE SHOULDER, TYPE B, 1.5" AVERAGE THICKNESS
- 5 COMBINATION CONCRETE CURB & GUTTER, VARIES FROM TYPE B-6.12 TO B-6.24 (SPOT REMOVAL & REPLACEMENT AS DIRECTED BY THE ENGINEER)
- 6 TOPSOIL FURNISH AND PLACE, 4" AND SODDING, SALT TOLERANT (IN AREAS OF LANDSCAPE RESTORATION ONLY)

NOTES:

- THE PATCHING QUANTITIES HAVE BEEN ESTIMATED BASED ON FIELD OBSERVATIONS DURING DESIGN. ACTUAL QUANTITIES TO BE DETERMINED DURING CONSTRUCTION BY THE ENGINEER.
- NO PROPOSED WORK WILL TAKE PLACE OUTSIDE OF THE EXISTING R.O.W.
- STATION EQUATION: STA. 27+28.09 CHURCH RD = STA. 30+16.59 SHEFFER RD

COMPANY NAME: _____
 PROJECT CONTACT: _____
 DATE PLOTTED: 12/21/2023 12:57 PM
 CLIENT: Church-Typ Sections
 FILE NAME: Church-Typ Sections
 PLOT DRIVER: DWG To PDF.pc3
 PEN TABLE: ILDOT-Standard.ctb

USER NAME = HOPPM	DESIGNED - AN	REVISED -
FILE NAME = Church-Typ Sections	DRAWN - MH	REVISED -
PLOT SCALE = N.T.S.	CHECKED - TW	REVISED -
PLOT DATE = 12/21/2023	DATE - 09/18/2023	REVISED -

**STATE OF ILLINOIS
DEPARTMENT OF TRANSPORTATION**

**CHURCH ROAD
TYPICAL SECTIONS**

SCALE: N.T.S. SHEET NO. 01 OF 02 SHEETS STA. TO STA.

FAU RTE.	SECTION	COUNTY	TOTAL SHEETS	SHEET NO.
2513 1031	23-00363-00-RS	KANE	21	6
CONTRACT NO. 61K23				
ILLINOIS FED. AID PROJECT				

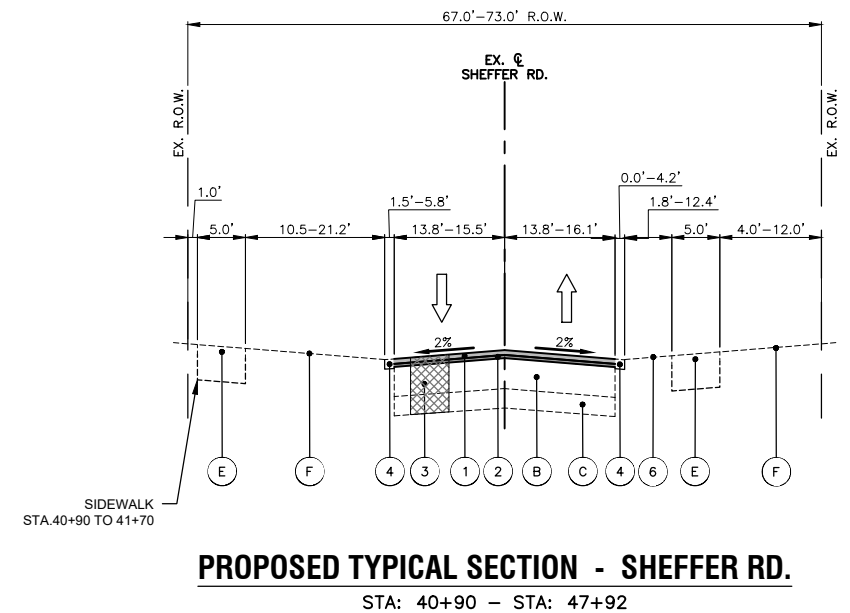
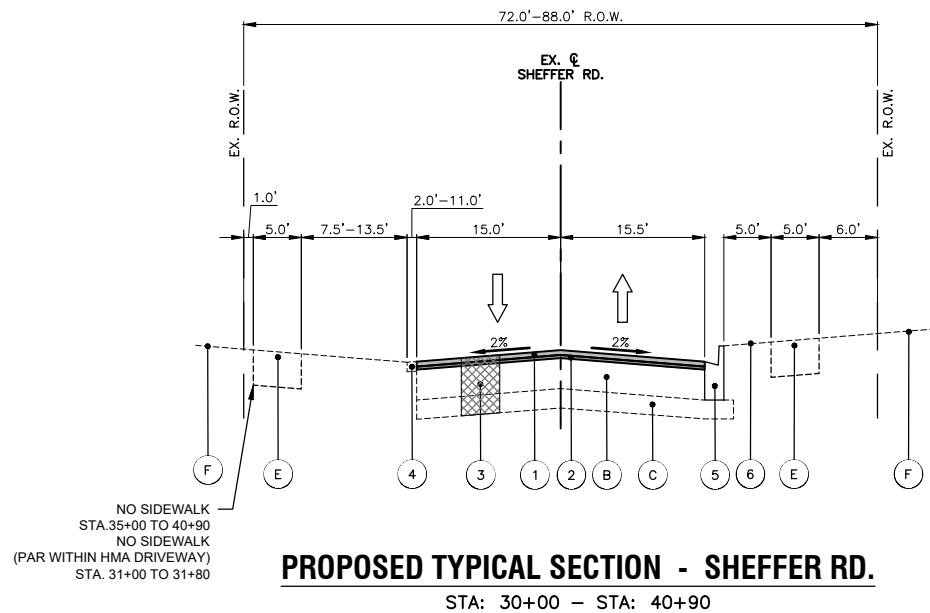
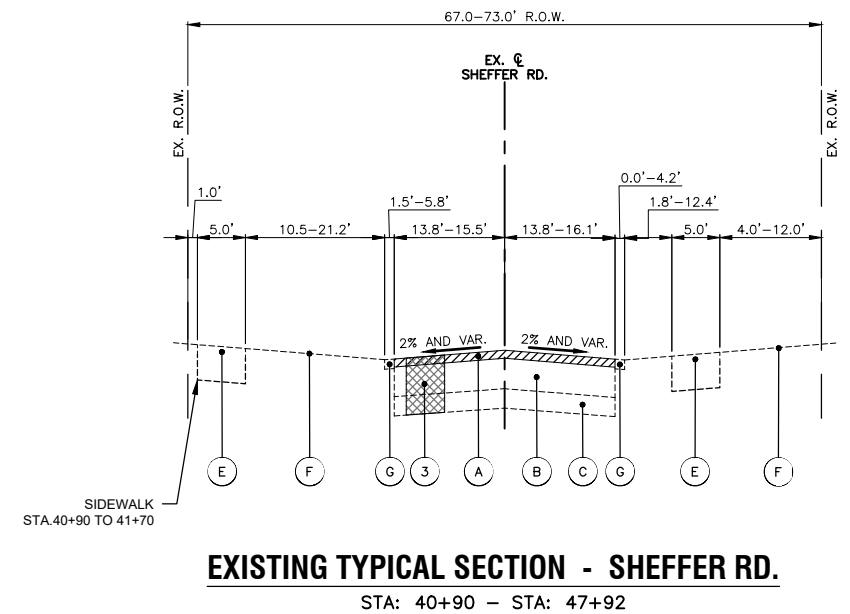
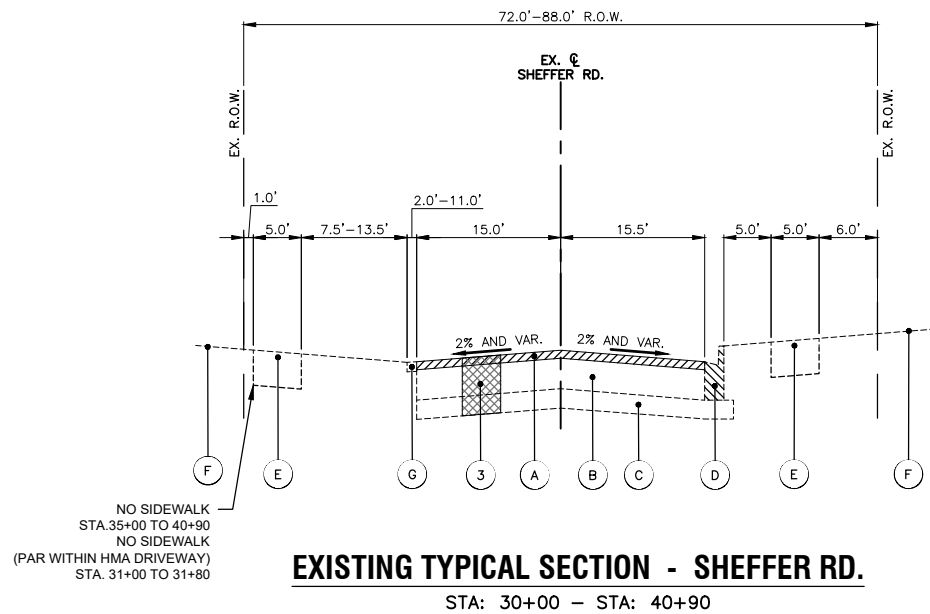

EXISTING LEGEND

- A HOT-MIX ASPHALT SURFACE REMOVAL 3.0"
- B EXISTING PAVEMENT
- C AGGREGATE SUBBASE
- D COMBINATION CONCRETE CURB & GUTTER, VARIES FROM TYPE B-6.12 TO B-6.24
- E PORTLAND CEMENT CONCRETE SIDEWALK TO REMAIN IN PLACE
- F EXISTING GROUND
- G AGGREGATE SHOULDERS

PROPOSED LEGEND

- 1 HOT-MIX ASPHALT SURFACE COURSE, MIX "D", IL-9.5, N50, 2"
- 2 POLYMERIZED HOT-MIX ASPHALT BINDER COURSE, IL-4.75, N50, 1"
- 3 CLASS D PATCHES W/SUBBASE GRANULAR MATERIAL, TYPE B, 8" (SPOT REMOVAL & REPLACEMENT AS DIRECTED BY THE ENGINEER)
- 4 AGGREGATE WEDGE SHOULDER, TYPE B, 1.5" AVERAGE THICKNESS
- 5 COMBINATION CONCRETE CURB & GUTTER, VARIES FROM TYPE B-6.12 TO B-6.24 (SPOT REMOVAL & REPLACEMENT AS DIRECTED BY THE ENGINEER)
- 6 TOPSOIL FURNISH AND PLACE, 4" AND SODDING, SALT TOLERANT (IN AREAS OF LANDSCAPE RESTORATION ONLY)

NOTES:

- THE PATCHING QUANTITIES HAVE BEEN ESTIMATED BASED ON FIELD OBSERVATIONS DURING DESIGN. ACTUAL QUANTITIES TO BE DETERMINED DURING CONSTRUCTION BY THE ENGINEER.
- NO PROPOSED WORK WILL TAKE PLACE OUTSIDE OF THE EXISTING R.O.W.
- STATION EQUATION: STA. 27+28.09 CHURCH RD = STA. 30+16.59 SHEFFER RD

COMPANY NAME: _____
 PROJECT CONTACT: _____
 DATE PLOTTED: 12/21/2023 12:57 PM
 CLIENT: Church-Typ Sections
 FILE NAME: Church-Typ Sections
 PLOT DRIVER: DWG To PDF.pc3
 PEN TABLE: ILDOT-Standard.ctb

USER NAME = HOPPM	DESIGNED - AN	REVISED -
FILE NAME = Church-Typ Sections	DRAWN - MH	REVISED -
PLOT SCALE = N.T.S.	CHECKED - TW	REVISED -
PLOT DATE = 12/21/2023	DATE - 09/18/2023	REVISED -

**STATE OF ILLINOIS
DEPARTMENT OF TRANSPORTATION**

**SHEFFER ROAD
TYPICAL SECTIONS**

SCALE: N.T.S. SHEET NO. 02 OF 02 SHEETS STA. TO STA.

FAU RTE.	SECTION	COUNTY	TOTAL SHEETS	SHEET NO.
2513 1031	23-00363-00-RS	KANE	21	7
CONTRACT NO. 61K23				
ILLINOIS FED. AID PROJECT				

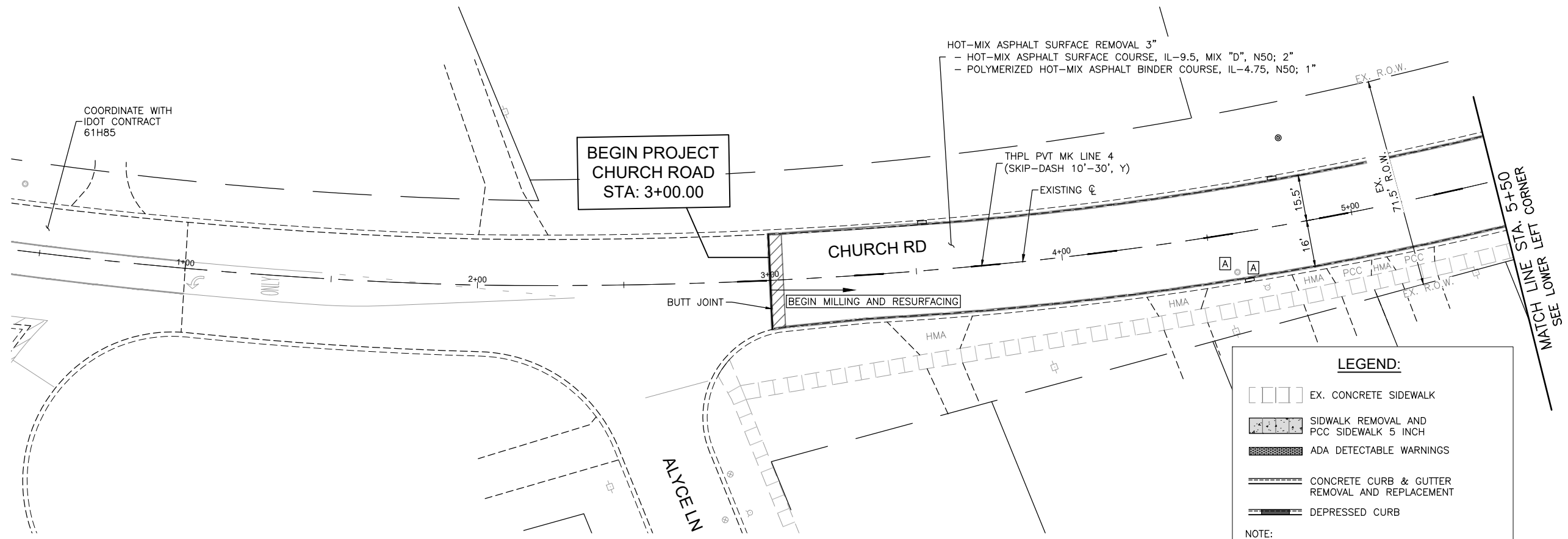

LEGEND:

- EX. CONCRETE SIDEWALK
- SIDEWALK REMOVAL AND PCC SIDEWALK 5 INCH
- ADA DETECTABLE WARNINGS
- CONCRETE CURB & GUTTER REMOVAL AND REPLACEMENT
- DEPRESSED CURB

NOTE:
 ANY SOILS GENERATED FROM CURB AND SIDEWALK REPAIRS SHALL REMAIN ON SITE IN THE RIGHT-OF-WAY. ANY SUCH SOIL SHALL BE PLACED AROUND LANDSCAPED RADIUS RETURNS OR WITHIN LANDSCAPED DITCH AREAS AS DIRECTED BY THE ENGINEER AND RESTORED.

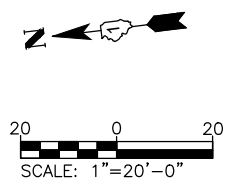
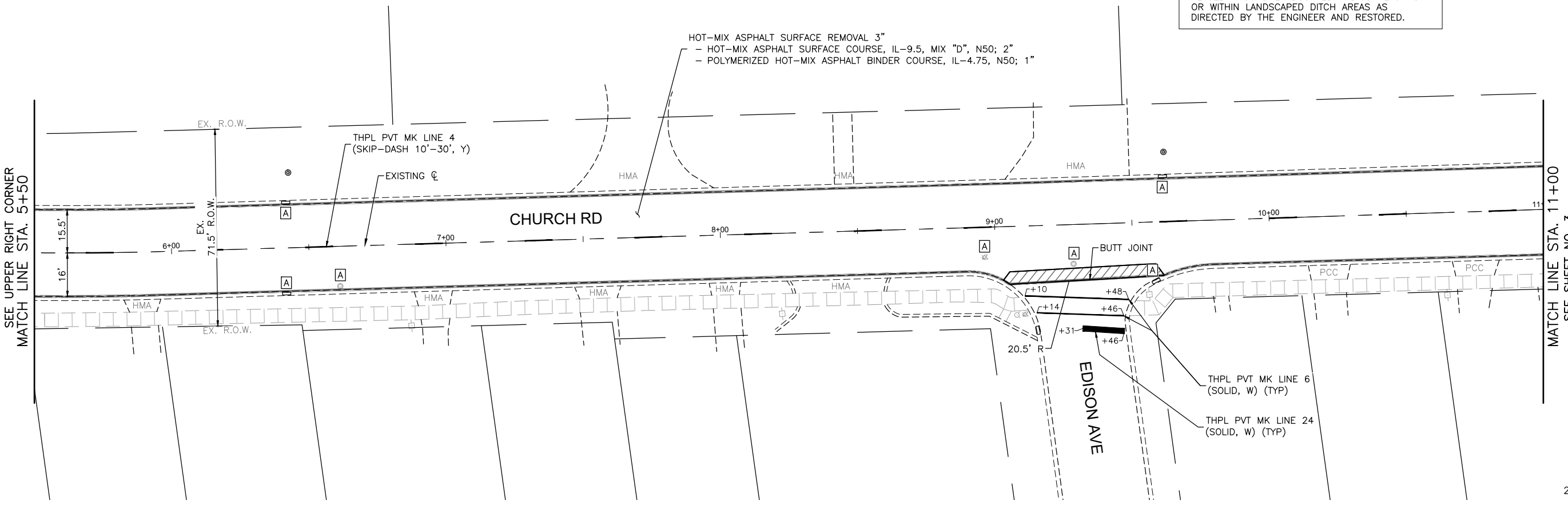
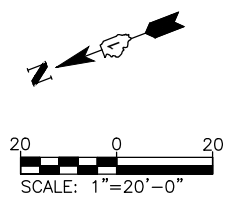

COMPANY NAME:
 PROJECT CONTACT:
 DATE PLOTTED: 12/21/2023 12:58 PM
 CLIENT: Church-Resurf-Plan_Ph2
 FILE NAME: Church-Resurf-Plan_Ph2
 PLOT DRIVER: DWG To PDF.pc3
 PEN TABLE: ILDOT-Standard.ctb

USER NAME = HOPPM	DESIGNED - AN	REVISED -
FILE NAME = Church-Resurf-Plan_Ph2	DRAWN - MH	REVISED -
PLOT SCALE = 1"=20'	CHECKED - TW	REVISED -
PLOT DATE = 12/21/2023	DATE - 09/18/2023	REVISED -

**STATE OF ILLINOIS
DEPARTMENT OF TRANSPORTATION**

**CHURCH ROAD
RESURFACING AND PAVEMENT MARKING PLAN**

SCALE: 1"=20' SHEET NO. 1 OF 5 SHEETS STA. 1+00 TO STA. 11+00

FAU RTE.	SECTION	COUNTY	TOTAL SHEETS	SHEET NO.
2513 1031	23-00363-00-RS	KANE	21	8
CONTRACT NO. 61K23				
ILLINOIS FED. AID PROJECT				

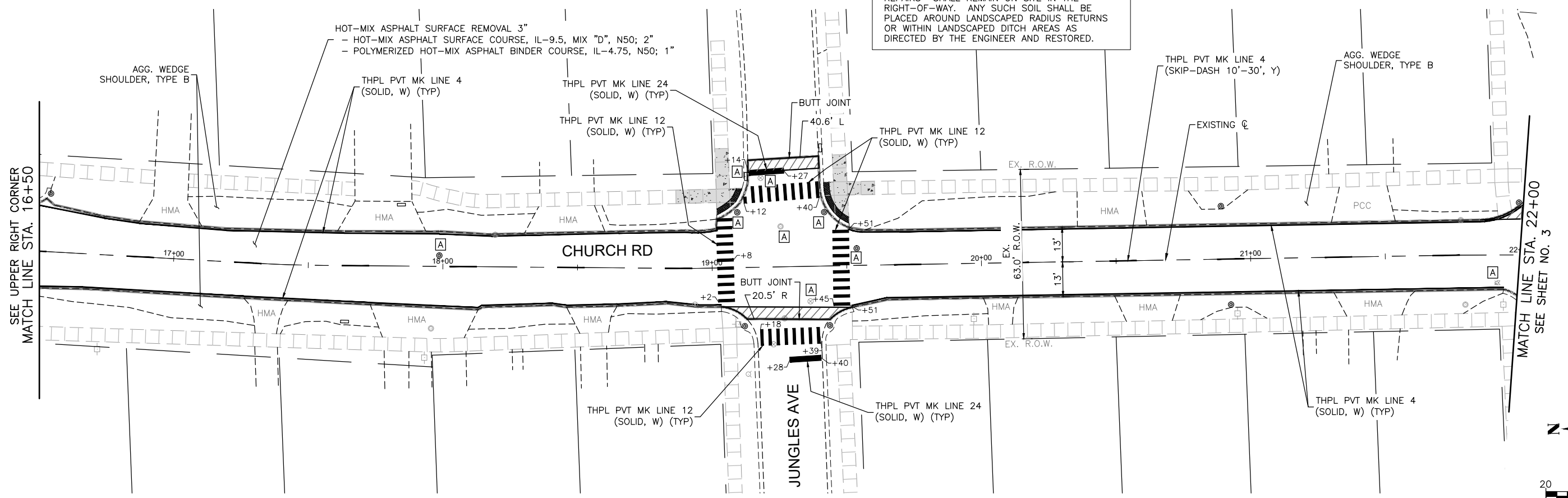
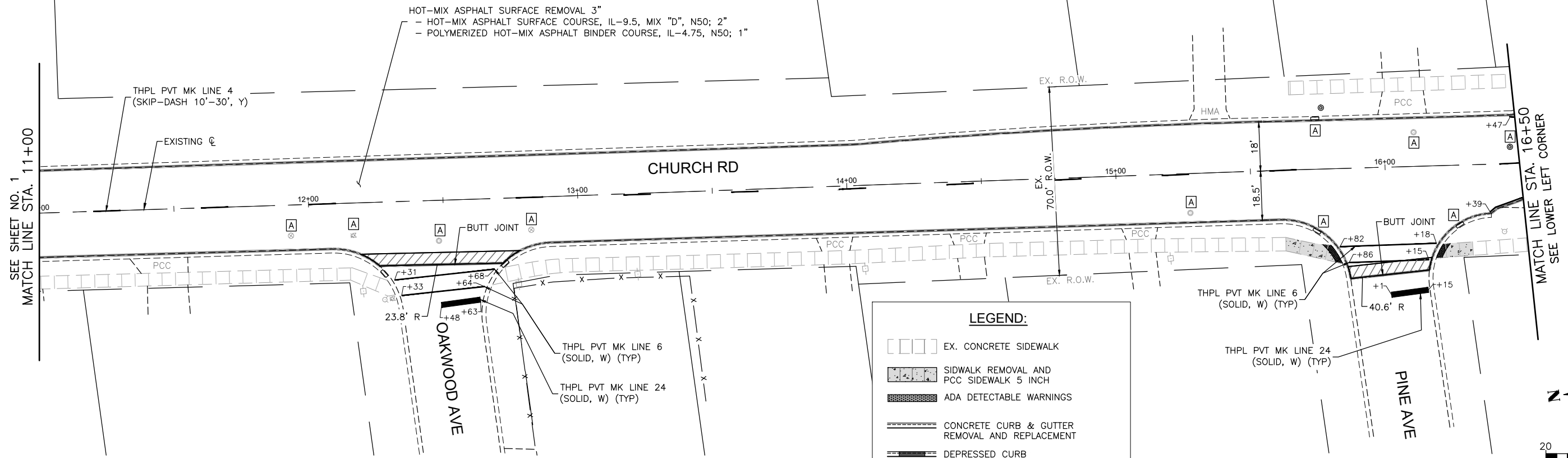

LEGEND:

- EX. CONCRETE SIDEWALK
- SIDEWALK REMOVAL AND PCC SIDEWALK 5 INCH
- ADA DETECTABLE WARNINGS
- CONCRETE CURB & GUTTER REMOVAL AND REPLACEMENT
- DEPRESSED CURB

NOTE:
 ANY SOILS GENERATED FROM CURB AND SIDEWALK REPAIRS SHALL REMAIN ON SITE IN THE RIGHT-OF-WAY. ANY SUCH SOIL SHALL BE PLACED AROUND LANDSCAPED RADIUS RETURNS OR WITHIN LANDSCAPED DITCH AREAS AS DIRECTED BY THE ENGINEER AND RESTORED.

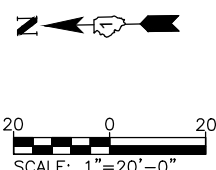
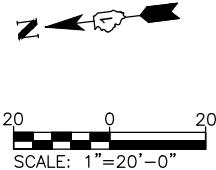

COMPANY NAME:
 PROJECT CONTACT:
 DATE PLOTTED: 12/21/2023 12:58 PM
 CLIENT: Church-Resurf-Plan_Ph2
 FILE NAME: Church-Resurf-Plan_Ph2
 PLOT DRIVER: DWG To PDF.pc3
 PEN TABLE: ILDOT-Standard.ctb

USER NAME = HOPPM	DESIGNED - AN	REVISED -
FILE NAME = Church-Resurf-Plan_Ph2	DRAWN - MH	REVISED -
PLOT SCALE = 1"=20'	CHECKED - TW	REVISED -
PLOT DATE = 12/21/2023	DATE - 09/18/2023	REVISED -

STATE OF ILLINOIS
DEPARTMENT OF TRANSPORTATION

CHURCH ROAD
RESURFACING AND PAVEMENT MARKING PLAN

SCALE: 1"=20' SHEET NO. 2 OF 5 SHEETS STA. 11+00 TO STA. 22+00

FAU RTE.	SECTION	COUNTY	TOTAL SHEETS	SHEET NO.
2513 1031	23-00363-00-RS	KANE	21	9
CONTRACT NO. 61K23				
ILLINOIS FED. AID PROJECT				

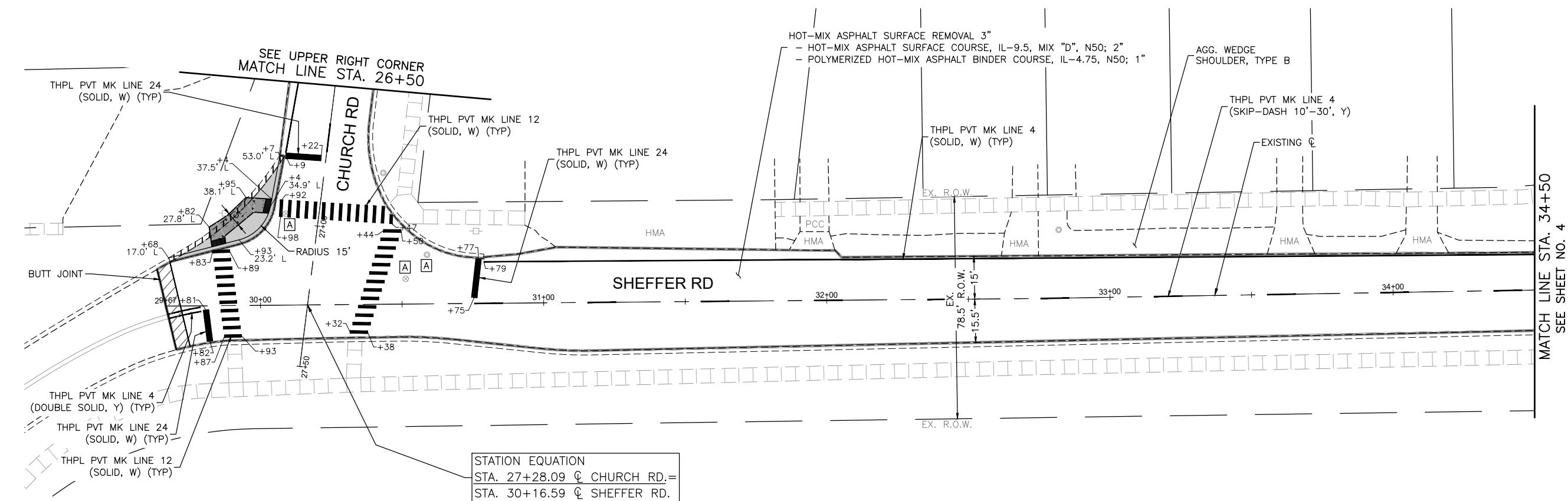
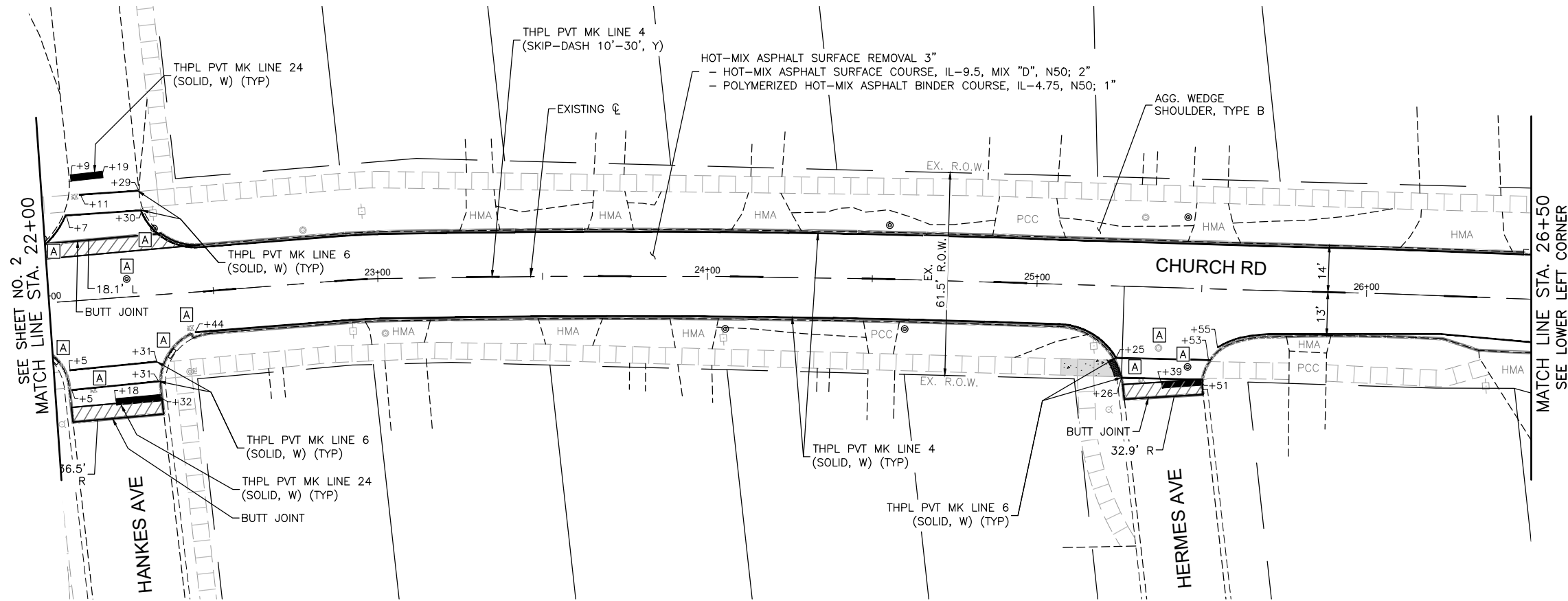

COMPANY NAME: ILLINOIS DEPARTMENT OF TRANSPORTATION
 PROJECT CONTACT: CHURCH ROAD AND SHEFFER ROAD RESURFACING AND PAVEMENT MARKING PLAN
 DATE PLOTTED: 12/21/2023 12:58 PM
 CLIENT: Church-Resurf-Plan_Ph2
 FILE NAME: Church-Resurf-Plan_Ph2
 PLOT DRIVER: DWG To PDF.pc3
 PEN TABLE: ILLDOT-Standard.ctb

USER NAME = HOPPM	DESIGNED - AN	REVISED -
FILE NAME = Church-Resurf-Plan_Ph2	DRAWN - MH	REVISED -
PLOT SCALE = 1"=20'	CHECKED - TW	REVISED -
PLOT DATE = 12/21/2023	DATE - 09/18/2023	REVISED -

STATE OF ILLINOIS
DEPARTMENT OF TRANSPORTATION

CHURCH ROAD AND SHEFFER ROAD
RESURFACING AND PAVEMENT MARKING PLAN
 SCALE: 1"=20' SHEET NO. 3 OF 5 SHEETS STA. 22+00 TO STA. 34+50

FAU RTE. 2513 1031	SECTION 23-00363-00-RS	COUNTY KANE	TOTAL SHEETS 21	SHEET NO. 10
CONTRACT NO. 61K23				
ILLINOIS FED. AID PROJECT				

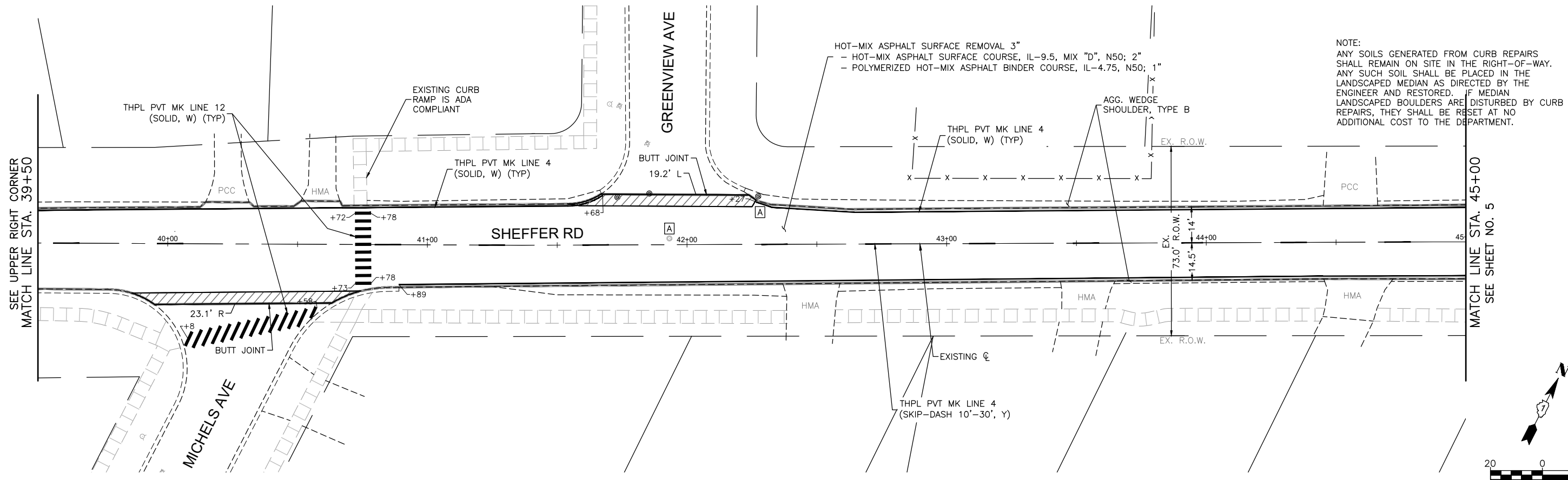
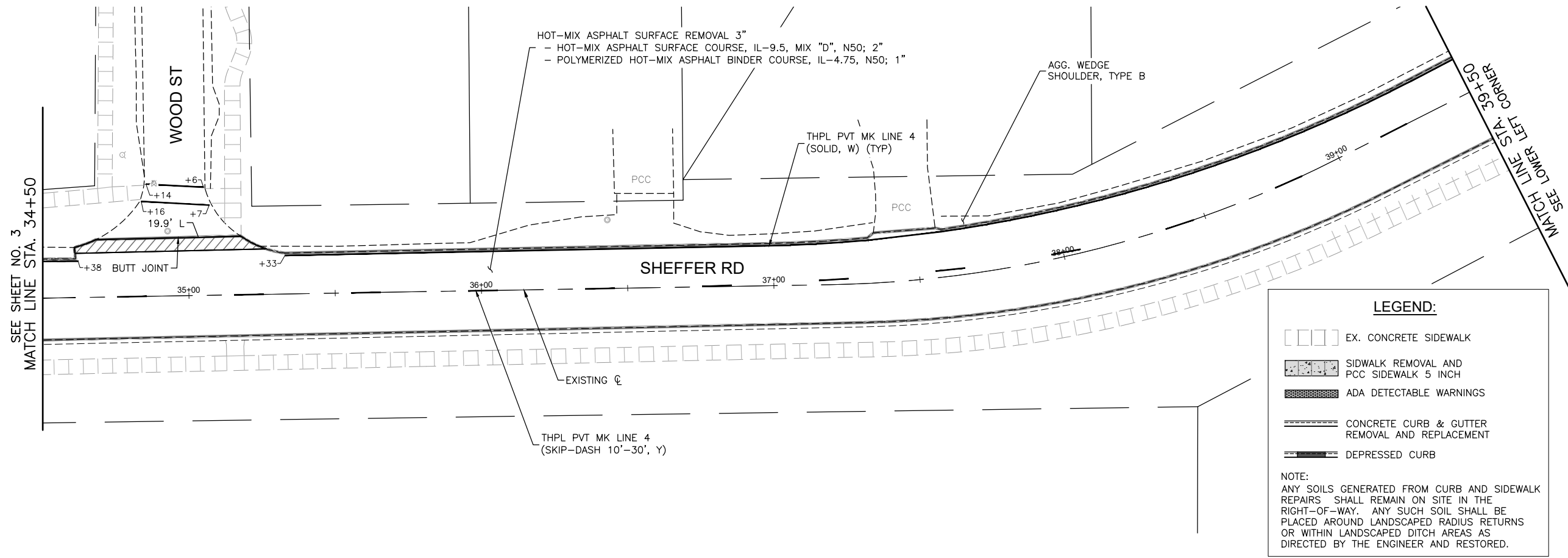

COMPANY NAME: Church-Resurf-Plan_Ph2
 PROJECT CONTACT: Church-Resurf-Plan_Ph2
 DATE PLOTTED: 12/21/2023 12:58 PM
 FILE NAME: Church-Resurf-Plan_Ph2
 PLOT DRIVER: DWG To PDF.pc3
 PEN TABLE: ILDOT-Standard.ctb

USER NAME = HOPPM	DESIGNED - AN	REVISED -
FILE NAME = Church-Resurf-Plan_Ph2	DRAWN - MH	REVISED -
PLOT SCALE = 1"=20'	CHECKED - TW	REVISED -
PLOT DATE = 12/21/2023	DATE - 09/18/2023	REVISED -

STATE OF ILLINOIS
DEPARTMENT OF TRANSPORTATION

SHEFFER ROAD RESURFACING AND PAVEMENT MARKING PLAN		
SCALE: 1"=20'	SHEET NO. 4 OF 5 SHEETS	STA. 34+50 TO STA. 45+00

FAU RTE. 2513 1031	SECTION 23-00363-00-RS	COUNTY KANE	TOTAL SHEETS 21	SHEET NO. 11
CONTRACT NO. 61K23				
ILLINOIS FED. AID PROJECT				

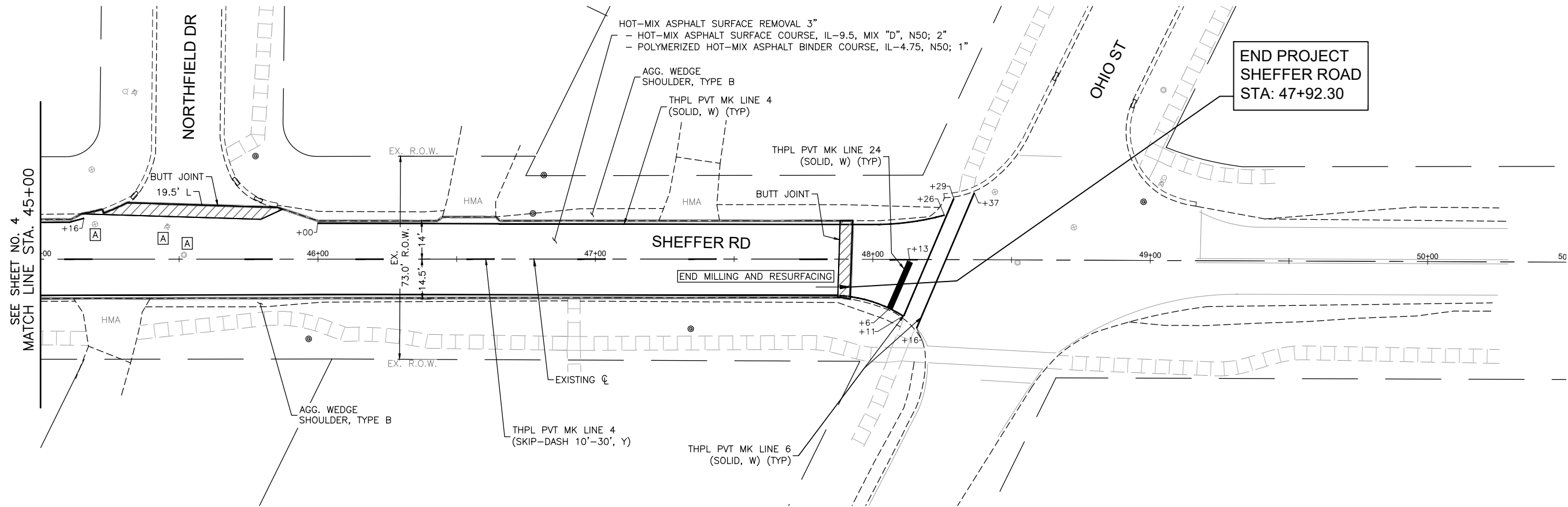

SEE SHEET NO. 4
MATCH LINE STA. 45+00

END PROJECT
SHEFFER ROAD
STA: 47+92.30

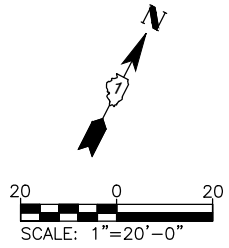

LEGEND:

- EX. CONCRETE SIDEWALK
- SIDEWALK REMOVAL AND PCC SIDEWALK 5 INCH
- ADA DETECTABLE WARNINGS
- CONCRETE CURB & GUTTER REMOVAL AND REPLACEMENT
- DEPRESSED CURB

NOTE:
ANY SOILS GENERATED FROM CURB AND SIDEWALK REPAIRS SHALL REMAIN ON SITE IN THE RIGHT-OF-WAY. ANY SUCH SOIL SHALL BE PLACED AROUND LANDSCAPED RADIUS RETURNS OR WITHIN LANDSCAPED DITCH AREAS AS DIRECTED BY THE ENGINEER AND RESTORED.

COMPANY NAME: ILLINOIS
PROJECT CONTACT:
DATE PLOTTED: 12/21/2023 12:58 PM
CLIENT: Church-Resurf-Plan_Ph2
FILE NAME: Church-Resurf-Plan_Ph2
PLOT DRIVER: DWG To PDF.pc3
PEN TABLE: ILDOT-Standard.ctb

USER NAME = HOPPM	DESIGNED - AN	REVISED -
FILE NAME = Church-Resurf-Plan_Ph2	DRAWN - MH	REVISED -
PLOT SCALE = 1"=20'	CHECKED - TW	REVISED -
PLOT DATE = 12/21/2023	DATE - 09/18/2023	REVISED -

**STATE OF ILLINOIS
DEPARTMENT OF TRANSPORTATION**

**SHEFFER BLVD
RESURFACING AND PAVEMENT MARKING PLAN**

SCALE: 1"=20' SHEET NO. 5 OF 5 SHEETS STA. 45+00 TO STA. 47+92

FAU RTE. 2513 1031	SECTION 23-00363-00-RS	COUNTY KANE	TOTAL SHEETS 21	SHEET NO. 12
CONTRACT NO. 61K23				
ILLINOIS FED. AID PROJECT				

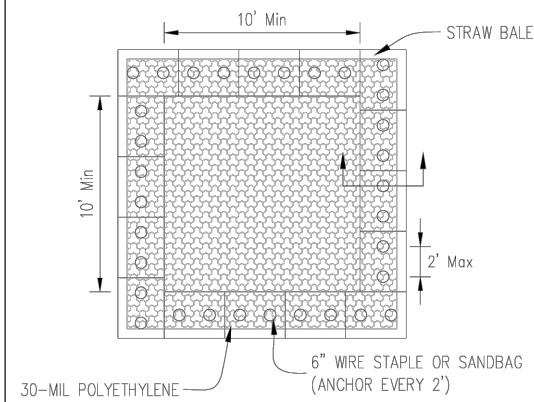

PLAN VIEW

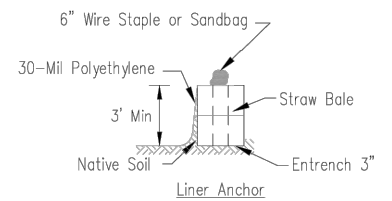

STRAW BALE ANCHOR SECTIONS

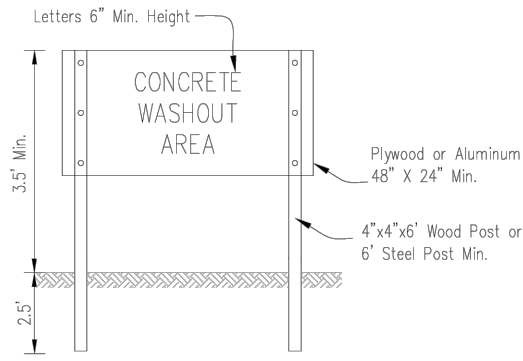

SIGN DETAIL

NOTES:

- Maintaining temporary concrete washout facilities shall include removing and disposing of hardened concrete and/or slurry and returning the facilities to a functional condition.
- Facility shall be cleaned or reconstructed in a new area once washout becomes two-thirds full.
- Each straw bale is to be staked in place using (2) 2"x2"x4" wooden stakes.

INLET PROTECTION - PAVED AREAS
CURB PROTECTION

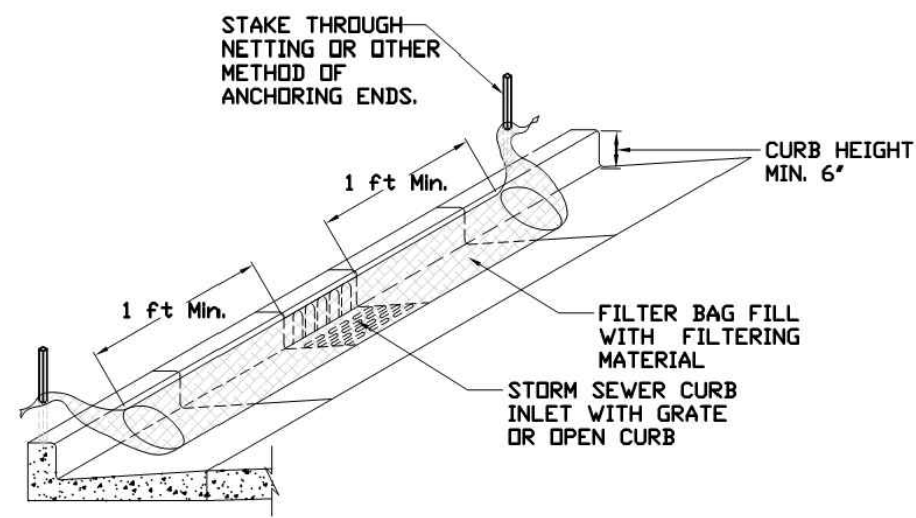

INLET PROTECTION - PAVED AREAS
DROP-IN PROTECTION

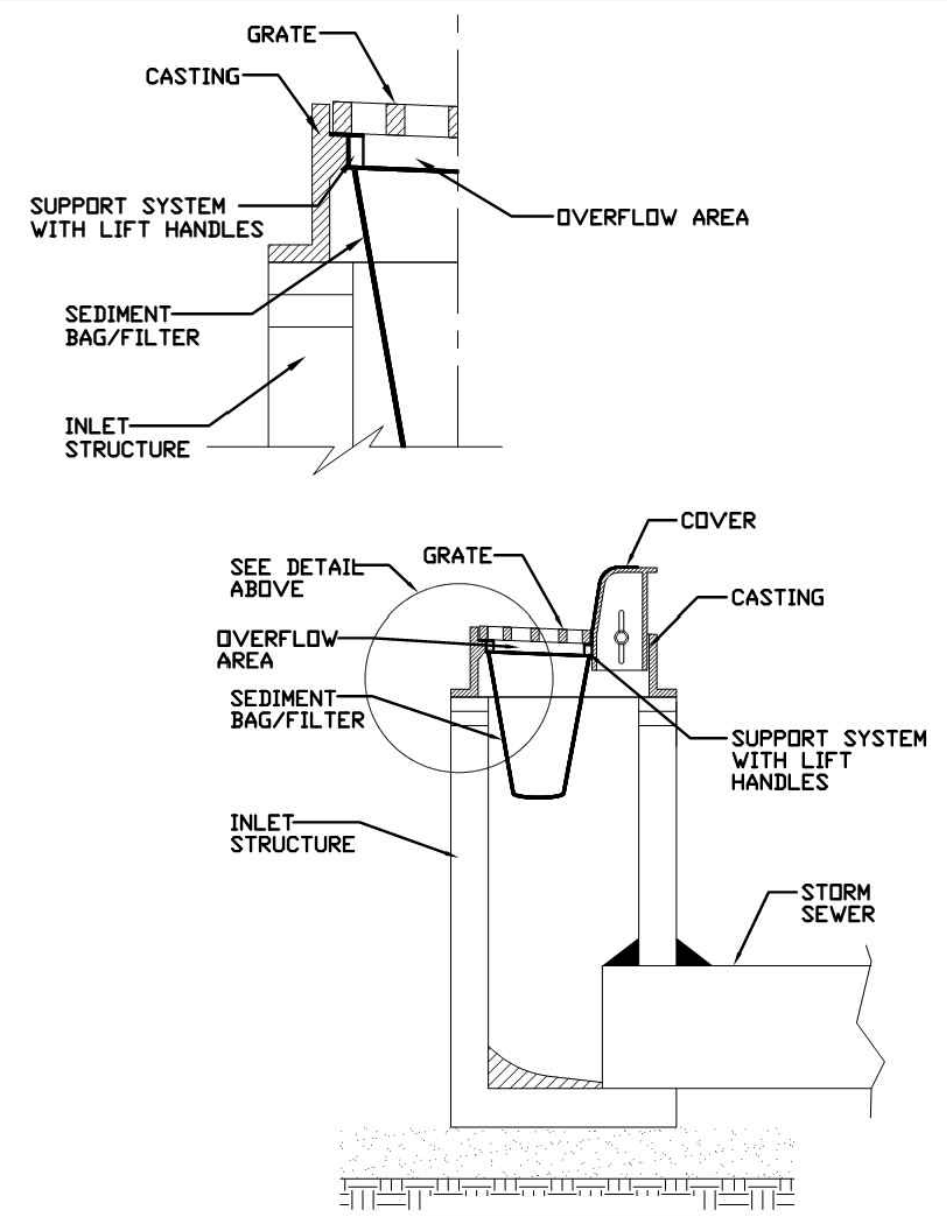

COMPANY NAME: _____ PROJECT CONTACT: _____ CLIENT: _____ DATE PLOTTED: 12/21/2023 12:58 PM FILE NAME: Church-Details PLOT DRIVER: DWG To PDF.pc3 PEN TABLE: SEC-Standard.ctb	DESIGNED: _____ DRAWN: B. JOHNSON CHECKED: _____ APPROVED: _____	DATE: 6/08
--	---	------------

TEMPORARY CONCRETE
WASHOUT FACILITY - STRAW BALE

REFERENCE Project _____ Designed _____ Checked _____ Approved _____	DATE: _____ DATE: _____ DATE: _____ DATE: _____
---	--



STANDARD DWG. NO.
IUM-561C
SHEET 1 OF 1
DATE 01-11-11



REFERENCE Project _____ Designed _____ Checked _____ Approved _____	DATE: _____ DATE: _____ DATE: _____ DATE: _____
---	--

STANDARD DWG. NO.
IUM-561D
SHEET 1 OF 1
DATE 01-11-11

COMPANY NAME: _____
PROJECT CONTACT: _____
CLIENT: _____
DATE PLOTTED: 12/21/2023 12:58 PM
FILE NAME: Church-Details
PLOT DRIVER: DWG To PDF.pc3
PEN TABLE: SEC-Standard.ctb

USER NAME = HOPPM	DESIGNED - AN	REVISED -
FILE NAME = Church-Details	DRAWN - MH	REVISED -
PLOT SCALE = N.T.S.	CHECKED - TW	REVISED -
PLOT DATE = 12/21/2023	DATE - 09/18/2023	REVISED -

STATE OF ILLINOIS
DEPARTMENT OF TRANSPORTATION

EROSION CONTROL DETAILS

SCALE: N.T.S. SHEET NO. 01 OF 01 SHEETS STA. TO STA.

FAU RTE.	SECTION	COUNTY	TOTAL SHEETS	SHEET NO.
2513 1031	23-00363-00-RS	KANE	21	13
CONTRACT NO. 61K23				
ILLINOIS FED. AID PROJECT				

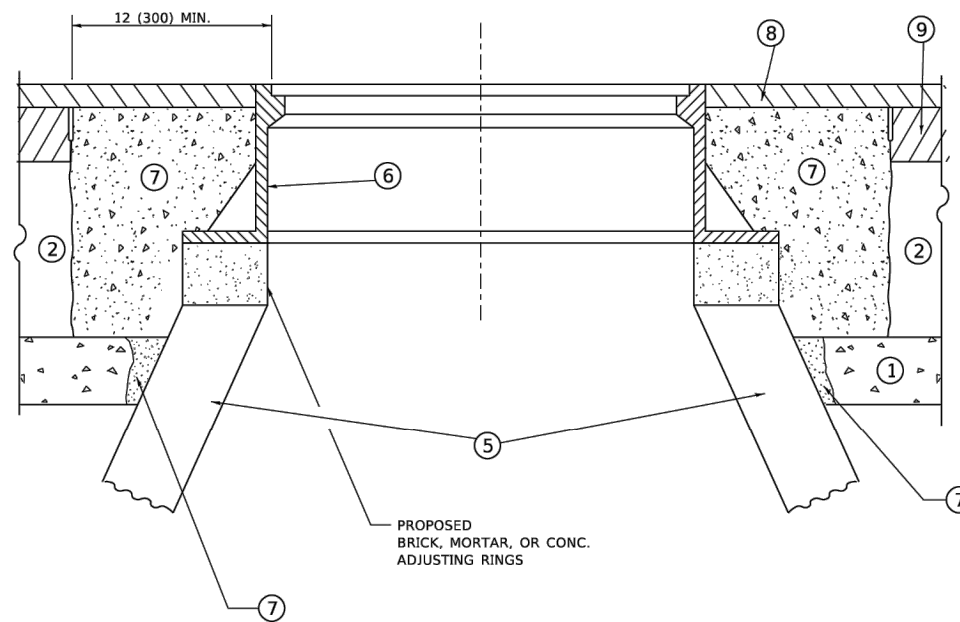
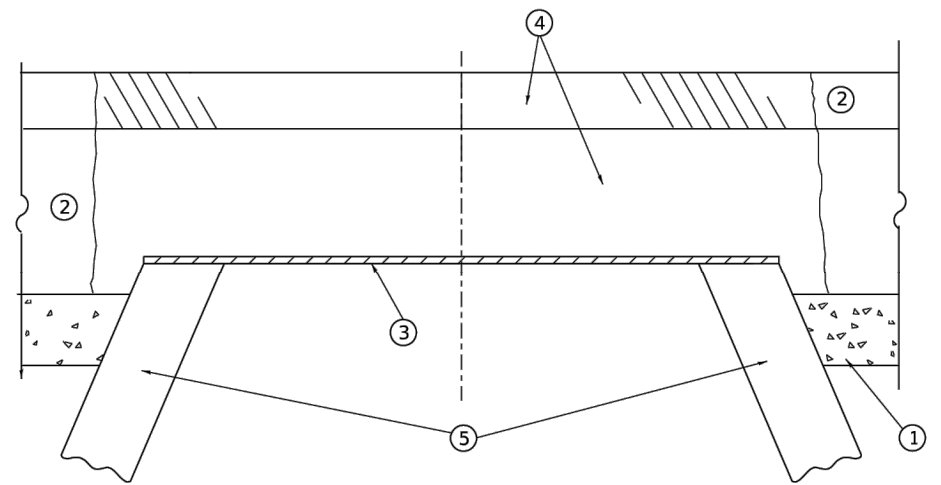

**DETAILS FOR FRAMES AND LIDS ADJUSTMENT
WITH MILLING**

NOTES

1. EXISTING BROKEN FRAMES AND LIDS SHALL BE REMOVED AND DISPOSED OF BY THE CONTRACTOR AND SHALL BE REPLACED AS DIRECTED BY THE ENGINEER. REPLACEMENT FRAMES AND LIDS WILL BE PAID FOR IN ACCORDANCE WITH ARTICLE 109.04 OF THE STANDARD SPECIFICATIONS UNLESS A SEPARATE PAY ITEM HAS BEEN PROVIDED.
2. IF THE EXISTING LIDS ARE OPEN, THE FRAME WILL BE ADJUSTED TO THE ELEVATION OF THE MILLED PAVEMENT SURFACE PRIOR TO THE MILLING OPERATION. THE FRAME WILL NOT BE REMOVED AND COVERED BY THE METAL PLATE.
3. CITY OF CHICAGO CASTINGS ARE THE PROPERTY OF THE CITY AND THE CONTRACTOR SHALL NOTIFY THE CITY FOR REMOVAL AND DISPOSITION OF THE CASTINGS.
4. THE METAL PLATE USED TO COVER THE STRUCTURE SHALL REMAIN THE PROPERTY OF THE CONTRACTOR.
5. THE CONTRACTOR SHALL REMOVE ALL TRAFFIC CONTROL DEVICES BY THE END OF EACH WORK SHIFT.

CONSTRUCTION PROCEDURES

STAGE 1 (BEFORE PAVEMENT MILLING)

- A) REMOVE A MINIMUM OF 12 (300) OF THE PAVEMENT FROM AROUND THE STRUCTURE.
- B) REMOVE THE EXISTING FRAME AND LID FROM THE STRUCTURE.
- C) COVER THE STRUCTURE OPENING WITH A 36 (900) DIAMETER METAL PLATE.
- D) BACKFILL WITH CRUSHED STONE AND HMA SURFACE MIX APPROVED BY THE ENGINEER. (MIN. 3 (80) HMA TO REMAIN AFTER MILLING).

STAGE 2 (AFTER PAVEMENT MILLING)

- A) REMOVE THE HMA SURFACE MIX AND CRUSHED STONE.
- B) INSTALL THE FRAME AND LID; ADJUST THE FRAME TO ITS FINAL SURFACE ELEVATION.
- C) THE SURROUNDING SPACE SHALL BE FILLED WITH CLASS PP-2* CONCRETE TO THE ELEVATION OF THE SURFACE OF THE EXISTING BASE COURSE OR THE BINDER COURSE.

* UNLESS OTHERWISE SPECIFIED IN THE PLANS.

THE PROCEDURE EXPLAINED ABOVE SHALL CONFORM TO THE APPLICABLE PORTIONS OF SECTIONS 353, 406, 602, AND 603 OF THE STANDARD SPECIFICATIONS EXCEPT THAT "THE CONTRACTOR SHALL ADJUST THE STRUCTURES TO THE FINISHED PAVEMENT ELEVATION NO MORE THAN 5 CALENDAR DAYS PRIOR TO PLACEMENT OF THE FINAL LIFT OF SURFACE UNLESS APPROVED BY THE ENGINEER."

LEGEND

- | | |
|--|-------------------------------|
| ① SUB-BASE GRANULAR MATERIAL | ⑥ FRAME AND LID (SEE NOTES) |
| ② EXISTING PAVEMENT | ⑦ CLASS PP-2* CONCRETE |
| ③ 36 (900) DIAMETER METAL PLATE | ⑧ PROPOSED HMA SURFACE COURSE |
| ④ PROPOSED CRUSHED STONE AND HMA SURFACE MIX | ⑨ PROPOSED HMA BINDER COURSE |
| ⑤ EXISTING STRUCTURE | |

LOCATION OF STRUCTURES

THE CONTRACTOR WILL BE REQUIRED TO KEEP A RECORD OF THE LOCATIONS OF THE BURIED STRUCTURES ACCORDING TO THE STATION AND DISTANCE LEFT OR RIGHT OF THE CENTERLINE OF PAVEMENT. UPON COMPLETION OF THE WORK, THE CONTRACTOR WILL DELIVER THE RECORD TO THE ENGINEER.

BASIS OF PAYMENT

1. REMOVING FRAMES AND LIDS ON DRAINAGE AND UTILITY STRUCTURES IN THE PAVEMENT PRIOR TO MILLING, AND ADJUSTING TO FINAL GRADE PRIOR TO PLACING THE SURFACE COURSE, WILL BE PAID FOR AT THE CONTRACT UNIT PRICE EACH FOR "FRAMES AND LIDS TO BE ADJUSTED (SPECIAL)."
2. THIS WORK WILL NOT BE PAID FOR WHEN DRAINAGE AND UTILITY STRUCTURES ARE SPECIFIED FOR PAYMENT AS STRUCTURE RECONSTRUCTION.
3. NEW FRAMES AND LIDS, WHEN SPECIFIED, WILL BE PAID FOR SEPARATELY.
4. WHEN STRUCTURES ARE TO BE ADJUSTED OR RECONSTRUCTED, THE LOWERING AND RAISING OF THE FRAMES AND LIDS WILL NOT BE PAID FOR SEPARATELY BUT WILL BE INCLUDED IN THE COST OF THE CORRESPONDING PAY ITEM.

ALL DIMENSIONS ARE IN INCHES (MILLIMETERS) UNLESS OTHERWISE SHOWN

**STATE OF ILLINOIS
DEPARTMENT OF TRANSPORTATION**

**DETAILS FOR
FRAMES AND LIDS ADJUSTMENT WITH MILLING**

USER NAME = Lawrence.DeManche	DESIGNED - R. SHAH	REVISED - R. BORO 03-09-11
	DRAWN -	REVISED - R. BORO 12-06-11
PLOT SCALE = 100.0000' / in.	CHECKED -	REVISED - K. SMITH 11-18-22
PLOT DATE = 9/15/2023	DATE - 10-25-94	REVISED - K. SMITH 09-15-23

SCALE: NONE SHEET 1 OF 1 SHEETS STA. TO STA.

F.A. RTE.	SECTION	COUNTY	TOTAL SHEETS	SHEET NO.
2513 1031	23-00363-00-RS	KANE	21	14
BD600-03 (BD-08)			CONTRACT NO. 61K23	
ILLINOIS FED. AID PROJECT				

METHOD OF MEASUREMENT

REFER TO SECTION 442 OF THE STANDARD SPECIFICATIONS FOR ROAD AND BRIDGE CONSTRUCTION AND THE RECURRING SPECIAL PROVISION "PATCHING WITH HOT-MIX ASPHALT OVERLAY REMOVAL."

BASIS OF PAYMENT

1. REFER TO SECTION 442 OF THE STANDARD SPECIFICATIONS FOR ROAD AND BRIDGE CONSTRUCTION AND THE RECURRING SPECIAL PROVISION "PATCHING WITH HOT-MIX ASPHALT OVERLAY REMOVAL."
2. SAW CUT/SCORING OF EXISTING HMA OVERLAY IS INCLUDED IN THE COST OF PAVEMENT PATCHING.
3. SAW CUT/SCORING OF EXISTING PAVEMENT IS INCLUDED IN THE COST OF PAVEMENT PATCHING.

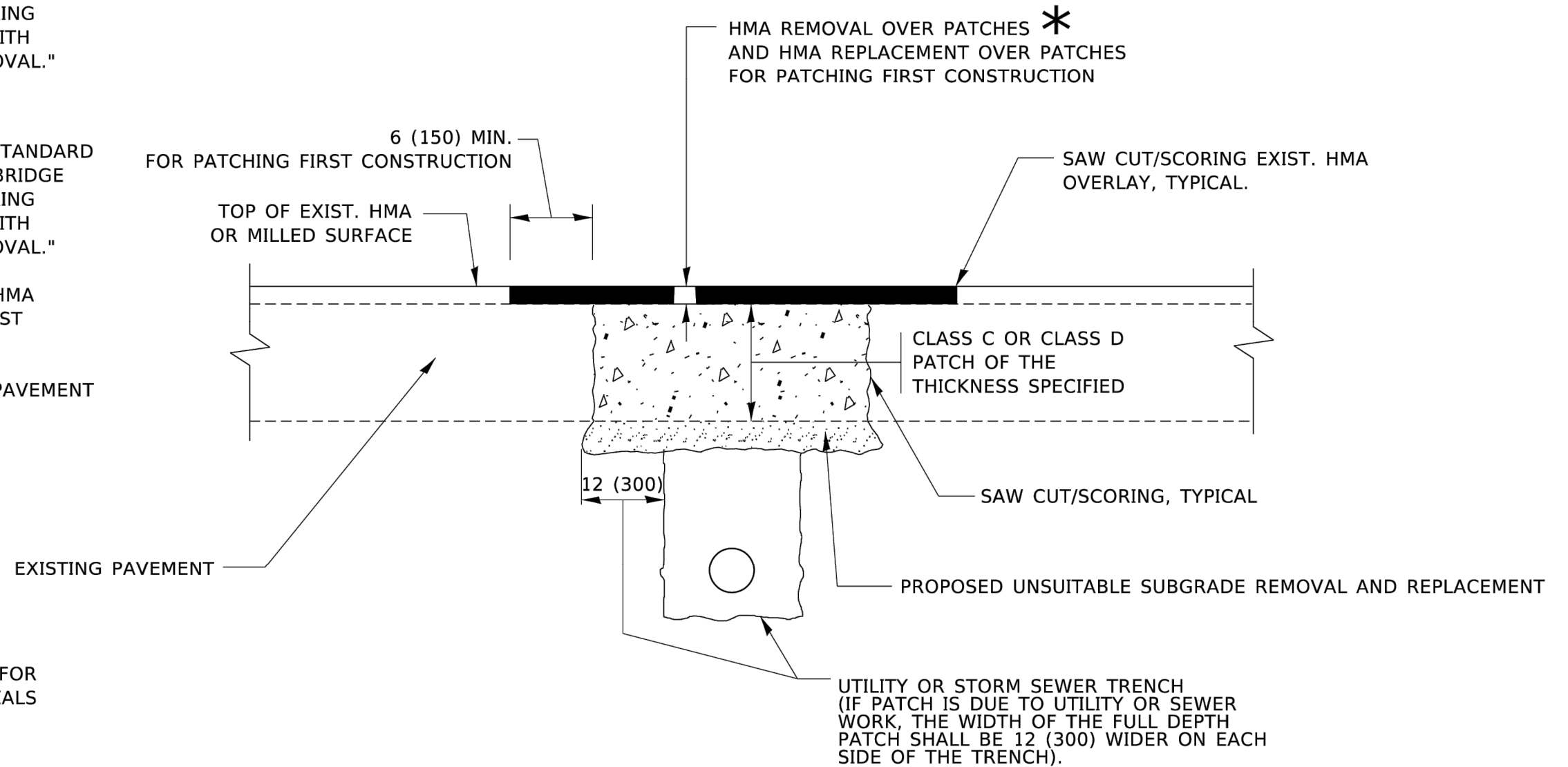

SEQUENCE OF CONSTRUCTION (PATCHING FIRST)

1. REMOVE THE EXISTING HMA MATERIAL OVER THE AREA TO BE PATCHED.
2. REMOVE AND REPLACE WITH CLASS C OR D PATCH.
3. REPLACE HMA MATERIAL OVER THE AREA TO BE PATCHED.

SEQUENCE OF CONSTRUCTION (MILLING FIRST)

1. MILL HMA FIRST IF THERE IS AT LEAST 4½ INCHES OR MORE OF HMA MATERIAL ON TOP OF THE EXISTING PAVEMENT OR IF THE PAVEMENT IS FULL DEPTH HMA. A MINIMUM OF 2 INCHES OF HMA MATERIAL SHALL BE IN PLACE AFTER MILLING.
2. REMOVE AND REPLACE WITH FULL DEPTH CLASS D PATCHES TO TOP OF MILLED SURFACE.

ALL DIMENSIONS ARE IN INCHES (MILLIMETERS) UNLESS OTHERWISE SHOWN.

MODEL: User:it
 FILE: N:\mhc\pww\l\dot-pww-bentley.com\PROJECTS\DOT Documents\DOT Offices\District 1\Projects\Dist1\2223\CA\DistalCA\shhets\222.dgn

USER NAME = Lawrence.DeManche	DESIGNED - R. SHAH	REVISED - R. BORO 01-01-07
	DRAWN -	REVISED - R. BORO 09-04-07
PLOT SCALE = 100.0000' / in.	CHECKED -	REVISED - K. ENG 10-27-08
PLOT DATE = 11/18/2022	DATE - 10-25-94	REVISED - K. SMITH 11-18-22

**STATE OF ILLINOIS
DEPARTMENT OF TRANSPORTATION**

**PAVEMENT PATCHING FOR
HMA SURFACED PAVEMENT**

SCALE: NONE SHEET 1 OF 1 SHEETS STA. TO STA.

F.A. RTE.	SECTION	COUNTY	TOTAL SHEETS	SHEET NO.
2513 1031	23-00363-00-RS	KANE	21	15
BD400-04 (BD-22)			CONTRACT NO. 61K23	
ILLINOIS FED. AID PROJECT				

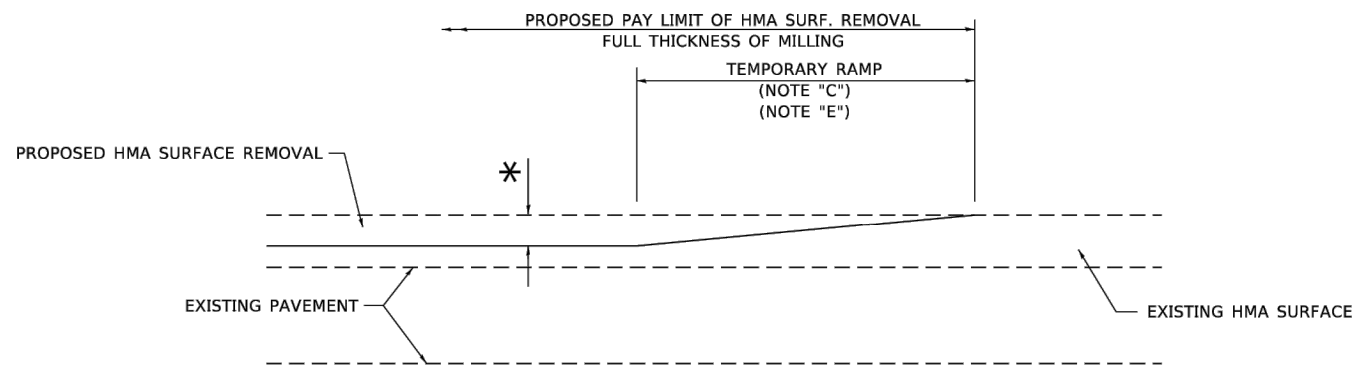

MILLED TEMPORARY RAMP

(FOR BUTT JOINT AND HMA TAPER SEE DETAIL BELOW)

OPTION 1

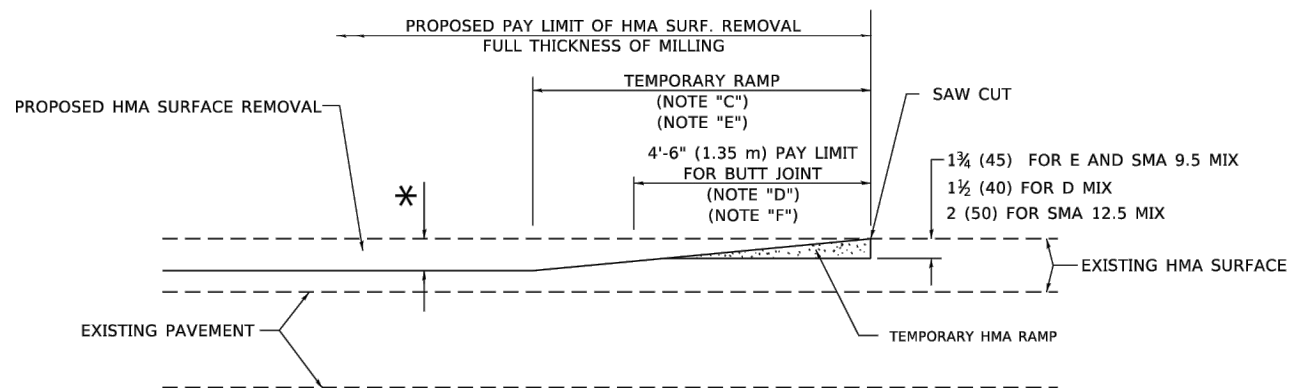

HMA CONSTRUCTED TEMPORARY RAMP

(FOR BUTT JOINT AND HMA TAPER SEE DETAIL BELOW)

OPTION 2

TYPICAL TEMPORARY RAMP

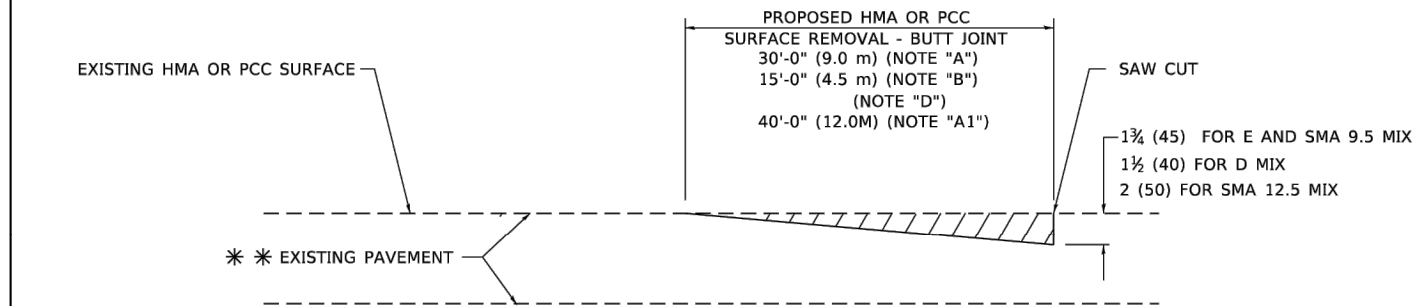

BUTT JOINT DETAIL

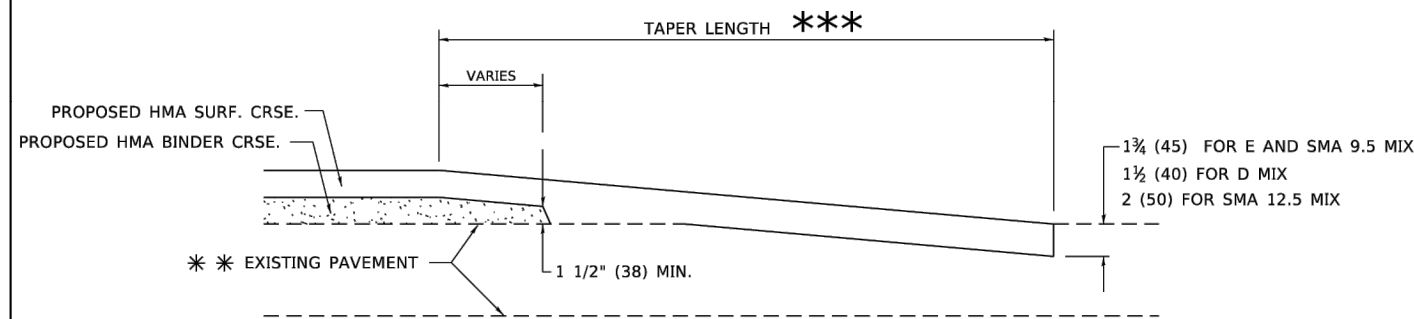

HMA TAPER DETAIL

TYPICAL BUTT JOINT AND HMA TAPER FOR RESURFACING ONLY

*** PC CONCRETE, HMA OR HMA RESURFACED PAVEMENT.

GENERAL NOTES

- A. MAINLINE ARTERIAL ROADWAYS AND MAJOR SIDE ROADS.
- A1. INTERSTATES
- B. MINOR SIDE ROADS.
- C. THE TEMP. RAMP SHALL BE CONSTRUCTED IMMEDIATELY UPON REMOVAL OF THE EXISTING HMA SURFACE.
- D. THE BUTT JOINT SHALL BE CONSTRUCTED IMMEDIATELY PRIOR TO PLACING THE PROPOSED HMA COURSES.
- E. TAPER THE TEMP. RAMP AT A RATE OF 3' - 4" (1.02m) PER 1 INCH (25 mm) OF MILLING THICKNESS.
 - * SEE TYPICAL SECTIONS FOR MILLING THICKNESS.
- F. SEE ARTICLE 406.08 AND 406.14 OF THE STANDARD SPECIFICATIONS FOR "HMA AND/OR PCC SURFACE REMOVAL, BUTT JOINT".
 - *** 20'-0" (6.1 m) PER 1 (25) RESURFACING (NOTE "A")
 - 10'-0" (3.0 m) PER 1 (25) RESURFACING (NOTE "B")

BASIS OF PAYMENT

- 1. THE BUTT JOINT WILL BE PAID FOR AT THE CONTRACT UNIT PRICE PER SQUARE YARD (SQUARE METER) FOR "HOT-MIX ASPHALT SURFACE REMOVAL - BUTT JOINT" OR FOR "PORTLAND CEMENT CONCRETE SURFACE REMOVAL- BUTT JOINT".
- 2. THE TEMPORARY RAMP AND SAW CUT SHALL BE INCLUDED IN THE UNIT COST FOR HMA OR PCC SURFACE REMOVAL-BUTT JOINT.

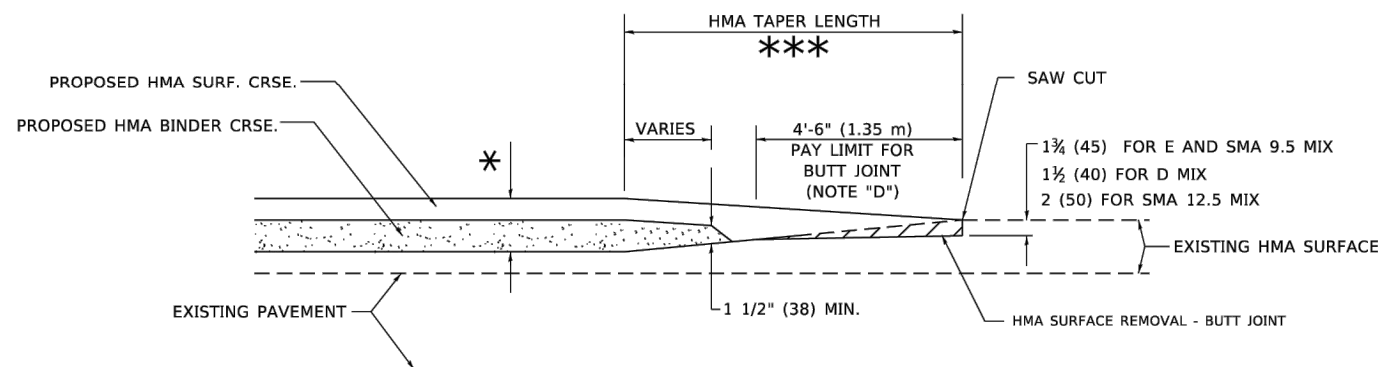

BUTT JOINT AND HMA TAPER

TYPICAL BUTT JOINT AND HMA TAPER FOR MILLING AND RESURFACING

ALL DIMENSIONS ARE IN INCHES (MILLIMETERS) UNLESS OTHERWISE SHOWN.

MODEL: Default; FILE NAME: p:\w\l\del-pw-bentley.com-p\WIDOT\Documents\DOT Office\District 1\Projects\Dist1\52723\3A\CAD\Drawn\CAD\sheet\1643.dgn

USER NAME = Lawrence.DeManche	DESIGNED - M. DE YONG	REVISED - A. ABBAS 03-21-97
	DRAWN -	REVISED - M. GOMEZ 04-06-01
PLOT SCALE = 100.0000' / in.	CHECKED -	REVISED - R. BORO 01-01-07
PLOT DATE = 11/18/2022	DATE - 06-13-90	REVISED - K. SMITH 11-18-22

STATE OF ILLINOIS
DEPARTMENT OF TRANSPORTATION

SCALE: NONE		SHEET 1 OF 1 SHEETS		STA.	TO STA.
-------------	--	---------------------	--	------	---------

BUTT JOINT AND
HMA TAPER DETAILS

F.A. RTE.	SECTION	COUNTY	TOTAL SHEETS	SHEET NO.
2513 1031	23-00363-00-RS	KANE	21	17
BD400-05 BD-32		CONTRACT NO. 61K23		
ILLINOIS FED. AID PROJECT				

MODEL: Default
 FILE NAME: p:\w\1084848\BENTEG.illinois.gov.PWIDOT\Documents\DOT_Offices\District_1\Projects\DI\552234\CAD\Drawn\CADsheets\TC10.dgn

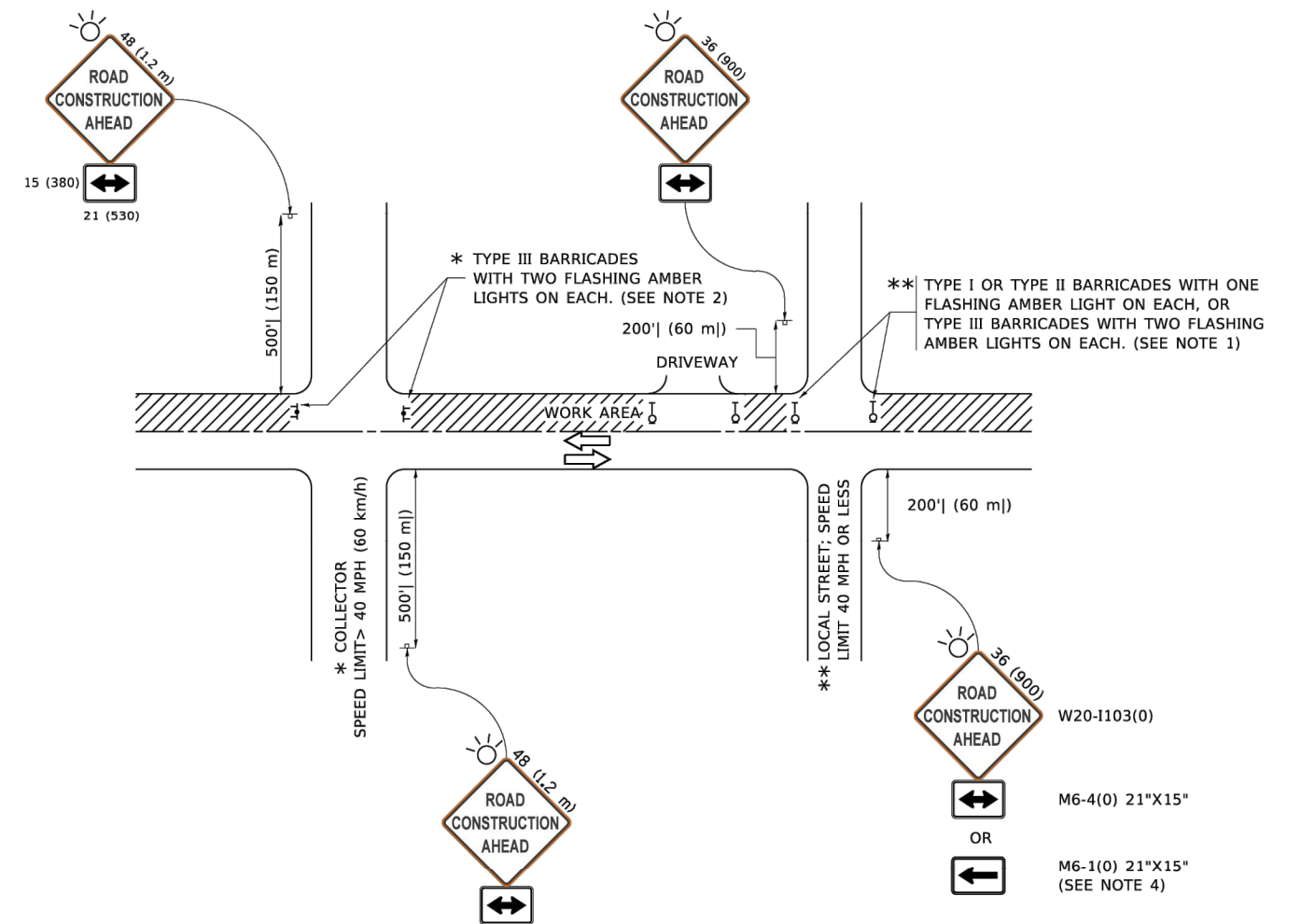

NOTES:

1. SIDE ROAD WITH A SPEED LIMIT OF 40 MPH (60 km/h) OR LESS AS SHOWN ON THE DRAWING AND AS DIRECTED BY THE ENGINEER:
 - a) ONE "ROAD CONSTRUCTION AHEAD" SIGN 36 x 36 (900x900) WITH A FLASHER MOUNTED ON IT APPROXIMATELY 200' (60 m) IN ADVANCE OF THE MAIN ROUTE.
 - b) THE CLOSED PORTION OF THE MAIN ROUTE SHALL BE PROTECTED BY BLOCKING WITH TYPE I, TYPE II OR TYPE III BARRICADES, 1/3 OF THE CROSS SECTION OF THE CLOSED PORTION.
2. SIDE ROAD WITH A SPEED LIMIT GREATER THAN 40 MPH (60 km/h) AS SHOWN ON THE DRAWING AND AS DIRECTED BY THE ENGINEER:
 - a) ONE "ROAD CONSTRUCTION AHEAD" SIGN 48 x 48 (1.2 m x 1.2 m) WITH A FLASHER MOUNTED ON IT APPROXIMATELY 500' (150 m) IN ADVANCE OF THE MAIN ROUTE.
 - b) BLOCKING WITH TYPE III BARRICADES, 1/2 OF THE CROSS SECTION OF THE CLOSED PORTION.
3. CONES MAY BE SUBSTITUTED FOR BARRICADES OR DRUMS AT HALF THE SPACING DURING DAY OPERATIONS. CONES SHALL BE A MINIMUM OF 28 (710) IN HEIGHT.
4. SIGNING AND THE WORK ZONE, A SINGLE HEADED ARROW (M6-1) SHALL BE USED IN LIEU OF THE DOUBLE HEADED ARROW (M6-4).
5. WHEN WORK IS BEING PERFORMED ON A SIDE ROAD OR DRIVEWAY, FOLLOW THE APPLICABLE STANDARD(S). THE DIRECTIONAL ARROW (M6-1 OR M6-4) SHALL BE COVERED OR REMOVED WHEN NO LONGER CONSISTENT WITH THE TRAFFIC CONTROL SET-UP.
6. ADVANCE WARNING SIGNS ARE TO BE OMITTED ON DRIVEWAYS UNLESS OTHERWISE SPECIFIED IN THE PLANS OR BY THE ENGINEER.
7. THE TRAFFIC CONTROL AND PROTECTION FOR SIDE ROADS, INTERSECTIONS, AND DRIVEWAYS SHALL BE INCLUDED IN THE COST OF SPECIFIED TRAFFIC CONTROL STANDARDS OR ITEMS.

All dimensions are in inches (millimeters) unless otherwise shown.

USER NAME = footemj	DESIGNED - L.H.A.	REVISED - A. HOUSEH 10-15-96
	DRAWN -	REVISED - T. RAMMACHER 01-06-00
PLOT SCALE = 50.0000" / in.	CHECKED -	REVISED - A. SCHUETZE 07-01-13
PLOT DATE = 3/4/2019	DATE - 06-89	REVISED - A. SCHUETZE 09-15-16

**STATE OF ILLINOIS
 DEPARTMENT OF TRANSPORTATION**

**TRAFFIC CONTROL AND PROTECTION FOR
 SIDE ROADS, INTERSECTIONS, AND DRIVEWAYS**

SCALE: NONE SHEET 1 OF 1 SHEETS STA. TO STA.

F.A. RTE.	SECTION	COUNTY	TOTAL SHEETS	SHEET NO.
2513 1031	23-00363-00-RS	KANE	21	18
TC-10			CONTRACT NO. 61K23	
ILLINOIS FED. AID PROJECT				

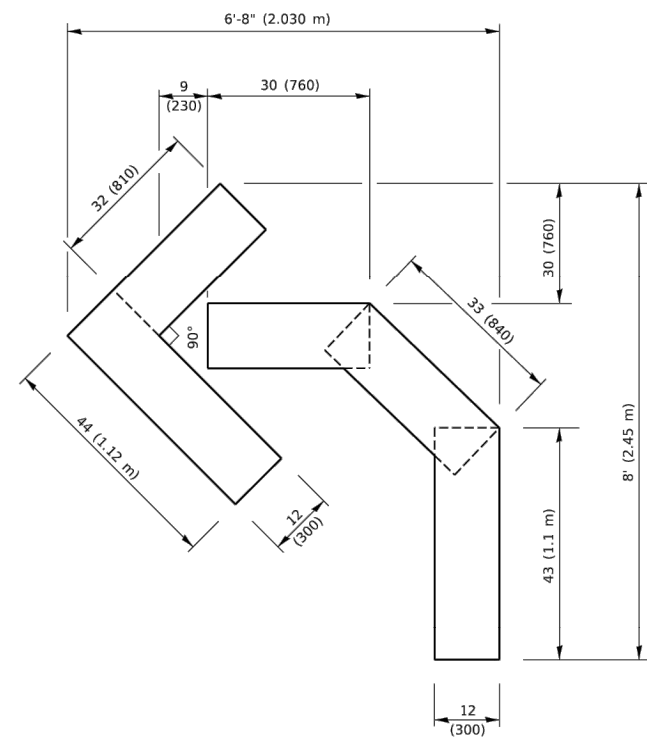

QUANTITY

4 (100) LINE = 45.5 ft. (13.9 m)
15.2 sq. ft. (1.41 sq. m)

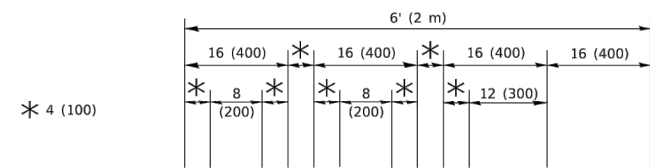

QUANTITY

4 (100) LINE = 64.1 ft. (19.5 m)
21.4 sq. ft. (1.99 sq. m)

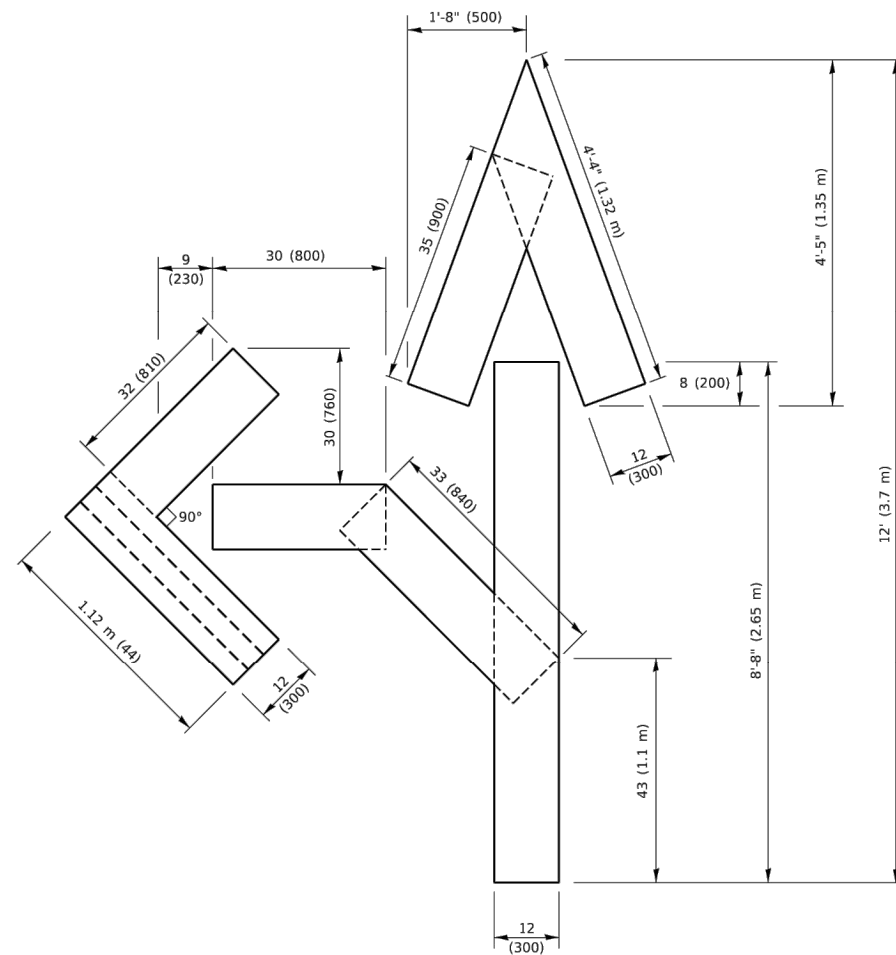

QUANTITY

4 (100) LINE = 82.5 ft. (25.1 m)
27.5 sq. ft. (2.53 sq. m)

NOTE:

ALL QUANTITIES OF PLACEMENT ARE REPRESENTED IN LINEAR FEET OF 4" LINES TO MATCH THE 4" TEMPORARY TAPE PAY ITEM AND REPRESENTS THE TOTAL QUANTITY OF 4" TAPE REQUIRED.

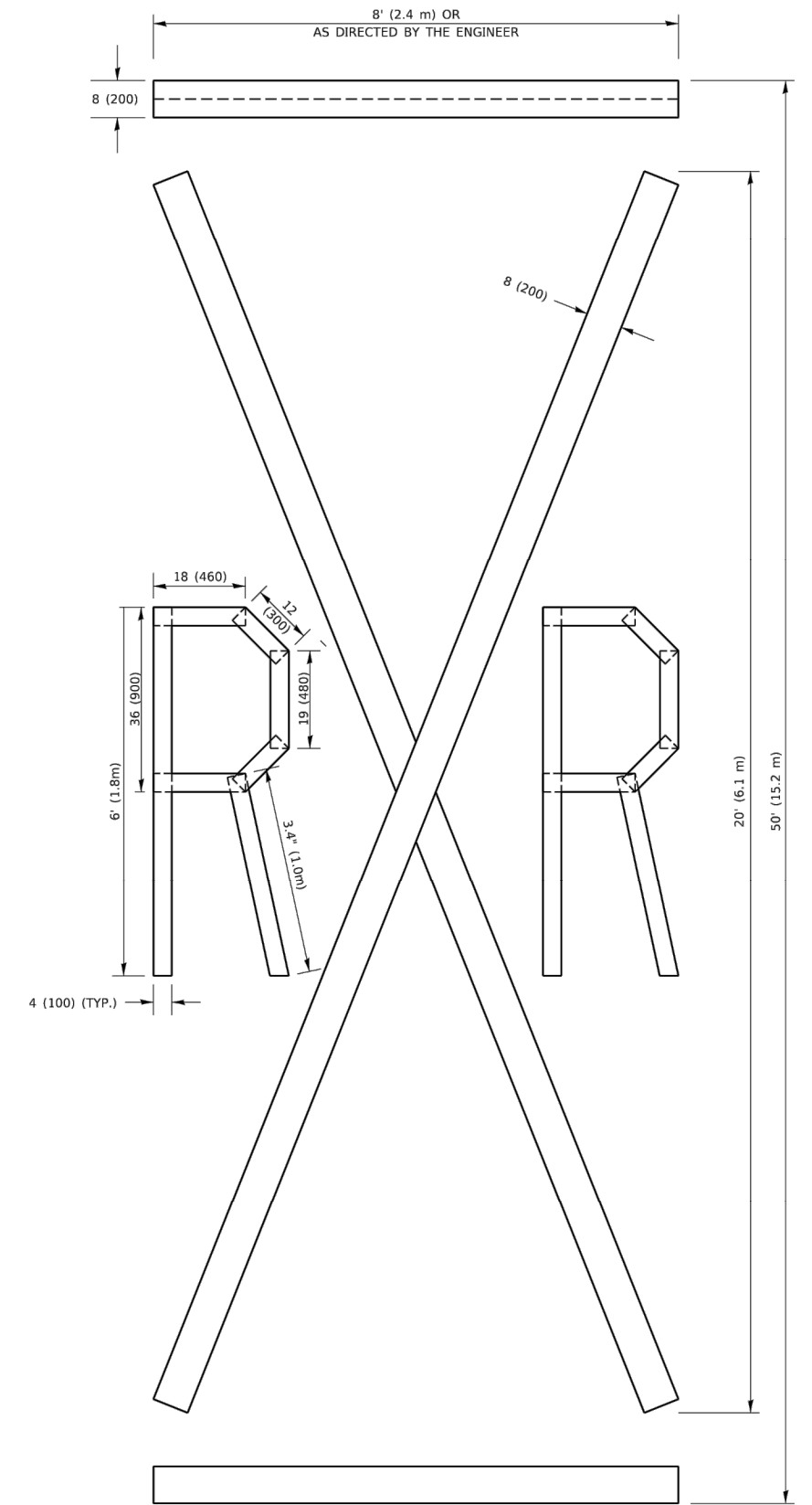

QUANTITY

4 (100) LINE = 225.9 ft. (68.9 m)
75.3 sq. ft. (6.99 sq. m)

All dimensions are in inches (millimeters) unless otherwise shown.

MODEL: Default
FILE NAME: p:\1108\FEB\NITEG.illinois.gov-PWIDOT\Documents\DOT_Offices\District_1\Projects\Dist1\St22\24\CAD\Drawn\CAD\sheet1.ctb.dgn

USER NAME = footemj	DESIGNED -	REVISED - T. RAMMACHER 03-02-98
	DRAWN -	REVISED - E. GOMEZ 08-28-00
PLOT SCALE = 50.0068" / in.	CHECKED -	REVISED - E. GOMEZ 08-28-00
PLOT DATE = 3/4/2019	DATE - 09-18-94	REVISED - A. SCHUETZE 09-15-16

**STATE OF ILLINOIS
DEPARTMENT OF TRANSPORTATION**

SHORT TERM PAVEMENT MARKING LETTERS AND SYMBOLS

SCALE: NONE SHEET 1 OF 1 SHEETS STA. TO STA.

F.A. RTE.	SECTION	COUNTY	TOTAL SHEETS	SHEET NO.
2513 1031	23-00363-00-RS	KANE	21	20
TC-16			CONTRACT NO. 61K23	
ILLINOIS FED. AID PROJECT				

MODEL: Default
 FILE NAME: p:\u01684848\BID\NTEG_IL\Illinois.gov.PWIDOT\Documents\DOT_Offices\District_1\Projects\US52\234\CAD\Drawn\CADsheets\22.dgn

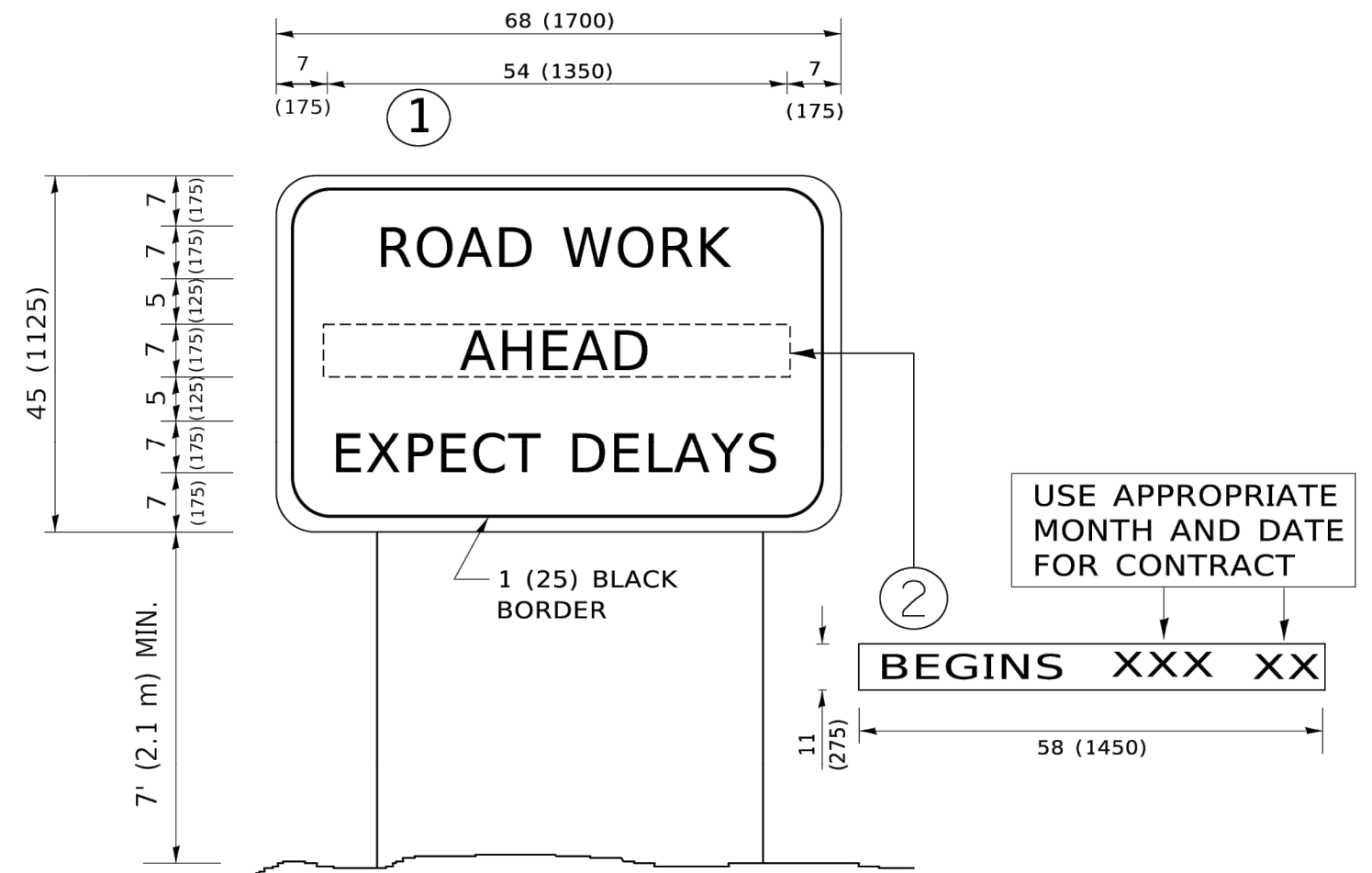

NOTES:

1. USE BLACK LETTERING ON ORANGE BACKGROUND.
2. ERECT SIGNS IN ADVANCE OF THE LOCATION FOR THE "ROAD CONSTRUCTION AHEAD" SIGN AT LOCATIONS AS DIRECTED BY THE ENGINEER.
3. ERECT SIGN ① WITH INSTALLED PANEL ② ONE WEEK PRIOR TO THE START OF CONSTRUCTION.
4. REMOVE PANEL ② SOON AFTER THE START OF CONSTRUCTION.
5. SEE SPECIAL PROVISION FOR "TEMPORARY INFORMATION SIGNING" FOR ADDITIONAL INFORMATION.
6. ONE SIGN ASSEMBLY EQUALS 25.70 SQ. FT. (2.3 SQ. M.)
7. SHALL BE PAID FOR AS TEMPORARY INFORMATION SIGNING.

ALL DIMENSIONS ARE IN INCHES (MILLIMETERS)
 UNLESS OTHERWISE SHOWN.

USER NAME = footemj	DESIGNED -	REVISED - R. MIRS 09-15-97
	DRAWN -	REVISED - R. MIRS 12-11-97
PLOT SCALE = 50.0000" / in.	CHECKED -	REVISED - T. RAMMACHER 02-02-99
PLOT DATE = 3/4/2019	DATE -	REVISED - C. JUCIUS 01-31-07

**STATE OF ILLINOIS
 DEPARTMENT OF TRANSPORTATION**

**ARTERIAL ROAD
 INFORMATION SIGN**

SCALE: NONE SHEET 1 OF 1 SHEETS STA. TO STA.

F.A. RTE.	SECTION	COUNTY	TOTAL SHEETS	SHEET NO.
2513 1031	23-00363-00-RS	KANE	21	21
TC-22			CONTRACT NO. 61K23	
ILLINOIS FED. AID PROJECT				