

ENTRANCE SCHEDULE

STATION	OFFSET	ENTRANCE TYPE	ENTRANCE WIDTH "W" (FOOT)	ENTRANCE DEPTH "Y" (FOOT)	DRIVE PAVEMENT REM (SQ YD)	PCC DRIVEWAY PAVT 6 (SQ YD)	PCC DRIVEWAY PAVT 8 (SQ YD)
100+88	LT	C.E.	24.0	0.0	26		26
101+52	LT	C.E.	24.0	0.0	23		23
101+92	LT	C.E.	31.0	0.0	26		27
104+44	LT	C.E.	12.0	7.0	16		20
104+78	LT	C.E.	16.0	5.0	43		24
105+75	LT	C.E.	24.0	0.0	23		20
106+61	LT	C.E.	35.0	0.0	32		28
108+35	LT	C.E.	24.0	0.0	20		20
109+14	LT	C.E.	24.0	0.0	13		20
111+25	LT	P.E.	12.0	0.0	8	12	
111+69	LT	C.E.	24.0	0.0	19		20
112+03	LT	C.E.	24.0	0.0	27		20
115+88	LT	C.E.	32.0	4.0	36		40
116+41	LT	C.E.	32.0	0.0	24		26
118+41	LT	C.E.	26.0	5.0	32		33
TOTAL					368	12	347

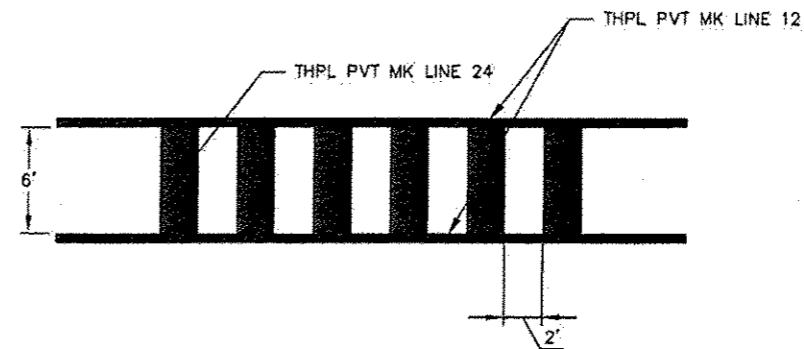

208 East Main Street, Suite 100
Belleville, Illinois 62220
618.233.5877 phone
618.233.5977 fax
www.kaskaskiaeng.com

Kaskaskia
Engineering Group, LLC

PROFESSIONAL REGISTRATIONS
Illinois Professional Design Firm
Professional Engineering Group

LICENSE NO. 184-004773
20-5080586

PREPARED BY:

SHEET TITLE:
ROADWAY DETAILS & ENTRANCE SCHEDULE

PROJECT TITLE:
SEC 10-00085-01-LS
NORTH MAIN STREET STREETSCAPE
CITY OF EDWARDSVILLE, ILLINOIS

DESIGNED BY: SAIS	SHEET
DRAWN BY: SAIS	18
CHECKED BY: LDC	
DATE OF PRE-FINAL: 8/17/12	
DATE OF FINAL: 10/12/12	
SHEET NO. 18 OF 18 SHEETS	
PROJECT NUMBER 09-1073.01	

FILE: P:\09-1074 Edwardsville N Main St Streetscape\10_CAD\CADD Sheets\09-1074-TEP Details.dwg