

02A

Letting March 6, 2020

Notice to Bidders, Specifications and Proposal



**Illinois Department
of Transportation**

Springfield, Illinois 62764

**Contract No. AU070
Aurora Municipal Airport
Aurora, Illinois
Kane County
Illinois Project No. ARR-4352
SBG Project No. 3-17-SBGP-156**



1. **TIME AND PLACE OF OPENING BIDS.** Electronic bids are to be submitted to the electronic bidding system (iCX-Integrated Contractors Exchange). All bids must be submitted to the iCX system prior to 10:00 a.m. on March 6, 2020, at which time the bids will be publicly opened from the iCX SecureVault.
2. **DESCRIPTION OF WORK.** The proposed improvement is identified and advertised for bids in the Invitation for Bids as:

**Contract No. AU070
Aurora Municipal Airport
Aurora, Illinois
Kane County
Illinois Project No. ARR-4352
SBG Project No. 3-17-SBGP-156**

Airfield Pavement Rehabilitation, Phase 3 (Area 1)

For engineering information, please contact Antonio R. Marin, P.E. of Crawford, Murphy & Tilly, Inc. at 630.907.7041.

3. INSTRUCTIONS TO BIDDERS.

- (a) This Notice, the invitation for bids, proposal and letter of award shall, together with all other documents in accordance with Article 10-18 of the Illinois Standard Specifications for Construction of Airports, become part of the contract. Bidders are cautioned to read and examine carefully all documents, to make all required inspections, and to inquire or seek explanation of the same prior to submission of a bid.
- (b) State law, and, if the work is to be paid wholly or in part with Federal-aid funds, Federal law requires the bidder to make various certifications as a part of the proposal and contract. By execution and submission of the proposal, the bidder makes the certification contained therein. A false or fraudulent certification shall, in addition to all other remedies provided by law, be a breach of contract and may result in termination of the contract.

4. **AWARD CRITERIA AND REJECTION OF BIDS.** This contract will be awarded within 90 calendar days to the lowest responsive and responsible bidder considering conformity with the terms and conditions established by the Department in the rules, Invitation for Bids and contract documents. The issuance of plans and proposal forms for bidding based upon a prequalification rating shall not be the sole determinant of responsibility. The Department reserves the right to determine responsibility at the time of award, to reject any or all proposals, to readvertise the proposed improvement, and to waive technicalities.

5. **PRE-BID CONFERENCE.** N/A

6. **DISADVANTAGED BUSINESS POLICY.** The DBE goal for this contract is 8.0%.

7. **SPECIFICATIONS AND DRAWINGS.** The work shall be done in accordance with the Illinois Standard Specifications for Construction of Airports, the Special Provisions dated January 10, 2020, and the Construction Plans dated January 10, 2020 as approved by the Illinois Department of Transportation, Division of Aeronautics.

- 8. BIDDING REQUIREMENTS AND BASIS OF AWARD.** When alternates are included in the proposal, the following shall apply:
- a. Additive Alternates
 - (1) Bidders must submit a bid for the Base Bid and for all Additive Alternates.
 - (2) Award of this contract will be made to the lowest responsible qualified bidder computed as follows:

The lowest aggregate amount of (i) the Base Bid plus (ii) any Additive Alternate(s) which the Department elects to award.

The Department may elect not to award any Additive Alternates. In that case, award will be to the lowest responsible qualified bidder of the Base Bid.
 - b. Optional Alternates
 - (1) Bidders must submit a bid for the Base Bid and for either Alternate A or Alternate B or for both Alternate A and Alternate B.
 - (2) Award of this contract will be made to the lowest responsible qualified bidder computed as follows:

The lower of the aggregate of either (i) the Base Bid plus Alternate A or (ii) the Base Bid plus Alternate B.
- 9. CONTRACT TIME.** The Contractor shall complete all work within the specified contract time. Any calendar day extension beyond the specified contract time must be fully justified, requested by the Contractor in writing, and approved by the Engineer, or be subject to liquidated damages.
- The contract time for this contract is Base Bid: 34 calendar days; Additive Alternate #1: 1 additional calendar day; Additive Alternate #2: 2 additional calendar days.
- 10. INDEPENDENT WEIGHT CHECKS.** The Department reserves the right to conduct random unannounced independent weight checks on any delivery for bituminous, aggregate or other pay item for which the method of measurement for payment is based on weight. The weight checks will be accomplished by selecting, at random, a loaded truck and obtaining a loaded and empty weight on an independent scale. In addition, the department may perform random weight checks by obtaining loaded and empty truck weights on portable scales operated by department personnel.
- 11. MATERIAL COST ADJUSTMENTS.** Federal Aviation Administration rules prohibit the use of escalation clauses for materials. Therefore, the Illinois Department of Transportation, Division of Aeronautics cannot offer any material cost adjustment provisions for projects that utilize Federal Funds.
- 12. GOOD FAITH COMPLIANCE.** The Illinois Department of Transportation has made a good faith effort to include all statements, requirements, and other language required by federal and state law and by various offices within federal and state governments whether that language is required by law or not. If anything of this nature has been left out or if additional language etc. is later required, the bidder/contractor shall cooperate fully with the Department to modify the contract or bid documents to correct the deficiency. If the change results in increased operational costs, the Department shall reimburse the contractor for such costs as it may find to be reasonable.

By Order of the
Illinois Department of Transportation

Omer Osman,
Acting Secretary

ILLINOIS DEPARTMENT OF TRANSPORTATION
DIVISION OF AERONAUTICS

REQUIRED CONTRACT PROVISIONS FOR STATE FUNDED AIRPORT CONSTRUCTION PROJECTS

The following provisions are State of Illinois requirements and are in addition to the REQUIRED CONTRACT PROVISIONS FOR AIRPORT IMPROVEMENT PROGRAM AND FOR OBLIGATED SPONSORS

DISADVANTAGED BUSINESS POLICY

NOTICE: This proposal contains the special provision entitled "Disadvantaged Business Participation." Inclusion of this Special Provision in this contract satisfies the obligations of the Department of Transportation under federal law as implemented by 49 CFR 23 and under the Illinois "Minority and Female Business Enterprise Act."

POLICY: It is public policy that the businesses defined in 49 CFR Part 23 shall have the maximum opportunity to participate in the performance of contracts financed in whole or in part with State or Federal funds. Consequently, the requirements of 49 CFR Part 23 apply to this contract.

OBLIGATION: The Contractor agrees to ensure that the businesses defined in 49 CFR Part 23 have the maximum opportunity to participate in the performance of this contract. In this regard, the Contractor shall take all necessary and reasonable steps, in accordance with 49 CFR Part 23, to ensure that the said businesses have the maximum opportunity to compete for and perform portions of this contract. The Contractor shall not discriminate on the basis of race, color, national origin, or sex in the selection and retention of subcontractors, including procurement of materials and leases of equipment.

The Contractor shall include the above Policy and Obligation statements of this Special Provision in every subcontract, including procurement of materials and leases of equipment.

DBE/WBE CONTRACTOR FINANCE PROGRAM: On contracts where a loan has been obtained through the DBE/WBE Contractor Finance Program, the Contractor shall cooperate with the Department by making all payments due to the DBE/WBE Contractor by means of a two-payee check payable to the Lender (Bank) and the Borrower (DBE/WBE Contractor).

BREACH OF CONTRACT: Failure to carry out the requirements set forth above and in the Special Provision shall constitute a breach of contract and may result in termination of the contract or liquidated damages as provided in the special provision.

SPECIAL PROVISION FOR DISADVANTAGED BUSINESS ENTERPRISE PARTICIPATION (BDE)

Effective: September 1, 2000

Revised: March 2, 2019

FEDERAL OBLIGATION. The Department of Transportation, as a recipient of federal financial assistance, is required to take all necessary and reasonable steps to ensure nondiscrimination in the award and administration of contracts. Consequently, the federal regulatory provisions of 49 CFR Part 26 apply to this contract concerning the utilization of disadvantaged business enterprises. For the purposes of this Special Provision, a disadvantaged business enterprise (DBE) means a business certified by the Department in accordance with the requirements of 49 CFR Part 26 and listed in the Illinois Unified Certification Program (IL UCP) DBE Directory.

STATE OBLIGATION. This Special Provision will also be used by the Department to satisfy the requirements of the Business Enterprise for Minorities, Females, and Persons with Disabilities Act, 30 ILCS 575. When this Special Provision is used to satisfy state law requirements on 100 percent state-funded contracts, the federal government has no involvement in such contracts (not a federal-aid contract) and no responsibility to oversee the implementation of this Special Provision by the Department on those contracts. DBE participation on 100 percent state-funded contracts will not be credited toward fulfilling the Department's annual overall DBE goal required by the US Department of Transportation to comply with the federal DBE program requirements.

CONTRACTOR ASSURANCE. The Contractor makes the following assurance and agrees to include the assurance in each subcontract the Contractor signs with a subcontractor.

The Contractor, subrecipient, or subcontractor shall not discriminate on the basis of race, color, national origin, or sex in the performance of this contract. The Contractor shall carry out applicable requirements of 49 CFR Part 26 in the award and administration of contracts funded in whole or in part with federal or state funds. Failure by the Contractor to carry out these requirements is a material breach of this contract, which may result in the termination of this contract or such other remedy as the recipient deems appropriate, which may include, but is not limited to:

- (a) Withholding progress payments;
- (b) Assessing sanctions;
- (c) Liquidated damages; and/or
- (d) Disqualifying the Contractor from future bidding as non-responsible.

OVERALL GOAL SET FOR THE DEPARTMENT. As a requirement of compliance with 49 CFR Part 26, the Department has set an overall goal for DBE participation in its federally assisted contracts. That goal applies to all federal-aid funds the Department will expend in its federally assisted contracts for the subject reporting fiscal year. The Department is required to make a good faith effort to achieve the overall goal. The dollar amount paid to all approved DBE companies performing work called for in this contract is eligible to be credited toward fulfillment of the Department's overall goal.

CONTRACT GOAL TO BE ACHIEVED BY THE CONTRACTOR. This contract includes a specific DBE utilization goal established by the Department. The goal has been included because the Department has determined the work of this contract has subcontracting opportunities that may be suitable for performance by DBE companies. The determination is based on an assessment of the type of work, the location of the work, and the availability of DBE companies to do a part of the work. The assessment indicates, in the absence of unlawful discrimination and in an arena of fair and open competition, DBE companies can be expected to perform 8.0% of the work. This percentage is set as the DBE participation goal for this contract. Consequently, in addition to the other award criteria established for this contract, the Department will only award this contract to a bidder who makes a good faith effort to meet this goal of DBE participation in the performance of the work. A bidder makes a good faith effort for award consideration if either of the following is done in accordance with the procedures set for in this Special Provision:

- (a) The bidder documents enough DBE participation has been obtained to meet the goal or,
- (b) The bidder documents a good faith effort has been made to meet the goal, even though the effort did not succeed in obtaining enough DBE participation to meet the goal.

DBE LOCATOR REFERENCES. Bidders shall consult the IL UCP DBE Directory as a reference source for DBE-certified companies. In addition, the Department maintains a letting and item specific DBE locator information system whereby DBE companies can register their interest in providing quotes on particular bid items advertised for letting. Information concerning DBE companies willing to quote work for particular contracts may be obtained by contacting the Department's Bureau of Small Business Enterprises at telephone number (217) 785-4611, or by visiting the Department's website at:
<http://www.idot.illinois.gov/doing-business/certifications/disadvantaged-business-enterprise-certification/il-ucp-directory/index>.

BIDDING PROCEDURES. Compliance with this Special Provision is a material bidding requirement and failure of the bidder to comply will render the bid not responsive.

The bidder shall submit a DBE Utilization Plan (form SBE 2026), and a DBE Participation Statement (form SBE 2025) for each DBE company proposed for the performance of work to achieve the contract goal, with the bid. If the Utilization Plan indicates the contract goal will not be met, documentation of good faith efforts shall also be submitted. The documentation of good faith efforts must include copies of each DBE and non-DBE subcontractor quote submitted to the bidder when a non-DBE subcontractor is selected over a DBE for work on the contract. The required forms and documentation must be submitted as a single .pdf file using the "Integrated Contractor Exchange (iCX)" application within the Department's "EBids System".

The Department will not accept a Utilization Plan if it does not meet the bidding procedures set forth herein and the bid will be declared not responsive. In the event the bid is declared not responsive, the Department may elect to cause the forfeiture of the penal sum of the bidder's proposal guaranty and may deny authorization to bid the project if re-advertised for bids.

GOOD FAITH EFFORT PROCEDURES. The contract will not be awarded until the Utilization Plan is approved. All information submitted by the bidder must be complete, accurate and adequately document enough DBE participation has been obtained or document the good faith efforts of the bidder, in the event enough DBE participation has not been obtained, before the Department will commit to the performance of the contract by the bidder. The Utilization Plan will be approved by the Department if the Utilization Plan documents sufficient commercially useful DBE work to meet the contract goal or the bidder submits sufficient documentation of a good faith effort to meet the contract goal pursuant to 49 CFR Part 26, Appendix A. This means the bidder must show that all necessary and reasonable steps were taken to achieve the contract goal. Necessary and reasonable steps are those which, by their scope, intensity and appropriateness to the objective, could reasonably be expected to obtain sufficient DBE participation, even if they were not successful. The Department will consider the quality, quantity, and intensity of the kinds of efforts the bidder has made. Mere *pro forma* efforts, in other words efforts done as a matter of form, are not good faith efforts; rather, the bidder is expected to have taken genuine efforts that would be reasonably expected of a bidder actively and aggressively trying to obtain DBE participation sufficient to meet the contract goal.

- (a) The following is a list of types of action that the Department will consider as part of the evaluation of the bidder's good faith efforts to obtain participation. These listed factors are not intended to be a mandatory checklist and are not intended to be exhaustive. Other factors or efforts brought to the attention of the Department may be relevant in appropriate cases and will be considered by the Department.

- (1) Soliciting through all reasonable and available means (e.g. attendance at pre-bid meetings, advertising and/or written notices) the interest of all certified DBE companies that have the capability to perform the work of the contract. The bidder must solicit this interest within sufficient time to allow the DBE companies to respond to the solicitation. The bidder must determine with certainty if the DBE companies are interested by taking appropriate steps to follow up initial solicitations.

(2) Selecting portions of the work to be performed by DBE companies in order to increase the likelihood that the DBE goals will be achieved. This includes, where appropriate, breaking out contract work items into economically feasible units to facilitate DBE participation, even when the Contractor might otherwise prefer to perform these work items with its own forces.

(3) Providing interested DBE companies with adequate information about the plans, specifications, and requirements of the contract in a timely manner to assist them in responding to a solicitation.

(4) a. Negotiating in good faith with interested DBE companies. It is the bidder's responsibility to make a portion of the work available to DBE subcontractors and suppliers and to select those portions of the work or material needs consistent with the available DBE subcontractors and suppliers, so as to facilitate DBE participation. Evidence of such negotiation includes the names, addresses, and telephone numbers of DBE companies that were considered; a description of the information provided regarding the plans and specifications for the work selected for subcontracting; and evidence as to why additional agreements could not be reached for DBE companies to perform the work.

b. A bidder using good business judgment would consider a number of factors in negotiating with subcontractors, including DBE subcontractors, and would take a firm's price and capabilities as well as contract goals into consideration. However, the fact that there may be some additional costs involved in finding and using DBE companies is not in itself sufficient reason for a bidder's failure to meet the contract DBE goal, as long as such costs are reasonable. Also the ability or desire of a bidder to perform the work of a contract with its own organization does not relieve the bidder of the responsibility to make good faith efforts. Bidders are not, however, required to accept higher quotes from DBE companies if the price difference is excessive or unreasonable. In accordance with the above Bidding Procedures, the documentation of good faith efforts must include copies of each DBE and non-DBE subcontractor quote submitted to the bidder when a non-DBE subcontractor was selected over a DBE for work on the contract.

(5) Not rejecting DBE companies as being unqualified without sound reasons based on a thorough investigation of their capabilities. The bidder's standing within its industry, membership in specific groups, organizations, or associations and political or social affiliations (for example union vs. non-union employee status) are not legitimate causes for the rejection or non-solicitation of bids in the bidder's efforts to meet the project goal.

(6) Making efforts to assist interested DBE companies in obtaining bonding, lines of credit, or insurance as required by the recipient or Contractor.

(7) Making efforts to assist interested DBE companies in obtaining necessary equipment, supplies, materials, or related assistance or services.

(8) Effectively using the services of available minority/women community organizations; minority/women contractors' groups; local, state, and federal minority/women business assistance offices; and other organizations as allowed on a case-by-case basis to provide assistance in the recruitment and placement of DBE companies.

(b) If the Department determines the bidder has made a good faith effort to secure the work commitment of DBE companies to meet the contract goal, the Department will award the contract provided it is otherwise eligible for award. If the Department determines the bidder has failed to meet the requirements of this Special Provision or that a good faith effort has not been made, the Department will notify the responsible company official designated in the Utilization Plan that the bid is not responsive. The notification will also include a statement of reasons for the adverse determination. If the Utilization Plan is not approved because it is deficient as a technical matter, unless waived by the Department, the bidder will be notified and will be allowed no more than a five calendar day period to cure the deficiency.

(c) The bidder may request administrative reconsideration of an adverse determination by emailing the Department at "DOT.DBE.UP@illinois.gov" within the five calendar days after the receipt of the notification of the determination. The determination shall become final if a request is not made on or before the fifth calendar day. A request may provide additional written documentation or argument concerning the issues raised in the determination statement of reasons, provided the documentation and arguments address efforts made prior to submitting the bid. The request will be reviewed by the Department's Reconsideration Officer. The Reconsideration Officer will extend an opportunity to the bidder to meet in person to consider all issues of documentation and whether the bidder made a good faith effort to meet the goal. After the review by the Reconsideration Officer, the bidder will be sent a written decision within ten working days after receipt of the request for reconsideration, explaining the basis for finding that the bidder did or did not meet the goal or make adequate good faith efforts to do so. A final decision by the Reconsideration Officer that a good faith effort was made shall approve the Utilization Plan submitted by the bidder and shall clear the contract for award. A final decision that a good faith effort was not made shall render the bid not responsive.

CALCULATING DBE PARTICIPATION. The Utilization Plan values represent work anticipated to be performed and paid for upon satisfactory completion. The Department is only able to count toward the achievement of the overall goal and the contract goal the value of payments made for the work actually performed by DBE companies. In addition, a DBE must perform a commercially useful function on the contract to be counted. A commercially useful function is generally performed when the DBE is responsible for the work and is carrying out its responsibilities by actually performing, managing, and supervising the work involved. The Department and Contractor are governed by the provisions of 49 CFR Part 26.55(c) on questions of commercially useful functions as it affects the work. Specific counting guidelines are provided in 49 CFR Part 26.55, the provisions of which govern over the summary contained herein.

(a) DBE as the Contractor: 100 percent goal credit for that portion of the work performed by the DBE's own forces, including the cost of materials and supplies. Work that a DBE subcontracts to a non-DBE does not count toward the DBE goals.

(b) DBE as a joint venture Contractor: 100 percent goal credit for that portion of the total dollar value of the contract equal to the distinct, clearly defined portion of the work performed by the DBE's own forces.

(c) DBE as a subcontractor: 100 percent goal credit for the work of the subcontract performed by the DBE's own forces, including the cost of materials and supplies, excluding the purchase of materials and supplies or the lease of equipment by the DBE subcontractor from the Contractor or its affiliates. Work that a DBE subcontractor in turn subcontracts to a non-DBE does not count toward the DBE goal.

(d) DBE as a trucker: 100 percent goal credit for trucking participation provided the DBE is responsible for the management and supervision of the entire trucking operation for which it is responsible. At least one truck owned, operated, licensed, and insured by the DBE must be used on the contract. Credit will be given for the following:

(1) The DBE may lease trucks from another DBE firm, including an owner-operator who is certified as a DBE. The DBE who leases trucks from another DBE receives credit for the total value of the transportation services the lessee DBE provides on the contract.

(2) The DBE may also lease trucks from a non-DBE firm, including from an owner-operator. The DBE who leases trucks from a non-DBE is entitled to credit only for the fee or commission it receives as a result of the lease arrangement.

(e) DBE as a material supplier:

(1) 60 percent goal credit for the cost of the materials or supplies purchased from a DBE regular dealer.

(2) 100 percent goal credit for the cost of materials or supplies obtained from a DBE manufacturer.

(3) 100 percent credit for the value of reasonable fees and commissions for the procurement of materials and supplies if not a DBE regular dealer or DBE manufacturer.

CONTRACT COMPLIANCE. Compliance with this Special Provision is an essential part of the contract. The Department is prohibited by federal regulations from crediting the participation of a DBE included in the Utilization Plan toward either the contract goal or the Department's overall goal until the amount to be applied toward the goals has been paid to the DBE. The following administrative procedures and remedies govern the compliance by the Contractor with the contractual obligations established by the Utilization Plan. After approval of the Utilization Plan and award of the contract, the Utilization Plan and individual DBE Participation Statements become part of the contract. If the Contractor did not succeed in obtaining enough DBE participation to achieve the advertised contract goal, and the Utilization Plan was approved and contract awarded based upon a determination of good faith, the total dollar value of DBE work calculated in the approved Utilization Plan as a percentage of the awarded contract value shall become the amended contract goal. All work indicated for performance by an approved DBE shall be performed, managed, and supervised by the DBE executing the DBE Participation Commitment Statement.

(a) NO AMENDMENT. No amendment to the Utilization Plan may be made without prior written approval from the Department's Bureau of Small Business Enterprises. All requests for amendment to the Utilization Plan shall be emailed to the Department at DOT.DBEP@illinois.gov.

(b) CHANGES TO WORK. Any deviation from the DBE condition-of-award or contract plans, specifications, or special provisions must be approved, in writing, by the Department as provided elsewhere in the Contract. The Contractor shall notify affected DBEs in writing of any changes in the scope of work which result in a reduction in the dollar amount condition-of-award to the contract. Where the revision includes work committed to a new DBE subcontractor, not previously involved in the project, then a Request for Approval of Subcontractor, Department form BC 260A or AER 260A, must be signed and submitted. If the commitment of work is in the form of additional tasks assigned to an existing subcontract, a new Request for Approval of Subcontractor will not be required. However, the Contractor must document efforts to assure the existing DBE subcontractor is capable of performing the additional work and has agreed in writing to the change.

(c) SUBCONTRACT. The Contractor must provide copies of DBE subcontracts to the Department upon request. Subcontractors shall ensure that all lower tier subcontracts or agreements with DBEs to supply labor or materials be performed in accordance with this Special Provision.

(d) ALTERNATIVE WORK METHODS. In addition to the above requirements for reductions in the condition of award, additional requirements apply to the two cases of Contractor-initiated work substitution proposals. Where the contract allows alternate work methods which serve to delete or create underruns in condition of award DBE work, and the Contractor selects that alternate method or, where the Contractor proposes a substitute work method or material that serves to diminish or delete work committed to a DBE and replace it with other work, then the Contractor must demonstrate one of the following:

(1) The replacement work will be performed by the same DBE (as long as the DBE is certified in the respective item of work) in a modification of the condition of award; or

(2) The DBE is aware its work will be deleted or will experience underruns and has agreed in writing to the change. If this occurs, the Contractor shall substitute other work of equivalent value to a certified DBE or provide documentation of good faith efforts to do so; or

(3) The DBE is not capable of performing the replacement work or has declined to perform the work at a reasonable competitive price. If this occurs, the Contractor shall substitute other work of equivalent value to a certified DBE or provide documentation of good faith efforts to do so.

(e) TERMINATION AND REPLACEMENT PROCEDURES. The Contractor shall not terminate or replace a DBE listed on the approved Utilization Plan, or perform with other forces work designated for a listed DBE except as provided in this Special Provision. The Contractor shall utilize the specific DBEs listed to perform the work and supply the materials for which each is listed unless the Contractor obtains the Department's written consent as provided in subsection (a) of this part. Unless Department consent is provided for termination of a DBE subcontractor, the Contractor shall not be entitled to any payment for work or material unless it is performed or supplied by the DBE in the Utilization Plan.

As stated above, the Contractor shall not terminate or replace a DBE subcontractor listed in the approved Utilization Plan without prior written consent. This includes, but is not limited to, instances in which the Contractor seeks to perform work originally designated for a DBE subcontractor with its own forces or those of an affiliate, a non-DBE firm, or with another DBE firm. Written consent will be granted only if the Bureau of Small Business Enterprises agrees, for reasons stated in its concurrence document, that the Contractor has good cause to terminate or replace the DBE firm. Before transmitting to the Bureau of Small Business Enterprises any request to terminate and/or substitute a DBE subcontractor, the Contractor shall give notice in writing to the DBE subcontractor, with a copy to the Bureau, of its intent to request to terminate and/or substitute, and the reason for the request. The Contractor shall give the DBE five days to respond to the Contractor's notice. The DBE so notified shall advise the Bureau and the Contractor of the reasons, if any, why it objects to the proposed termination of its subcontract and why the Bureau should not approve the Contractor's action. If required in a particular case as a matter of public necessity, the Bureau may provide a response period shorter than five days.

For purposes of this paragraph, good cause includes the following circumstances:

- (1) The listed DBE subcontractor fails or refuses to execute a written contract;
- (2) The listed DBE subcontractor fails or refuses to perform the work of its subcontract in a way consistent with normal industry standards. Provided, however, that good cause does not exist if the failure or refusal of the DBE subcontractor to perform its work on the subcontract results from the bad faith or discriminatory action of the Contractor;
- (3) The listed DBE subcontractor fails or refuses to meet the Contractor's reasonable, nondiscriminatory bond requirements;
- (4) The listed DBE subcontractor becomes bankrupt, insolvent, or exhibits credit unworthiness;
- (5) The listed DBE subcontractor is ineligible to work on public works projects because of suspension and debarment proceedings pursuant 2 CFR Parts 180, 215 and 1200 or applicable state law.
- (6) The Contractor has determined the listed DBE subcontractor is not a responsible contractor;
- (7) The listed DBE subcontractor voluntarily withdraws from the projects and provides written notice to the Contractor of its withdrawal;
- (8) The listed DBE is ineligible to receive DBE credit for the type of work required;
- (9) A DBE owner dies or becomes disabled with the result that the listed DBE subcontractor is unable to complete its work on the contract;
- (10) Other documented good cause that compels the termination of the DBE subcontractor. Provided, that good cause does not exist if the Contractor seeks to terminate a DBE it relied upon to obtain the contract so that the Contractor can self-perform the work for which the DBE contractor was engaged or so that the Contractor can substitute another DBE or non-DBE contractor after contract award.

When a DBE is terminated or fails to complete its work on the Contract for any reason, the Contractor shall make a good faith effort to find another DBE to substitute for the original DBE to perform at least the same amount of work under the contract as the terminated DBE to the extent needed to meet the established Contract goal. The good faith efforts shall be documented by the Contractor. If the Department requests documentation under this provision, the Contractor shall submit the documentation within seven days, which may be extended for an additional seven days if necessary at the request of the Contractor. The Department will provide a written determination to the Contractor stating whether or not good faith efforts have been demonstrated.

(f) FINAL PAYMENT. After the performance of the final item of work or delivery of material by a DBE and final payment therefore to the DBE by the Contractor, but not later than 30 calendar days after payment has been made by the Department to the Contractor for such work or material, the Contractor shall submit a DBE Payment Agreement on Department form SBE 2115 to the Resident Engineer. If full and final payment has not been made to the DBE, the DBE Payment Agreement shall indicate whether a disagreement as to the payment required exists between the Contractor and the DBE or if the Contractor believes the work has not been satisfactorily

completed. If the Contractor does not have the full amount of work indicated in the Utilization Plan performed by the DBE companies indicated in the Utilization Plan and after good faith efforts are reviewed, the Department may deduct from contract payments to the Contractor the amount of the goal not achieved as liquidated and ascertained damages. The Contractor may request an administrative reconsideration of any amount deducted as damages pursuant to subsection (h) of this part.

(g) **ENFORCEMENT.** The Department reserves the right to withhold payment to the Contractor to enforce the provisions of this Special Provision. Final payment shall not be made on the contract until such time as the Contractor submits sufficient documentation demonstrating achievement of the goal in accordance with this Special Provision or after liquidated damages have been determined and collected.

(h) **RECONSIDERATION.** Notwithstanding any other provision of the contract, including but not limited to Article 109.09 of the Standard Specifications, the Contractor may request administrative reconsideration of a decision to deduct the amount of the goal not achieved as liquidated damages. A request to reconsider shall be delivered to the Contract Compliance Section and shall be handled and considered in the same manner as set forth in paragraph (c) of "Good Faith Effort Procedures" of this Special Provision, except a final decision that a good faith effort was not made during contract performance to achieve the goal agreed to in the Utilization Plan shall be the final administrative decision of the Department. The result of the reconsideration process is not administratively appealable to the U.S. Department of Transportation.

SPECIAL PROVISION FOR WEEKLY DBE TRUCKING REPORTS (BDE)

Effective: June 2, 2012

Revised: April 2, 2015

The Contractor shall submit a weekly report of Disadvantaged Business Enterprise (DBE) trucks hired by the Contractor or subcontractors (i.e. not owned by the Contractor or subcontractors) that are used for DBE goal credit.

The report shall be submitted to the Resident Engineer on Division of Aeronautics Form "AER 723" within ten business days following the reporting period. The reporting period shall be Monday through Sunday for each week reportable trucking activities occur.

Any costs associated with providing weekly DBE trucking reports shall be considered as included in the contract unit prices bid for the various items of work involved and no additional compensation will be allowed.

SPECIAL PROVISION FOR SUBCONTRACTOR MOBILIZATION PAYMENTS

Effective: November 2, 2017

Revised: April 1, 2019

To account for the preparatory work and the operations necessary for the movement of subcontractor personnel, equipment, supplies, and incidentals to the project site and for all other work or operations that must be performed or costs incurred when beginning work approved for subcontracting according to Section 80-01 of the Standard Specifications, the Contractor shall make a mobilization payment to each subcontractor.

This mobilization payment shall be made at least seven days prior to the subcontractor starting work. The amount paid shall be at the following percentage of the amount of the subcontract reported on form AER 260A submitted for the approval of the subcontractor's work.

Value of Subcontract Reported on Form AER 260A	Mobilization Percentage
Less than \$10,000	25%
\$10,000 to less than \$20,000	20%
\$20,000 to less than \$40,000	18%
\$40,000 to less than \$60,000	16%
\$60,000 to less than \$80,000	14%
\$80,000 to less than \$100,000	12%
\$100,000 to less than \$250,000	10%
\$250,000 to less than \$500,000	9%
\$500,000 to \$750,000	8%
Over \$750,000	7%

The mobilization payment to the subcontractor is an advance payment of the reported amount of the subcontract and is not a payment in addition to the amount of the subcontract; therefore, the amount of the advance payment will be deducted from future progress payments.

This provision shall be incorporated directly or by reference into each subcontract approved by the Department.

SPECIAL PROVISION FOR PAYMENTS TO SUBCONTRACTORS

Effective: November 2, 2017

Federal regulations found at 49 CFR §26.29 mandate the Department to establish a contract clause to require Contractors to pay subcontractors for satisfactory performance of their subcontracts and to set the time for such payments.

State law also addresses the timing of payments to be made to subcontractors and material suppliers. Section 7 of the Prompt Payment Act, 30 ILCS 540/7, requires that when a Contractor receives any payment from the Department, the Contractor shall make corresponding, proportional payments to each subcontractor and material supplier performing work or supplying material within 15 calendar days after receipt of the Department payment. Section 7 of the Act further provides that interest in the amount of two percent per month, in addition to the payment due, shall be paid to any subcontractor or material supplier by the Contractor if the payment required by the Act is withheld or delayed without reasonable cause. The Act also provides that the time for payment required and the calculation of any interest due applies to transactions between subcontractors and lower-tier subcontractors and material suppliers throughout the contracting chain.

This Special Provision establishes the required federal contract clause, and adopts the 15 calendar day requirement of the State Prompt Payment Act for purposes of compliance with the federal regulation regarding payments to subcontractors. This contract is subject to the following payment obligations.

When progress payments are made to the Contractor according to Article 90-07 of the Standard Specifications, the Contractor shall make a corresponding payment to each subcontractor and material supplier in proportion to the work satisfactorily completed by each subcontractor and for the material supplied to perform any work of the contract. The proportionate amount of partial payment due to each subcontractor and material supplier throughout the contracting chain shall be determined by the quantities measured or otherwise determined as eligible for payment by the Department and included in the progress payment to the Contractor. Subcontractors and material suppliers shall be paid by the Contractor within 15 calendar days after the receipt of payment from the Department. The Contractor shall not hold retainage from the subcontractors. These obligations shall also apply to any payments made by subcontractors and material suppliers to their subcontractors and material suppliers; and to all payments made to lower tier subcontractors and material suppliers throughout the contracting chain. Any payment or portion of a payment subject to this provision may only be withheld from the subcontractor or material supplier to whom it is due for reasonable cause. If reasonable cause is asserted, written notice shall be provided to the applicable subcontractor and/or material supplier and the Engineer within five days of the Contractor receiving payment. The written notice shall identify the contract number, the subcontract or material purchase agreement, a detailed reason for refusal, the value of payment being withheld, and the specific remedial actions required of the subcontractor and/or material supplier so that payment can be made.

This Special Provision does not create any rights in favor of any subcontractor or material supplier against the State or authorize any cause of action against the State on account of any payment, nonpayment, delayed payment, or interest claimed by application of the State Prompt Payment Act. The Department will not approve any delay or postponement of the 15 day requirement except for reasonable cause shown after notice and hearing pursuant to Section 7(b) of the State Prompt Payment Act. State law creates other and additional remedies available to any subcontractor or material supplier, regardless of tier, who has not been paid for work properly performed or material furnished. These remedies are a lien against public funds set forth in Section 23(c) of the Mechanics Lien Act, 770 ILCS 60/23(c), and a recovery on the Contractor's payment bond according to the Public Construction Bond Act, 30 ILCS 550.

SPECIAL PROVISION FOR SUBCONTRACTOR AND DBE PAYMENT REPORTING (BDE)

Effective: April 2, 2018

Subcontractor and Disadvantaged Business Enterprise Payment Reporting

The Contractor shall report all payments made to the following parties:

- (a) first tier subcontractors;
- (b) lower tier subcontractors affecting disadvantaged business enterprise (DBE) goal credit;
- (c) material suppliers or trucking firms that are part of the Contractor's submitted DBE utilization plan.

The report shall be made through the Department's on-line subcontractor payment reporting system within 21 days of making the payment.

SPECIAL PROVISION FOR ADDITIONAL STATE REQUIREMENTS FOR FEDERAL-AID CONSTRUCTION CONTRACTS

Effective: February 1, 1969

Revised: January 1, 2017

EQUAL EMPLOYMENT OPPORTUNITY

In the event of the Contractor's noncompliance with the provisions of this Equal Employment Opportunity Clause, the Illinois Human Rights Act, or the Illinois Department of Human Rights Rules and Regulations, the Contractor may be declared ineligible for future contracts or subcontracts with the State of Illinois or any of its political sub-divisions or municipal corporations, and the contract may be cancelled or voided in whole or in part, and such other sanctions or penalties may be imposed or remedies invoked as provided by statute or regulation.

During the performance of this Contract, the Contractor agrees as follows:

- (1) That it will not discriminate against any employee or applicant for employment because of race, color, religion, sex, sexual orientation, marital status, order of protection status, national origin or ancestry, citizenship status, age, physical or mental disability

unrelated to ability, military status, or an unfavorable discharge from military service; and further that it will examine all job classifications to determine if minority persons or women are underutilized and will take appropriate affirmative action to rectify any such underutilization.

(2) That, if it hires additional employees in order to perform this contract or any portion hereof, it will determine the availability (in accordance with the Illinois Department of Human Rights Rules and Regulations) of minorities and women in the area(s) from which it may reasonably recruit and it will hire for each job classification for which employees are hired in such a way that minorities and women are not underutilized.

(3) That, in all solicitations or advertisements for employees placed by it or on its behalf, it will state that all applicants will be afforded equal opportunity without discrimination because of race, color, religion, sex, sexual orientation, marital status, order of protection status, national origin or ancestry, citizenship status, age, physical or mental disability unrelated to ability, military status, or an unfavorable discharge from military service.

(4) That it will send to each labor organization or representative of workers with which it has or is bound by a collective bargaining or other agreement or understanding, a notice advising such labor organization or representative of the Contractor's obligations under the Illinois Human Rights Act and the Illinois Department of Human Rights Rules and Regulations. If any labor organization or representative fails or refuses to cooperate with the Contractor in its efforts to comply with such Act and Rules and Regulations, the Contractor will promptly so notify the Illinois Department of Human Rights and IDOT and will recruit employees from other sources when necessary to fulfill its obligations thereunder.

(5) That it will submit reports as required by the Illinois Department of Human Rights Rules and Regulations, furnish all relevant information as may from time to time be requested by the Illinois Department of Human Rights or IDOT, and in all respects comply with the Illinois Human Rights Act and the Illinois Department of Human Rights Rules and Regulations.

(6) That it will permit access to all relevant books, records, accounts, and work sites by personnel of IDOT and the Illinois Department of Human Rights for purposes of investigation to ascertain compliance with the Illinois Human Rights Act and the Illinois Department of Human Rights Rules and Regulations.

(7) That it will include verbatim or by reference the provisions of this clause in every subcontract it awards under which any portion of the contract obligations are undertaken or assumed, so that the provisions will be binding upon the subcontractor. In the same manner as with other provisions of this contract, the Contractor will be liable for compliance with applicable provisions of this clause by subcontractors; and further it will promptly notify IDOT and the Illinois Department of Human Rights in the event any subcontractor fails or refuses to comply with these provisions. In addition, the Contractor will not utilize any subcontractor declared by the Illinois Human Rights Commission to be ineligible for contracts or subcontracts with the State of Illinois or any of its political subdivisions or municipal corporations.

SPECIAL PROVISION FOR NPDES CERTIFICATION

In accordance with the provisions of the Illinois Environmental Protection Act, the Illinois Pollution Control Board Rules and Regulations (35 Ill. Adm. Code, Subtitle C, Chapter I), and the Clean Water Act, and the regulations thereunder, this certification is required for all construction contracts that will result in the disturbance of one or more acres total land area.

The bidder certifies under penalty of law that he/she understands the terms and conditions of the general National Pollutant Discharge Elimination System (NPDES) permit (ILR100000) that authorizes the storm water discharges associated with industrial activity from the construction site identified as part of this certification.

The Airport Owner or its Agent will:

- 1) prepare, sign and submit the Notice of Intent (NOI)
- 2) conduct site inspections and complete and file the inspection reports
- 3) submit Incidence of Non-Compliance (ION) forms
- 4) submit Notice of Termination (NOT) form

Prior to the issuance of the Notice-to-Proceed, for each erosion control measure identified in the Storm Water Pollution Prevention Plan, the contractor or subcontractor responsible for the control measure(s) must sign the above certification (forms to be provided by the Department).

SPECIAL PROVISION FOR COMPLETION TIME VIA CALENDAR DAYS

It being understood and agreed that the completion within the time limit is an essential part of the contract, the bidder agrees to complete the work within Base Bid: 34 calendar days; Additive Alternate #1: 1 additional calendar day; Additive Alternate #2: 2 additional calendar days, unless additional time is granted by the Engineer in accordance with the provisions of the specifications. In

case of failure to complete the work on or before the time named herein, or within such extra time as may have been allowed by extensions, the bidder agrees that the Department of Transportation shall withhold from such sum as may be due him/her under the terms of this contract, the costs, as set forth in Section 80-09 Failure to Complete on Time of the Standard Specifications, which costs shall be considered and treated not as a penalty but as damages due to the State from the bidder by reason of the failure of the bidder to complete the work within the time specified in the contract.

State of Illinois
Department of Transportation

SPECIAL PROVISION
FOR
SECTION 80 PROSECUTION AND PROGRESS

This Special Provision amends the provisions of the Standard Specifications for Construction of Airports, adopted April 1, 2012 and shall be construed to be a part thereof, superseding any conflicting provisions thereof applicable to the work under the contract.

80-09 FAILURE TO COMPLETE ON TIME.

DELETE: "See contract documents for current schedule of deductions."

ADD:

Schedule of Deductions for Each Day of Overrun in Contract Time			
Original Contract Amount		Daily Charges	
From More Than	To and Including	Calendar Day	Work Day
\$ 0	\$ 100,000	\$ 475	\$ 675
100,000	500,000	750	1,050
500,000	1,000,000	1,025	1,425
1,000,000	3,000,000	1,275	1,725
3,000,000	6,000,000	1,425	2,000
6,000,000	12,000,000	2,300	3,450
12,000,000	And over	6,775	9,525

State of Illinois
Department of Transportation

SPECIAL PROVISION
FOR
SECTION 90 MEASUREMENT AND PAYMENT

This Special Provision amends the provisions of the Standard Specifications for Construction of Airports, adopted April 1, 2012 and shall be construed to be a part thereof, superseding any conflicting provisions thereof applicable to the work under the contract.

90-07 PARTIAL PAYMENTS.

DELETE: The entire section.

ADD: Partial payments will be made to the Contractor at least once each month as the work progresses. The payments will be based upon estimates, prepared by the Resident Engineer, of the value of the work performed and materials complete and in place in accordance with the contract, plans, and specifications. Such partial payments may also include the delivered actual cost of those materials stockpiled and stored in accordance with the Section 90-08 PAYMENT FOR MATERIALS ON HAND. From the amount of partial payment so determined on Federal-Aid projects, there shall be deducted an amount up to ten percent of the cost of the completed work which shall be retained until all conditions necessary for financial closeout of the project are satisfied. The amount of the estimate approved as due for payment will be vouchered by the Department and presented to the State Comptroller for payment. No amount less than \$1,000.00 will be approved for payment other than the final payment. A final voucher for under \$5.00 shall not be paid except through electronic funds transfer. (15 ILCS 405/9(b-1))

It is understood and agreed that the Contractor shall not be entitled to demand or receive partial payment based on quantities of work in excess of those provided in the proposal or covered by approved change orders, except when such excess quantities have been determined by the Engineer to be a part of the final quantity for the item of work in question.

No partial payment shall bind the Department to the acceptance of any materials or work in place as to quality or quantity. All partial payments are subject to correction at the time of final payment as provided in Section 90-09 ACCEPTANCE AND FINAL PAYMENT.

Progress payments may be reduced by liens filed pursuant to Section 23(c) of the Mechanics Lien Act, 770 ILCS 60/23(c).

If a Contractor or subcontractor has defaulted on a loan issued under the Department's Disadvantaged Business Revolving Loan Program (20 ILCS 2705/2705-610) progress payments may be reduced pursuant to the terms of that loan agreement. In such cases, the amount of the estimate related to the work performed by the Contractor or subcontractor, in default of the loan agreement, will be offset, in whole or in part, and vouchered by the Department to the Working Capital Revolving Fund or designated escrow account. Payment for the work shall be considered as issued and received by the Contractor or subcontractor on the date of the offset voucher. Further, the amount of the offset voucher shall be a credit against the Department's obligation to pay the Contractor, the Contractor's obligation to pay the subcontractor, and the Contractor's or subcontractor's total loan indebtedness to the Department. The offset shall continue until such time as the entire loan indebtedness is satisfied. The Department will notify the Contractor and Fund Control Agent in a timely manner of such offset. The Contractor or subcontractor shall not be entitled to additional payment in consideration of the offset.

In accordance with 49 USC § 47111, the Department will not make payments totaling more than 90 percent of the contract until all conditions necessary for financial closeout of the project are satisfied.

The failure to perform any requirement, obligation, or term of the contract by the Contractor shall be reason for withholding any progress payments until the Department determines that compliance has been achieved.

90-10 TRUST AGREEMENT OPTION.

DELETE: The entire section.

APPENDIX A – FEDERAL AVIATION ADMINISTRATION (FAA) REQUIRED CONTRACT PROVISIONS

A1 ACCESS TO RECORDS AND REPORTS

A1.1 CONTRACT CLAUSE

ACCESS TO RECORDS AND REPORTS

The Contractor must maintain an acceptable cost accounting system. The Contractor agrees to provide the sponsor, the Federal Aviation Administration, and the Comptroller General of the United States or any of their duly authorized representatives, access to any books, documents, papers, and records of the contractor which are directly pertinent to the specific contract for the purpose of making audit, examination, excerpts and transcriptions. The Contractor agrees to maintain all books, records and reports required under this contract for a period of not less than three years after final payment is made and all pending matters are closed.

A2 AFFIRMATIVE ACTION REQUIREMENTS

A2.1 SOLICITATION CLAUSE

NOTICE OF REQUIREMENT FOR AFFIRMATIVE ACTION TO ENSURE EQUAL EMPLOYMENT OPPORTUNITY

1. The Offeror's or Bidder's attention is called to the "Equal Opportunity Clause" and the "Standard Federal Equal Employment Opportunity Construction Contract Specifications" set forth herein.
2. The goals and timetables for minority and female participation, expressed in percentage terms for the contractor's aggregate workforce in each trade on all construction work in the covered area, are as follows:

The following goal for female utilization in each construction craft and trade shall apply to all Contractors holding Federal and federally-assisted construction contracts and subcontracts in excess of \$10,000. The goal is applicable to the Contractor's total on-site construction workforce, regardless of whether or not part of that workforce is performing work on a Federal, federally assisted or nonfederally related construction contract or subcontract.

AREA COVERED (STATEWIDE)

Goals for Women apply nationwide.

GOAL

Goal (percent)

Female Utilization..... 6.9

Until further notice, the following goals for minority utilization in each construction craft and trade shall apply to all Contractors holding Federal and federally-assisted construction contracts and subcontracts in excess of \$10,000 to be performed in the respective geographical areas. The goals are applicable to the Contractor's total on-site construction workforce, regardless of whether or not part of that workforce is performing work on a Federal, federally-assisted or nonfederally related construction contract or subcontract.

<u>Economic Area (percent)</u>	Goal
056 Paducah, KY: Non-SMSA Counties - IL - Hardin, Massac, Pope KY - Ballard, Caldwell, Calloway, Carlisle, Crittenden, Fulton, Graves, Hickman, Livingston, Lyon, McCracken, Marshall	5.2
080 Evansville, IN: Non-SMSA Counties - IL - Edwards, Gallatin, Hamilton, Lawrence, Saline, Wabash, White IN - Dubois, Knox, Perry, Pike, Spencer KY - Hancock, Hopkins, McLean, Mublenberg, Ohio, Union, Webster	3.5
081 Terre Haute, IN: Non-SMSA Counties - IL - Clark, Crawford IN - Parke	2.5
083 Chicago, IL: SMSA Counties: 1600 Chicago, IL - IL - Cook, DuPage, Kane, Lake, McHenry, Will	19.6

3740 Kankakee, IL - IL - Kankakee	9.1
Non-SMSA Counties IL - Bureau, DeKalb, Grundy, Iroquois, Kendall, LaSalle, Livingston, Putnam IN - Jasper, Laporte, Newton, Pulaski, Starke	18.4
084 Champaign - Urbana, IL: SMSA Counties: 1400 Champaign - Urbana - Rantoul, IL - IL - Champaign	7.8
Non-SMSA Counties - IL - Coles, Cumberland, Douglas, Edgar, Ford, Piatt, Vermilion	4.8
085 Springfield - Decatur, IL: SMSA Counties: 2040 Decatur, IL - IL - Macon	7.6
7880 Springfield, IL - IL - Menard, Sangamon	4.5
Non-SMSA Counties IL - Cass, Christian, Dewitt, Logan, Morgan, Moultrie, Scott, Shelby	4.0
086 Quincy, IL: Non-SMSA Counties	3.1
IL - Adams, Brown, Pike MO - Lewis, Marion, Pike, Ralls	
087 Peoria, IL: SMSA Counties: 1040 Bloomington - Normal, IL - IL - McLean	2.5
6120 Peoria, IL - IL - Peoria, Tazewell, Woodford	4.4
Non-SMSA Counties - IL - Fulton, Knox, McDonough, Marshall, Mason, Schuyler, Stark, Warren	3.3
088 Rockford, IL: SMSA Counties: 6880 Rockford, IL - IL - Boone, Winnebago	6.3
Non-SMSA Counties - IL - Lee, Ogle, Stephenson	4.6
098 Dubuque, IA: Non-SMSA Counties - IL - JoDaviess IA - Atlamakee, Clayton, Delaware, Jackson, Winnesheik WI - Crawford, Grant, Lafayette	0.5
099 Davenport, Rock Island, Moline, IA - IL: SMSA Counties: 1960 Davenport, Rock Island, Moline, IA - IL - IL - Henry, Rock Island IA - Scott	4.6
Non-SMSA Counties - IL - Carroll, Hancock, Henderson, Mercer, Whiteside IA - Clinton, DesMoines, Henry, Lee, Louisa, Muscatine MO - Clark	3.4
107 St. Louis, MO: SMSA Counties: 7040 St. Louis, MO - IL - IL - Clinton, Madison, Monroe, St. Clair MO - Franklin, Jefferson, St. Charles, St. Louis, St. Louis City	14.7
Non-SMSA Counties - IL - Alexander, Bond, Calhoun, Clay, Effingham, Fayette, Franklin, Greene,	11.4

Jackson, Jasper, Jefferson, Jersey, Johnson, Macoupin, Marion,
Montgomery, Perry, Pulaski, Randolph, Richland, Union, Washington,
Wayne, Williamson
MO - Bollinger, Butler, Cape Girardeau, Carter, Crawford, Dent, Gasconade,
Iron, Lincoln, Madison, Maries, Mississippi, Montgomery, Perry, Phelps,
Reynolds, Ripley, St. Francois, St. Genevieve, Scott, Stoddard, Warren,
Washington, Wayne

These goals are applicable to all of the contractor's construction work (whether or not it is Federal or federally-assisted) performed in the covered area. If the contractor performs construction work in a geographical area located outside of the covered area, it shall apply the goals established for such geographical area where the work is actually performed. With regard to this second area, the contractor also is subject to the goals for both its federally involved and non-federally involved construction.

The Contractor's compliance with the Executive Order and the regulations in 41 CFR Part 60-4 shall be based on its implementation of the Equal Opportunity Clause, specific affirmative action obligations required by the specifications set forth in 41 CFR 60-4.3(a), and its efforts to meet the goals. The hours of minority and female employment and training must be substantially uniform throughout the length of the contract, and in each trade, and the contractor shall make a good faith effort to employ minorities and women evenly on each of its projects. The transfer of minority or female employees or trainees from Contractor to Contractor or from project to project for the sole purpose of meeting the Contractor's goals shall be a violation of the contract, the Executive Order and the regulations in 41 CFR Part 60-4. Compliance with the goals will be measured against the total work hours performed.

3. The Contractor shall provide written notification to the Director of the Office of Federal Contract Compliance Programs (OFCCP) within 10 working days of award of any construction subcontract in excess of \$10,000 at any tier for construction work under the contract resulting from this solicitation. The notification shall list the name, address, and telephone number of the subcontractor; employer identification number of the subcontractor; estimated dollar amount of the subcontract; estimated starting and completion dates of the subcontract; and the geographical area in which the subcontract is to be performed.

4. As used in this notice and in the contract resulting from this solicitation, the "covered area" is Aurora, Illinois; Kane County.

A3 BREACH OF CONTRACT TERMS

A3.1 CONTRACT CLAUSE

This provision is required for all contracts that exceed the simplified acquisition threshold as stated in 2 CFR Part 200, Appendix II (A). This threshold is occasionally adjusted for inflation and is now equal to \$150,000.

BREACH OF CONTRACT TERMS

Any violation or breach of terms of this contract on the part of the contractor or its subcontractors may result in the suspension or termination of this contract or such other action that may be necessary to enforce the rights of the parties of this agreement.

Owner will provide the Contractor written notice that describes the nature of the breach and corrective actions the Contractor must undertake in order to avoid termination of the contract. Owner reserves the right to withhold payments to Contractor until such time the Contractor corrects the breach or the Owner elects to terminate the contract. The Owner's notice will identify a specific date by which the Contractor must correct the breach. Owner may proceed with termination of the contract if the Contractor fails to correct the breach by deadline indicated in the Owner's notice.

The duties and obligations imposed by the Contract Documents and the rights and remedies available thereunder are in addition to, and not a limitation of, any duties, obligations, rights and remedies otherwise imposed or available by law.

A4 BUY AMERICAN PREFERENCE

A4.1 CONTRACT CLAUSE

- (a) The Aviation Safety and Capacity Expansion Act of 1990 provides that preference be given to steel and manufactured products produced in the United States when funds are expended pursuant to a grant issued under the Airport Improvement Program (AIP).
- (b) Any and all steel products used in the performance of this contract by the Contractor, subcontractors, producers, and suppliers are required to adhere to the Illinois Steel Products Procurement Act, which requires that all steel items be of 100 percent domestic origin and manufacture. Any products listed under the Federal Aviation Administration's (FAA) nationwide approved list of "Equipment Meeting Buy American Requirements" shall be deemed as meeting the requirements of the Illinois Steel Products Procurement Act.
- (c) The successful bidder will be required to assure that only domestic steel and domestically manufactured products will be used by the Contractor, subcontractors, producers, and suppliers in the performance of this contract. The North American Free Trade Agreement (NAFTA) specifically excluded federal grant programs such as the AIP. Therefore, NAFTA does not change the requirement to comply with the Buy American requirement in the Act. Exceptions to this are for products, other than steel, that:
 - (1) the FAA has determined, under the Aviation Safety and Capacity Expansion Act of 1990, are not produced in the United States in sufficient and reasonably available quantities or of a satisfactory quality;
 - (2) the FAA has determined, under the Aviation Safety and Capacity Expansion Act of 1990, that domestic preference would be inconsistent with the public interest;

- (3) the FAA has determined that inclusion of domestic material will increase the cost of the overall project contract by more than 25 percent; or
- (4) the FAA has determined, under the Aviation Safety and Capacity Expansion Act of 1990,
 - (i) the cost of components and subcomponents produced in the United States is more than 60 percent of the cost of all components of the facility or equipment, and
 - (ii) final assembly of the facility or equipment has occurred in the United States.

The FAA must grant waivers for any items that are included in these above exceptions. Bidders can review items already approved under the FAA nationwide approved list of "Equipment Meeting Buy American Requirements" on the FAA website, which do not require a specific FAA waiver.

All waivers are the responsibility of the Contractor, must be obtained prior to the Notice to Proceed, and must be submitted to the Illinois Division of Aeronautics for review and approval before being forwarded to the FAA. Any products used on the project that cannot meet the domestic requirement, and for which a waiver prior to the Notice to Proceed was not obtained, will be rejected for use and subject to removal and replacement with no additional compensation, and the contractor deemed non-responsive.

A5 CIVIL RIGHTS - GENERAL

A5.1 CONTRACT CLAUSE

GENERAL CIVIL RIGHTS PROVISIONS

The contractor agrees to comply with pertinent statutes, Executive Orders and such rules as are promulgated to ensure that no person shall, on the grounds of race, creed, color, national origin, sex, age, or disability be excluded from participating in any activity conducted with or benefiting from Federal assistance.

This provision binds the contractor and subtier contractors from the bid solicitation period through the completion of the contract. This provision is in addition to that required of Title VI of the Civil Rights Act of 1964.

A6 CIVIL RIGHTS – TITLE VI ASSURANCE

A6.1 CONTRACT CLAUSE

A6.1.1 Title VI Solicitation Notice

Title VI Solicitation Notice:

The City of Aurora, in accordance with the provisions of Title VI of the Civil Rights Act of 1964 (78 Stat. 252, 42 U.S.C. §§ 2000d to 2000d-4) and the Regulations, hereby notifies all bidders that it will affirmatively ensure that any contract entered into pursuant to this advertisement, disadvantaged business enterprises will be afforded full and fair opportunity to submit bids in response to this invitation and will not be discriminated against on the grounds of race, color, or national origin in consideration for an award.

A6.1.2 Title VI Clauses for Compliance with Nondiscrimination Requirements

Compliance with Nondiscrimination Requirements

During the performance of this contract, the contractor, for itself, its assignees, and successors in interest (hereinafter referred to as the "contractor") agrees as follows:

Compliance with Regulations: The contractor (hereinafter includes consultants) will comply with the Title VI List of Pertinent Nondiscrimination Acts And Authorities, as they may be amended from time to time, which are herein incorporated by reference and made a part of this contract.

Non-discrimination: The contractor, with regard to the work performed by it during the contract, will not discriminate on the grounds of race, color, or national origin in the selection and retention of subcontractors, including procurements of materials and leases of equipment. The contractor will not participate directly or indirectly in the discrimination prohibited by the Nondiscrimination Acts and Authorities, including employment practices when the contract covers any activity, project, or program set forth in Appendix B of 49 CFR part 21.

Solicitations for Subcontracts, Including Procurements of Materials and Equipment: In all solicitations, either by competitive bidding, or negotiation made by the contractor for work to be performed under a subcontract, including procurements of materials, or leases of equipment, each potential subcontractor or supplier will be notified by the contractor of the contractor's obligations under this contract and the Nondiscrimination Acts And Authorities on the grounds of race, color, or national origin.

Information and Reports: The contractor will provide all information and reports required by the Acts, the Regulations, and directives issued pursuant thereto and will permit access to its books, records, accounts, other sources of information, and its facilities as may be determined by the sponsor or the Federal Aviation Administration to be pertinent to ascertain compliance with such Nondiscrimination Acts And Authorities and instructions. Where any information required of a contractor is in the exclusive possession of another who fails or refuses to furnish the information, the contractor will so certify to the sponsor or the Federal Aviation Administration, as appropriate, and will set forth what efforts it has made to obtain the information.

Sanctions for Noncompliance: In the event of a contractor's noncompliance with the Non-discrimination provisions of this contract, the sponsor will impose such contract sanctions as it or the Federal Aviation Administration may determine to be appropriate, including, but not limited to:

- a. Withholding payments to the contractor under the contract until the contractor complies; and/or
- b. Cancelling, terminating, or suspending a contract, in whole or in part.

Incorporation of Provisions: The contractor will include the provisions of paragraphs one through six in every subcontract, including procurements of materials and leases of equipment, unless exempt by the Acts, the Regulations and directives issued pursuant thereto. The contractor will take action with respect to any subcontract or procurement as the sponsor or the Federal Aviation Administration may direct as a means of enforcing such provisions including sanctions for noncompliance. Provided, that if the contractor becomes involved in, or is threatened with litigation by a subcontractor, or supplier because of such direction, the contractor may request the sponsor to enter into any litigation to protect the interests of the sponsor. In addition, the contractor may request the United States to enter into the litigation to protect the interests of the United States.

A6.1.3 Title VI List of Pertinent Nondiscrimination Acts and Authorities

Title VI List of Pertinent Nondiscrimination Acts and Authorities

During the performance of this contract, the contractor, for itself, its assignees, and successors in interest (hereinafter referred to as the "contractor") agrees to comply with the following non-discrimination statutes and authorities; including but not limited to:

- Title VI of the Civil Rights Act of 1964 (42 U.S.C. § 2000d *et seq.*, 78 stat. 252), (prohibits discrimination on the basis of race, color, national origin); 49 CFR part 21 (Non-discrimination In Federally-Assisted Programs of The Department of Transportation—Effectuation of Title VI of The Civil Rights Act of 1964);
- The Uniform Relocation Assistance and Real Property Acquisition Policies Act of 1970, (42 U.S.C. § 4601), (prohibits unfair treatment of persons displaced or whose property has been acquired because of Federal or Federal-aid programs and projects);
- Section 504 of the Rehabilitation Act of 1973, (29 U.S.C. § 794 *et seq.*), as amended, (prohibits discrimination on the basis of disability); and 49 CFR part 27;
- The Age Discrimination Act of 1975, as amended, (42 U.S.C. § 6101 *et seq.*), (prohibits discrimination on the basis of age);
- Airport and Airway Improvement Act of 1982, (49 USC § 471, Section 47123), as amended, (prohibits discrimination based on race, creed, color, national origin, or sex);
- The Civil Rights Restoration Act of 1987, (PL 100-209), (Broadened the scope, coverage and applicability of Title VI of the Civil Rights Act of 1964, The Age Discrimination Act of 1975 and Section 504 of the Rehabilitation Act of 1973, by expanding the definition of the terms "programs or activities" to include all of the programs or activities of the Federal-aid recipients, sub-recipients and contractors, whether such programs or activities are Federally funded or not);
- Titles II and III of the Americans with Disabilities Act of 1990, which prohibit discrimination on the basis of disability in the operation of public entities, public and private transportation systems, places of public accommodation, and certain testing entities (42 U.S.C. §§ 12131 – 12189) as implemented by Department of Transportation regulations at 49 CFR parts 37 and 38;
- The Federal Aviation Administration's Non-discrimination statute (49 U.S.C. § 47123) (prohibits discrimination on the basis of race, color, national origin, and sex);
- Executive Order 12898, Federal Actions to Address Environmental Justice in Minority Populations and Low-Income Populations, which ensures non-discrimination against minority populations by discouraging programs, policies, and activities with disproportionately high and adverse human health or environmental effects on minority and low-income populations;
- Executive Order 13166, Improving Access to Services for Persons with Limited English Proficiency, and resulting agency guidance, national origin discrimination includes discrimination because of limited English proficiency (LEP). To ensure compliance with Title VI, you must take reasonable steps to ensure that LEP persons have meaningful access to your programs (70 Fed. Reg. at 74087 to 74100);
- Title IX of the Education Amendments of 1972, as amended, which prohibits you from discriminating because of sex in education programs or activities (20 U.S.C. 1681 *et seq.*).

A7 CLEAN AIR AND WATER POLLUTION CONTROL

A7.1 CONTRACT CLAUSE

This provision is required for all contracts and lower tier contracts that exceed \$150,000.

CLEAN AIR AND WATER POLLUTION CONTROL

Contractor agrees to comply with all applicable standards, orders, and regulations issued pursuant to the Clean Air Act (42 U.S.C. § 740-7671q) and the Federal Water Pollution Control Act as amended (33 U.S.C. § 1251-1387). The Contractor agrees to report any violation to the Owner immediately upon discovery. The Owner assumes responsibility for notifying the Environmental Protection Agency (EPA) and the Federal Aviation Administration.

Contractor must include this requirement in all subcontracts that exceeds \$150,000.

A8 CONTRACT WORKHOURS AND SAFETY STANDARDS ACT REQUIREMENTS

A8.1 CONTRACT CLAUSE

This provision applies to all contracts and lower tier contracts that exceed \$100,000, and employ laborers, mechanics, watchmen, and guards.

CONTRACT WORKHOURS AND SAFETY STANDARDS ACT REQUIREMENTS

1. Overtime Requirements.

No contractor or subcontractor contracting for any part of the contract work which may require or involve the employment of laborers or mechanics shall require or permit any such laborer or mechanic, including watchmen and guards, in any workweek in which he or she is employed on such work to work in excess of forty hours in such workweek unless such laborer or mechanic receives compensation at a rate not less than one and one-half times the basic rate of pay for all hours worked in excess of forty hours in such workweek.

2. Violation; Liability for Unpaid Wages; Liquidated Damages.

In the event of any violation of the clause set forth in paragraph (1) of this clause, the contractor and any subcontractor responsible therefor shall be liable for the unpaid wages. In addition, such contractor and subcontractor shall be liable to the United States (in the case of work done under contract for the District of Columbia or a territory, to such District or to such territory), for liquidated damages. Such liquidated damages shall be computed with respect to each individual laborer or mechanic, including watchmen and guards, employed in violation of the clause set forth in paragraph (1) of this clause, in the sum of \$10 for each calendar day on which such individual was required or permitted to work in excess of the standard workweek of forty hours without payment of the overtime wages required by the clause set forth in paragraph (1) of this clause.

3. Withholding for Unpaid Wages and Liquidated Damages.

The Federal Aviation Administration (FAA) or the Owner shall upon its own action or upon written request of an authorized representative of the Department of Labor withhold or cause to be withheld, from any moneys payable on account of work performed by the contractor or subcontractor under any such contract or any other Federal contract with the same prime contractor, or any other Federally-assisted contract subject to the Contract Work Hours and Safety Standards Act, which is held by the same prime contractor, such sums as may be determined to be necessary to satisfy any liabilities of such contractor or subcontractor for unpaid wages and liquidated damages as provided in the clause set forth in paragraph 2 of this clause.

4. Subcontractors.

The contractor or subcontractor shall insert in any subcontracts the clauses set forth in paragraphs (1) through (4) and also a clause requiring the subcontractor to include these clauses in any lower tier subcontracts. The prime contractor shall be responsible for compliance by any subcontractor or lower tier subcontractor with the clauses set forth in paragraphs (1) through (4) of this clause.

A9 COPELAND "ANTI-KICKBACK" ACT

A9.1 CONTRACT CLAUSE

COPELAND "ANTI-KICKBACK" ACT

Contractor must comply with the requirements of the Copeland "Anti-Kickback" Act (18 U.S.C. 874 and 40 U.S.C. 3145), as supplemented by Department of Labor regulation 29 CFR part 3. Contractor and subcontractors are prohibited from inducing, by any means, any person employed on the project to give up any part of the compensation to which the employee is entitled. The Contractor and each Subcontractor must submit to the Owner, a weekly statement on the wages paid to each employee performing on covered work during the prior week. Owner must report any violations of the Act to the Federal Aviation Administration.

A10 DAVIS-BACON REQUIREMENTS

A10.1 CONTRACT CLAUSE

DAVIS-BACON REQUIREMENTS

1. Minimum Wages

(i) All laborers and mechanics employed or working upon the site of the work will be paid unconditionally and not less often than once a week, and without subsequent deduction or rebate on any account (except such payroll deductions as are permitted by the Secretary of Labor under the Copeland Act (29 CFR Part 3)), the full amount of wages and bona fide fringe benefits (or cash equivalent thereof) due at time of payment computed at rates not less than those contained in the wage determination of the Secretary of Labor which is attached hereto and made a part hereof, regardless of any contractual relationship which may be alleged to exist between the contractor and such laborers and mechanics.

Contributions made or costs reasonably anticipated for bona fide fringe benefits under section 1(b)(2) of the Davis-Bacon Act on behalf of laborers or mechanics are considered wages paid to such laborers or mechanics, subject to the provisions of paragraph (1)(iv) of this section; also, regular contributions made or costs incurred for more than a weekly period (but not less often than quarterly) under plans, funds, or programs which cover the particular weekly period, are deemed to be constructively made or incurred during such weekly period. Such laborers and mechanics shall be paid the appropriate wage rate and fringe benefits on the wage determination for the classification of work actually performed, without regard to skill, except as provided in 29 CFR Part 5.5(a)(4). Laborers or mechanics performing work in more than one classification may be compensated at the rate specified for each classification for the time actually worked therein: *Provided*, that the employer's payroll records accurately set forth the time spent in each classification in which work is performed. The wage determination (including any additional classification and wage rates conformed under (1)(ii) of this

section) and the Davis-Bacon poster (WH-1321) shall be posted at all times by the contractor and its subcontractors at the site of the work in a prominent and accessible place where it can easily be seen by the workers.

(ii)(A) The contracting officer shall require that any class of laborers or mechanics, including helpers, which is not listed in the wage determination and which is to be employed under the contract shall be classified in conformance with the wage determination. The contracting officer shall approve an additional classification and wage rate and fringe benefits therefore only when the following criteria have been met:

(1) The work to be performed by the classification requested is not performed by a classification in the wage determination; and

(2) The classification is utilized in the area by the construction industry; and

(3) The proposed wage rate, including any bona fide fringe benefits, bears a reasonable relationship to the wage rates contained in the wage determination.

(B) If the contractor and the laborers and mechanics to be employed in the classification (if known), or their representatives, and the contracting officer agree on the classification and wage rate (including the amount designated for fringe benefits where appropriate), a report of the action taken shall be sent by the contracting officer to the Administrator of the Wage and Hour Division, Employment Standards Administration, U.S. Department of Labor, Washington, D.C. 20210. The Administrator, or an authorized representative, will approve, modify, or disapprove every additional classification action within 30 days of receipt and so advise the contracting officer or will notify the contracting officer within the 30-day period that additional time is necessary.

(C) In the event the contractor, the laborers or mechanics to be employed in the classification or their representatives, and the contracting officer do not agree on the proposed classification and wage rate (including the amount designated for fringe benefits where appropriate), the contracting officer shall refer the questions, including the views of all interested parties and the recommendation of the contracting officer, to the Administrator for determination. The Administrator, or an authorized representative, will issue a determination within 30 days of receipt and so advise the contracting officer or will notify the contracting officer within the 30-day period that additional time is necessary.

(D) The wage rate (including fringe benefits where appropriate) determined pursuant to subparagraphs (1)(ii) (B) or (C) of this paragraph, shall be paid to all workers performing work in the classification under this contract from the first day on which work is performed in the classification.

(iii) Whenever the minimum wage rate prescribed in the contract for a class of laborers or mechanics includes a fringe benefit which is not expressed as an hourly rate, the contractor shall either pay the benefit as stated in the wage determination or shall pay another bona fide fringe benefit or an hourly cash equivalent thereof.

(iv) If the contractor does not make payments to a trustee or other third person, the contractor may consider as part of the wages of any laborer or mechanic the amount of any costs reasonably anticipated in providing bona fide fringe benefits under a plan or program, *Provided*, That the Secretary of Labor has found, upon the written request of the contractor, that the applicable standards of the Davis-Bacon Act have been met. The Secretary of Labor may require the contractor to set aside in a separate account assets for the meeting of obligations under the plan or program.

2 Withholding.

The Federal Aviation Administration or the sponsor shall upon its own action or upon written request of an authorized representative of the Department of Labor withhold or cause to be withheld from the contractor under this contract or any other Federal contract with the same prime contractor, or any other Federally-assisted contract subject to Davis-Bacon prevailing wage requirements, which is held by the same prime contractor, so much of the accrued payments or advances as may be considered necessary to pay laborers and mechanics, including apprentices, trainees, and helpers, employed by the contractor or any subcontractor the full amount of wages required by the contract. In the event of failure to pay any laborer or mechanic, including any apprentice, trainee, or helper, employed or working on the site of work, all or part of the wages required by the contract, the Federal Aviation Administration may, after written notice to the contractor, sponsor, applicant, or owner, take such action as may be necessary to cause the suspension of any further payment, advance, or guarantee of funds until such violations have ceased.

3. Payrolls and basic records.

(i) Payrolls and basic records relating thereto shall be maintained by the contractor during the course of the work and preserved for a period of three years thereafter for all laborers and mechanics working at the site of the work. Such records shall contain the name, address, and social security number of each such worker, his or her correct classification, hourly rates of wages paid (including rates of contributions or costs anticipated for bona fide fringe benefits or cash equivalents thereof of the types described in 1(b)(2)(B) of the Davis-Bacon Act), daily and weekly number of hours worked, deductions made and actual wages paid. Whenever the Secretary of Labor has found under 29 CFR 5.5(a)(1)(iv) that the wages of any laborer or mechanic include the amount of any costs reasonably anticipated in providing benefits under a plan or program described in section 1(b)(2)(B) of the Davis-Bacon Act, the contractor shall maintain records which show that the commitment to provide such benefits is enforceable, that the plan or program is financially responsible, and that the plan or program has been communicated in writing to the laborers or mechanics affected, and records which show the costs anticipated or the actual costs incurred in providing such benefits. Contractors employing apprentices or trainees under approved programs shall maintain written evidence of the registration of apprenticeship programs and certification of trainee programs, the registration of the apprentices and trainees, and the ratios and wage rates prescribed in the applicable programs.

(ii)(A) The contractor shall submit weekly for each week in which any contract work is performed a copy of all payrolls to the Federal Aviation Administration if the agency is a party to the contract, but if the agency is not such a party, the contractor will submit the payrolls to the applicant, sponsor, or owner, as the case may be, for transmission to the Federal Aviation Administration. The payrolls submitted shall set out accurately and completely all of the information required to be maintained under 29 CFR 5.5(a)(3)(i), except that full social security numbers and home addresses shall not be included on weekly transmittals. Instead the payrolls shall only need to include an individually identifying number for each employee (e.g., the last four digits of the employee's social security number). The required weekly payroll information may be submitted in any form desired. Optional Form WH-347 is available for this purpose from the Wage and Hour Division Web site at <http://www.dol.gov/esa/whd/forms/wh347instr.htm> or its successor site. The prime contractor is responsible for the submission of copies of payrolls by all subcontractors. Contractors and subcontractors shall maintain the full social security number and current address of each covered worker, and shall provide them upon request to the Federal Aviation

Administration if the agency is a party to the contract, but if the agency is not such a party, the contractor will submit them to the applicant, sponsor, or owner, as the case may be, for transmission to the Federal Aviation Administration, the contractor, or the Wage and Hour Division of the Department of Labor for purposes of an investigation or audit of compliance with prevailing wage requirements. It is not a violation of this section for a prime contractor to require a subcontractor to provide addresses and social security numbers to the prime contractor for its own records, without weekly submission to the sponsoring government agency (or the applicant, sponsor, or owner).

(B) Each payroll submitted shall be accompanied by a "Statement of Compliance," signed by the contractor or subcontractor or his or her agent who pays or supervises the payment of the persons employed under the contract and shall certify the following:

(1) That the payroll for the payroll period contains the information required to be provided under 29 CFR § 5.5(a)(3)(ii), the appropriate information is being maintained under 29 CFR § 5.5 (a)(3)(i) and that such information is correct and complete;

(2) That each laborer and mechanic (including each helper, apprentice and trainee) employed on the contract during the payroll period has been paid the full weekly wages earned, without rebate, either directly or indirectly, and that no deductions have been made either directly or indirectly from the full wages earned, other than permissible deductions as set forth in Regulations 29 CFR Part 3;

(3) That each laborer or mechanic has been paid not less than the applicable wage rates and fringe benefits or cash equivalents for the classification of work performed, as specified in the applicable wage determination incorporated into the contract.

(C) The weekly submission of a properly executed certification set forth on the reverse side of Optional Form WH-347 shall satisfy the requirement for submission of the "Statement of Compliance" required by paragraph (3)(ii)(B) of this section.

(D) The falsification of any of the above certifications may subject the contractor or subcontractor to civil or criminal prosecution under Section 1001 of Title 18 and Section 231 of Title 31 of the United States Code.

(iii) The contractor or subcontractor shall make the records required under paragraph (3)(i) of this section available for inspection, copying or transcription by authorized representatives of the sponsor, the Federal Aviation Administration or the Department of Labor, and shall permit such representatives to interview employees during working hours on the job. If the contractor or subcontractor fails to submit the required records or to make them available, the Federal agency may, after written notice to the contractor, sponsor, applicant or owner, take such action as may be necessary to cause the suspension of any further payment, advance, or guarantee of funds. Furthermore, failure to submit the required records upon request or to make such records available may be grounds for debarment action pursuant to 29 CFR 5.12.

4. Apprentices and Trainees.

(i) Apprentices. Apprentices will be permitted to work at less than the predetermined rate for the work they performed when they are employed pursuant to and individually registered in a bona fide apprenticeship program registered with the U.S. Department of Labor, Employment and Training Administration, Bureau of Apprenticeship and Training, or with a State Apprenticeship Agency recognized by the Bureau, or if a person is employed in his or her first 90 days of probationary employment as an apprentice in such an apprenticeship program, who is not individually registered in the program, but who has been certified by the Bureau of Apprenticeship and Training or a State Apprenticeship Agency (where appropriate) to be eligible for probationary employment as an apprentice. The allowable ratio of apprentices to journeymen on the job site in any craft classification shall not be greater than the ratio permitted to the contractor as to the entire work force under the registered program. Any worker listed on a payroll at an apprentice wage rate, who is not registered or otherwise employed as stated above, shall be paid not less than the applicable wage rate on the wage determination for the classification of work actually performed. In addition, any apprentice performing work on the job site in excess of the ratio permitted under the registered program shall be paid not less than the applicable wage rate on the wage determination for the work actually performed. Where a contractor is performing construction on a project in a locality other than that in which its program is registered, the ratios and wage rates (expressed in percentages of the journeyman's hourly rate) specified in the contractor's or subcontractor's registered program shall be observed. Every apprentice must be paid at not less than the rate specified in the registered program for the apprentice's level of progress, expressed as a percentage of the journeymen hourly rate specified in the applicable wage determination. Apprentices shall be paid fringe benefits in accordance with the provisions of the apprenticeship program. If the apprenticeship program does not specify fringe benefits, apprentices must be paid the full amount of fringe benefits listed on the wage determination for the applicable classification. If the Administrator determines that a different practice prevails for the applicable apprentice classification, fringes shall be paid in accordance with that determination. In the event the Bureau of Apprenticeship and Training, or a State Apprenticeship Agency recognized by the Bureau, withdraws approval of an apprenticeship program, the contractor will no longer be permitted to utilize apprentices at less than the applicable predetermined rate for the work performed until an acceptable program is approved.

(ii) Trainees. Except as provided in 29 CFR 5.16, trainees will not be permitted to work at less than the predetermined rate for the work performed unless they are employed pursuant to and individually registered in a program which has received prior approval, evidenced by formal certification by the U.S. Department of Labor, Employment and Training Administration. The ratio of trainees to journeymen on the job site shall not be greater than permitted under the plan approved by the Employment and Training Administration. Every trainee must be paid at not less than the rate specified in the approved program for the trainee's level of progress, expressed as a percentage of the journeyman hourly rate specified in the applicable wage determination. Trainees shall be paid fringe benefits in accordance with the provisions of the trainee program. If the trainee program does not mention fringe benefits, trainees shall be paid the full amount of fringe benefits listed on the wage determination unless the Administrator of the Wage and Hour Division determines that there is an apprenticeship program associated with the corresponding journeyman wage rate on the wage determination which provides for less than full fringe benefits for apprentices. Any employee listed on the payroll at a trainee rate that is not registered and participating in a training plan approved by the Employment and Training Administration shall be paid not less than the applicable wage rate on the wage determination for the classification of work actually performed. In addition, any trainee performing work on the job site in excess of the ratio permitted under the registered program shall be paid not less than the applicable wage rate on the wage determination for the work actually performed. In the event the Employment and Training Administration withdraws approval of a training program, the contractor will no longer be permitted to utilize trainees at less than the applicable predetermined rate for the work performed until an acceptable program is approved.

(iii) Equal Employment Opportunity. The utilization of apprentices, trainees and journeymen under this part shall be in conformity with the equal employment opportunity requirements of Executive Order 11246, as amended, and 29 CFR Part 30.

5. Compliance with Copeland Act Requirements.

The contractor shall comply with the requirements of 29 CFR Part 3, which are incorporated by reference in this contract.

6. Subcontracts.

The contractor or subcontractor shall insert in any subcontracts the clauses contained in 29 CFR Part 5.5(a)(1) through (10) and such other clauses as the Federal Aviation Administration may by appropriate instructions require, and also a clause requiring the subcontractors to include these clauses in any lower tier subcontracts. The prime contractor shall be responsible for the compliance by any subcontractor or lower tier subcontractor with all the contract clauses in 29 CFR Part 5.5.

7. Contract Termination: Debarment.

A breach of the contract clauses in paragraph 1 through 10 of this section may be grounds for termination of the contract, and for debarment as a contractor and a subcontractor as provided in 29 CFR 5.12.

8. Compliance With Davis-Bacon and Related Act Requirements.

All rulings and interpretations of the Davis-Bacon and Related Acts contained in 29 CFR Parts 1, 3, and 5 are herein incorporated by reference in this contract.

9. Disputes Concerning Labor Standards.

Disputes arising out of the labor standards provisions of this contract shall not be subject to the general disputes clause of this contract. Such disputes shall be resolved in accordance with the procedures of the Department of Labor set forth in 29 CFR Parts 5, 6 and 7. Disputes within the meaning of this clause include disputes between the contractor (or any of its subcontractors) and the contracting agency, the U.S. Department of Labor, or the employees or their representatives.

10. Certification of Eligibility.

(i) By entering into this contract, the contractor certifies that neither it (nor he or she) nor any person or firm who has an interest in the contractor's firm is a person or firm ineligible to be awarded Government contracts by virtue of section 3(a) of the Davis-Bacon Act or 29 CFR 5.12(a)(1).

(ii) No part of this contract shall be subcontracted to any person or firm ineligible for award of a Government contract by virtue of section 3(a) of the Davis-Bacon Act or 29 CFR 5.12(a)(1).

(iii) The penalty for making false statements is prescribed in the U.S. Criminal Code, 18 U.S.C. 1001.

A11 DEBARMENT AND SUSPENSION

A11.1 CONTRACT CLAUSE

A11.1.1 Bidder or Offeror Certification

CERTIFICATION OF OFFERER/BIDDER REGARDING DEBARMENT

By submitting a bid/proposal under this solicitation, the bidder or offeror certifies that neither it nor its principals are presently debarred or suspended by any Federal department or agency from participation in this transaction.

A11.1.2 Lower Tier Contract Certification

CERTIFICATION OF LOWER TIER CONTRACTORS REGARDING DEBARMENT

The successful bidder, by administering each lower tier subcontract that exceeds \$25,000 as a "covered transaction", must verify each lower tier participant of a "covered transaction" under the project is not presently debarred or otherwise disqualified from participation in this federally assisted project. The successful bidder will accomplish this by:

1. Checking the System for Award Management at website: <http://www.sam.gov>
2. Collecting a certification statement similar to the Certificate Regarding Debarment and Suspension (Bidder or Offeror), above.
3. Inserting a clause or condition in the covered transaction with the lower tier contract

If the FAA later determines that a lower tier participant failed to disclose to a higher tier participant that it was excluded or disqualified at the time it entered the covered transaction, the FAA may pursue any available remedies, including suspension and debarment of the non-compliant participant.

A12 DISADVANTAGED BUSINESS ENTERPRISE

A12.1 REQUIRED PROVISIONS

A12.1.1 Solicitation Language (Solicitations that include a Project Goal)

The Owner's award of this contract is conditioned upon Bidder or Offeror satisfying the good faith effort requirements of 49 CFR §26.53.

As a condition of bid responsiveness, the Bidder or Offeror must submit the following information with their proposal on the forms provided herein:

- (1) The names and addresses of Disadvantaged Business Enterprise (DBE) firms that will participate in the contract;
- (2) A description of the work that each DBE firm will perform;
- (3) The dollar amount of the participation of each DBE firm listed under (1)
- (4) Written statement from Bidder or Offeror that attests their commitment to use the DBE firm(s) listed under (1) to meet the Owner's project goal;
- (5) If Bidder or Offeror cannot meet the advertised project DBE goal; evidence of good faith efforts undertaken by the Bidder or Offeror as described in appendix A to 49 CFR Part 26.

A12.1.2 Solicitation Language (Race/Gender Neutral Means)

The requirements of 49 CFR part 26 apply to this contract. It is the policy of the City of Aurora to practice nondiscrimination based on race, color, sex or national origin in the award or performance of this contract. The Owner encourages participation by all firms qualifying under this solicitation regardless of business size or ownership.

A12.1.3 Prime Contracts (Projects covered by DBE Program)

DISADVANTAGED BUSINESS ENTERPRISES

Contract Assurance (§ 26.13) - The Contractor or subcontractor shall not discriminate on the basis of race, color, national origin, or sex in the performance of this contract. The Contractor shall carry out applicable requirements of 49 CFR part 26 in the award and administration of Department of Transportation-assisted contracts. Failure by the Contractor to carry out these requirements is a material breach of this contract, which may result in the termination of this contract or such other remedy as the Owner deems appropriate, which may include, but is not limited to:

- 1) Withholding monthly progress payments;
- 2) Assessing sanctions;
- 3) Liquidated damages; and/or
- 4) Disqualifying the Contractor from future bidding as non-responsible.

A13 DISTRACTED DRIVING

A13.1 CONTRACT CLAUSE

TEXTING WHEN DRIVING

In accordance with Executive Order 13513, "Federal Leadership on Reducing Text Messaging While Driving" (10/1/2009) and DOT Order 3902.10 "Text Messaging While Driving" (12/30/2009), the FAA encourages recipients of Federal grant funds to adopt and enforce safety policies that decrease crashes by distracted drivers, including policies to ban text messaging while driving when performing work related to a grant or sub-grant.

In support of this initiative, the Owner encourages the Contractor to promote policies and initiatives for its employees and other work personnel that decrease crashes by distracted drivers, including policies that ban text messaging while driving motor vehicles while performing work activities associated with the project. The Contractor must include the substance of this clause in all sub-tier contracts exceeding \$3,500 and involve driving a motor vehicle in performance of work activities associated with the project.

A14 ENERGY CONSERVATION REQUIREMENTS

A14.1 CONTRACT CLAUSE

ENERGY CONSERVATION REQUIREMENTS

Contractor and Subcontractor agree to comply with mandatory standards and policies relating to energy efficiency as contained in the state energy conservation plan issued in compliance with the Energy Policy and Conservation Act (42 U.S.C. 6201 *et seq.*).

A15 EQUAL EMPLOYMENT OPPORTUNITY (E.E.O.)

A15.1 MANDATORY CONTRACT CLAUSE

A15.1.1 E.E.O. Contract Clause

EQUAL OPPORTUNITY CLAUSE

During the performance of this contract, the contractor agrees as follows:

- (1) The contractor will not discriminate against any employee or applicant for employment because of race, color, religion, sex, or national origin. The contractor will take affirmative action to ensure that applicants are employed, and that employees are treated during employment without regard to their race, color, religion, sex, sexual orientation, gender identify or national origin. Such action shall include, but not be limited to the following: employment, upgrading, demotion, or transfer; recruitment or recruitment advertising; layoff or termination; rates of pay or other forms of compensation; and selection for training, including apprenticeship. The contractor agrees to post in conspicuous places, available to employees and applicants for employment, notices to be provided setting forth the provisions of this nondiscrimination clause.

(2) The contractor will, in all solicitations or advertisements for employees placed by or on behalf of the contractor, state that all qualified applicants will receive considerations for employment without regard to race, color, religion, sex, or national origin.

(3) The contractor will send to each labor union or representative of workers with which he has a collective bargaining agreement or other contract or understanding, a notice to be provided advising the said labor union or workers' representatives of the contractor's commitments under this section, and shall post copies of the notice in conspicuous places available to employees and applicants for employment.

(4) The contractor will comply with all provisions of Executive Order 11246 of September 24, 1965, and of the rules, regulations, and relevant orders of the Secretary of Labor.

(5) The contractor will furnish all information and reports required by Executive Order 11246 of September 24, 1965, and by rules, regulations, and orders of the Secretary of Labor, or pursuant thereto, and will permit access to his books, records, and accounts by the administering agency and the Secretary of Labor for purposes of investigation to ascertain compliance with such rules, regulations, and orders.

(6) In the event of the contractor's noncompliance with the nondiscrimination clauses of this contract or with any of the said rules, regulations, or orders, this contract may be canceled, terminated, or suspended in whole or in part and the contractor may be declared ineligible for further Government contracts or federally assisted construction contracts in accordance with procedures authorized in Executive Order 11246 of September 24, 1965, and such other sanctions may be imposed and remedies invoked as provided in Executive Order 11246 of September 24, 1965, or by rule, regulation, or order of the Secretary of Labor, or as otherwise provided by law.

(7) The contractor will include the portion of the sentence immediately preceding paragraph (1) and the provisions of paragraphs (1) through (7) in every subcontract or purchase order unless exempted by rules, regulations, or orders of the Secretary of Labor issued pursuant to section 204 of Executive Order 11246 of September 24, 1965, so that such provisions will be binding upon each subcontractor or vendor. The contractor will take such action with respect to any subcontract or purchase order as the administering agency may direct as a means of enforcing such provisions, including sanctions for noncompliance: *Provided, however,* That in the event a contractor becomes involved in, or is threatened with, litigation with a subcontractor or vendor as a result of such direction by the administering agency the contractor may request the United States to enter into such litigation to protect the interests of the United States.

A 15.1.2 EEO Specification

STANDARD FEDERAL EQUAL EMPLOYMENT OPPORTUNITY CONSTRUCTION CONTRACT SPECIFICATIONS

1. As used in these specifications:

- a. "Covered area" means the geographical area described in the solicitation from which this contract resulted;
- b. "Director" means Director, Office of Federal Contract Compliance Programs (OFCCP), U.S. Department of Labor, or any person to whom the Director delegates authority;
- c. "Employer identification number" means the Federal social security number used on the Employer's Quarterly Federal Tax Return, U.S. Treasury Department Form 941;
- d. "Minority" includes:
 - (1) Black (all) persons having origins in any of the Black African racial groups not of Hispanic origin);
 - (2) Hispanic (all persons of Mexican, Puerto Rican, Cuban, Central or South American, or other Spanish culture or origin regardless of race);
 - (3) Asian and Pacific Islander (all persons having origins in any of the original peoples of the Far East, Southeast Asia, the Indian Subcontinent, or the Pacific Islands); and
 - (4) American Indian or Alaskan native (all persons having origins in any of the original peoples of North America and maintaining identifiable tribal affiliations through membership and participation or community identification).

2. Whenever the contractor, or any subcontractor at any tier, subcontracts a portion of the work involving any construction trade, it shall physically include in each subcontract in excess of \$10,000 the provisions of these specifications and the Notice which contains the applicable goals for minority and female participation and which is set forth in the solicitations from which this contract resulted.

3. If the contractor is participating (pursuant to 41 CFR 60-4.5) in a Hometown Plan approved by the U.S. Department of Labor in the covered area either individually or through an association, its affirmative action obligations on all work in the Plan area (including goals and timetables) shall be in accordance with that Plan for those trades which have unions participating in the Plan. Contractors shall be able to demonstrate their participation in and compliance with the provisions of any such Hometown Plan. Each contractor or subcontractor participating in an approved plan is individually required to comply with its obligations under the EEO clause and to make a good faith effort to achieve each goal under the Plan in each trade in which it has employees. The overall good faith performance by other contractors or subcontractors toward a goal in an approved Plan does not excuse any covered contractor's or subcontractor's failure to take good faith efforts to achieve the Plan goals and timetables.

4. The contractor shall implement the specific affirmative action standards provided in paragraphs 7a through 7p of these specifications. The goals set forth in the solicitation from which this contract resulted are expressed as percentages of the total hours of employment and training of minority and female utilization the contractor should reasonably be able to achieve in each construction trade in which it has employees in the covered area. Covered construction contractors performing construction work in a geographical area where they do not have a Federal or federally assisted construction contract shall apply the minority and female goals established for the geographical area where the work is being performed. Goals are published periodically in the Federal Register in notice form, and such notices may be obtained from any Office of Federal Contract Compliance

Programs office or from Federal procurement contracting officers. The contractor is expected to make substantially uniform progress in meeting its goals in each craft during the period specified.

5. Neither the provisions of any collective bargaining agreement nor the failure by a union with whom the contractor has a collective bargaining agreement to refer either minorities or women shall excuse the contractor's obligations under these specifications, Executive Order 11246 or the regulations promulgated pursuant thereto.

6. In order for the non-working training hours of apprentices and trainees to be counted in meeting the goals, such apprentices and trainees shall be employed by the contractor during the training period and the contractor shall have made a commitment to employ the apprentices and trainees at the completion of their training, subject to the availability of employment opportunities. Trainees shall be trained pursuant to training programs approved by the U.S. Department of Labor.

7. The contractor shall take specific affirmative actions to ensure equal employment opportunity. The evaluation of the contractor's compliance with these specifications shall be based upon its effort to achieve maximum results from its actions. The contractor shall document these efforts fully and shall implement affirmative action steps at least as extensive as the following:

- a. Ensure and maintain a working environment free of harassment, intimidation, and coercion at all sites, and in all facilities at which the contractor's employees are assigned to work. The contractor, where possible, will assign two or more women to each construction project. The contractor shall specifically ensure that all foremen, superintendents, and other onsite supervisory personnel are aware of and carry out the contractor's obligation to maintain such a working environment, with specific attention to minority or female individuals working at such sites or in such facilities.
- b. Establish and maintain a current list of minority and female recruitment sources, provide written notification to minority and female recruitment sources and to community organizations when the contractor or its unions have employment opportunities available, and maintain a record of the organizations' responses.
- c. Maintain a current file of the names, addresses, and telephone numbers of each minority and female off-the-street applicant and minority or female referral from a union, a recruitment source, or community organization and of what action was taken with respect to each such individual. If such individual was sent to the union hiring hall for referral and was not referred back to the contractor by the union or, if referred, not employed by the contractor, this shall be documented in the file with the reason therefore along with whatever additional actions the contractor may have taken.
- d. Provide immediate written notification to the Director when the union or unions with which the contractor has a collective bargaining agreement has not referred to the contractor a minority person or female sent by the contractor, or when the contractor has other information that the union referral process has impeded the contractor's efforts to meet its obligations.
- e. Develop on-the-job training opportunities and/or participate in training programs for the area which expressly include minorities and women, including upgrading programs and apprenticeship and trainee programs relevant to the contractor's employment needs, especially those programs funded or approved by the Department of Labor. The contractor shall provide notice of these programs to the sources compiled under 7b above.
- f. Disseminate the contractor's EEO policy by providing notice of the policy to unions and training programs and requesting their cooperation in assisting the contractor in meeting its EEO obligations; by including it in any policy manual and collective bargaining agreement; by publicizing it in the company newspaper, annual report, etc.; by specific review of the policy with all management personnel and with all minority and female employees at least once a year; and by posting the company EEO policy on bulletin boards accessible to all employees at each location where construction work is performed.
- g. Review, at least annually, the company's EEO policy and affirmative action obligations under these specifications with all employees having any responsibility for hiring, assignment, layoff, termination, or other employment decisions including specific review of these items with onsite supervisory personnel such as superintendents, general foremen, etc., prior to the initiation of construction work at any job site. A written record shall be made and maintained identifying the time and place of these meetings, persons attending, subject matter discussed, and disposition of the subject matter.
- h. Disseminate the contractor's EEO policy externally by including it in any advertising in the news media, specifically including minority and female news media, and providing written notification to and discussing the contractor's EEO policy with other contractors and subcontractors with whom the contractor does or anticipates doing business.
- i. Direct its recruitment efforts, both oral and written, to minority, female, and community organizations, to schools with minority and female students; and to minority and female recruitment and training organizations serving the contractor's recruitment area and employment needs. Not later than one month prior to the date for the acceptance of applications for apprenticeship or other training by any recruitment source, the contractor shall send written notification to organizations, such as the above, describing the openings, screening procedures, and tests to be used in the selection process.
- j. Encourage present minority and female employees to recruit other minority persons and women and, where reasonable, provide after school, summer, and vacation employment to minority and female youth both on the site and in other areas of a contractor's workforce.
- k. Validate all tests and other selection requirements where there is an obligation to do so under 41 CFR Part 60-3.
- l. Conduct, at least annually, an inventory and evaluation at least of all minority and female personnel, for promotional opportunities and encourage these employees to seek or to prepare for, through appropriate training, etc., such opportunities.
- m. Ensure that seniority practices, job classifications, work assignments, and other personnel practices do not have a discriminatory effect by continually monitoring all personnel and employment related activities to ensure that the EEO policy and the contractor's obligations under these specifications are being carried out.

- n. Ensure that all facilities and company activities are non-segregated except that separate or single user toilet and necessary changing facilities shall be provided to assure privacy between the sexes.
- o. Document and maintain a record of all solicitations of offers for subcontracts from minority and female construction contractors and suppliers, including circulation of solicitations to minority and female contractor associations and other business associations.
- p. Conduct a review, at least annually, of all supervisor's adherence to and performance under the contractor's EEO policies and affirmative action obligations.

8. Contractors are encouraged to participate in voluntary associations, which assist in fulfilling one or more of their affirmative action obligations (7a through 7p). The efforts of a contractor association, joint contractor union, contractor community, or other similar groups of which the contractor is a member and participant, may be asserted as fulfilling any one or more of its obligations under 7a through 7p of these specifications provided that the contractor actively participates in the group, makes every effort to assure that the group has a positive impact on the employment of minorities and women in the industry, ensures that the concrete benefits of the program are reflected in the contractor's minority and female workforce participation, makes a good faith effort to meet its individual goals and timetables, and can provide access to documentation which demonstrates the effectiveness of actions taken on behalf of the contractor. The obligation to comply, however, is the contractor's and failure of such a group to fulfill an obligation shall not be a defense for the contractor's noncompliance.

9. A single goal for minorities and a separate single goal for women have been established. The contractor, however, is required to provide equal employment opportunity and to take affirmative action for all minority groups, both male and female, and all women, both minority and non-minority. Consequently, if the particular group is employed in a substantially disparate manner (for example, even though the contractor has achieved its goals for women generally,) the contractor may be in violation of the Executive Order if a specific minority group of women is underutilized.

10. The contractor shall not use the goals and timetables or affirmative action standards to discriminate against any person because of race, color, religion, sex, or national origin.

11. The contractor shall not enter into any subcontract with any person or firm debarred from Government contracts pursuant to Executive Order 11246.

12. The contractor shall carry out such sanctions and penalties for violation of these specifications and of the Equal Opportunity Clause, including suspension, termination, and cancellation of existing subcontracts as may be imposed or ordered pursuant to Executive Order 11246, as amended, and its implementing regulations, by the Office of Federal Contract Compliance Programs. Any contractor who fails to carry out such sanctions and penalties shall be in violation of these specifications and Executive Order 11246, as amended.

13. The contractor, in fulfilling its obligations under these specifications, shall implement specific affirmative action steps, at least as extensive as those standards prescribed in paragraph 7 of these specifications, so as to achieve maximum results from its efforts to ensure equal employment opportunity. If the contractor fails to comply with the requirements of the Executive Order, the implementing regulations, or these specifications, the Director shall proceed in accordance with 41 CFR 60-4.8.

14. The contractor shall designate a responsible official to monitor all employment related activity to ensure that the company EEO policy is being carried out, to submit reports relating to the provisions hereof as may be required by the Government, and to keep records. Records shall at least include for each employee, the name, address, telephone number, construction trade, union affiliation if any, employee identification number when assigned, social security number, race, sex, status (e.g., mechanic, apprentice, trainee, helper, or laborer), dates of changes in status, hours worked per week in the indicated trade, rate of pay, and locations at which the work was performed. Records shall be maintained in an easily understandable and retrievable form; however, to the degree that existing records satisfy this requirement, contractors shall not be required to maintain separate records.

15. Nothing herein provided shall be construed as a limitation upon the application of other laws which establish different standards of compliance or upon the application of requirements for the hiring of local or other area residents (e.g., those under the Public Works Employment Act of 1977 and the Community Development Block Grant Program).

A16 FEDERAL FAIR LABOR STANDARDS ACT (FEDERAL MINIMUM WAGE)

A16.1 CONTRACT CLAUSE

All contracts and subcontracts that result from this solicitation incorporate by reference the provisions of 29 CFR part 201, the Federal Fair Labor Standards Act (FLSA), with the same force and effect as if given in full text. The FLSA sets minimum wage, overtime pay, recordkeeping, and child labor standards for full and part time workers.

The contractor has full responsibility to monitor compliance to the referenced statute or regulation. The contractor must address any claims or disputes that arise from this requirement directly with the U.S. Department of Labor – Wage and Hour Division.

A17 LOBBYING AND INFLUENCING FEDERAL EMPLOYEES

A17.1 CONTRACT CLAUSE

This provision is required for all contracts that exceed \$100,000.

CERTIFICATION REGARDING LOBBYING

The bidder or offeror certifies by signing and submitting this bid or proposal, to the best of his or her knowledge and belief, that:

- (1) No Federal appropriated funds have been paid or will be paid, by or on behalf of the Bidder or Offeror, to any person for influencing or attempting to influence an officer or employee of an agency, a Member of Congress, an officer or employee of Congress, or an employee of a Member of Congress in connection with the awarding of any Federal contract, the making of any Federal grant, the making of any Federal loan, the entering into of any cooperative agreement, and the extension, continuation, renewal, amendment, or modification of any Federal contract, grant, loan, or cooperative agreement.
- (2) If any funds other than Federal appropriated funds have been paid or will be paid to any person for influencing or attempting to influence an officer or employee of any agency, a Member of Congress, an officer or employee of Congress, or an employee of a Member of Congress in connection with this Federal contract, grant, loan, or cooperative agreement, the undersigned shall complete and submit Standard Form-LLL, "Disclosure Form to Report Lobbying," in accordance with its instructions.
- (3) The undersigned shall require that the language of this certification be included in the award documents for all sub-awards at all tiers (including subcontracts, sub-grants, and contracts under grants, loans, and cooperative agreements) and that all sub-recipients shall certify and disclose accordingly.

This certification is a material representation of fact upon which reliance was placed when this transaction was made or entered into. Submission of this certification is a prerequisite for making or entering into this transaction imposed by section 1352, title 31, U.S. Code. Any person who fails to file the required certification shall be subject to a civil penalty of not less than \$10,000 and not more than \$100,000 for each such failure.

A18 PROHIBITION of SEGREGATED FACILITIES

A18.1 CONTRACT CLAUSE

PROHIBITION of SEGREGATED FACILITIES

(a) The Contractor agrees that it does not and will not maintain or provide for its employees any segregated facilities at any of its establishments, and that it does not and will not permit its employees to perform their services at any location under its control where segregated facilities are maintained. The Contractor agrees that a breach of this clause is a violation of the Equal Opportunity clause in this contract.

(b) "Segregated facilities," as used in this clause, means any waiting rooms, work areas, rest rooms and wash rooms, restaurants and other eating areas, time clocks, locker rooms and other storage or dressing areas, parking lots, drinking fountains, recreation or entertainment areas, transportation, and housing facilities provided for employees, that are segregated by explicit directive or are in fact segregated on the basis of race, color, religion, sex, or national origin because of written or oral policies or employee custom. The term does not include separate or single-user rest rooms or necessary dressing or sleeping areas provided to assure privacy between the sexes.

(c) The Contractor shall include this clause in every subcontract and purchase order that is subject to the Equal Opportunity clause of this contract.

A19 OCCUPATIONAL SAFETY AND HEALTH ACT OF 1970

A19.1 CONTRACT CLAUSE

All contracts and subcontracts that result from this solicitation incorporate by reference the requirements of 29 CFR Part 1910 with the same force and effect as if given in full text. Contractor must provide a work environment that is free from recognized hazards that may cause death or serious physical harm to the employee. The Contractor retains full responsibility to monitor its compliance and their subcontractor's compliance with the applicable requirements of the Occupational Safety and Health Act of 1970 (29 CFR Part 1910). Contractor must address any claims or disputes that pertain to a referenced requirement directly with the U.S. Department of Labor – Occupational Safety and Health Administration.

A20 PROCUREMENT OF RECOVERED MATERIALS

A20.1 CONTRACT CLAUSE

Procurement of Recovered Materials

Contractor and subcontractor agree to comply with Section 6002 of the Solid Waste Disposal Act, as amended by the Resource Conservation and Recovery Act, and the regulatory provisions of 40 CFR Part 247. In the performance of this contract and to the extent practicable, the Contractor and subcontractors are to use of products containing the highest percentage of recovered materials for items designated by the Environmental Protection Agency (EPA) under 40 CFR Part 247 whenever:

- a) The contract requires procurement of \$10,000 or more of a designated item during the fiscal year; or,

The contractor has procured \$10,000 or more of a designated item using Federal funding during the previous fiscal year.

The list of EPA-designated items is available at www.epa.gov/epawaste/conserve/tools/cpg/products/.

Section 6002(c) establishes exceptions to the preference for recovery of EPA-designated products if the contractor can demonstrate the item is:

- a) Not reasonably available within a timeframe providing for compliance with the contract performance schedule;
- b) Fails to meet reasonable contract performance requirements; or
- c) Is only available at an unreasonable price.

A21 RIGHT TO INVENTIONS

A21.1 CONTRACT CLAUSE

RIGHTS TO INVENTIONS

Contracts or agreements that include the performance of experimental, developmental, or research work must provide for the rights of the Federal Government and the Owner in any resulting invention as established by 37 CFR part 401, Rights to Inventions Made by Non-profit Organizations and Small Business Firms under Government Grants, Contracts, and Cooperative Agreements. This contract incorporates by reference the patent and inventions rights as specified within in the 37 CFR §401.14. Contractor must include this requirement in all sub-tier contracts involving experimental, developmental or research work.

A22 SEISMIC SAFETY

A22.1 CONTRACT CLAUSE

A22.1.1 Construction Contracts

Seismic Safety

The contractor agrees to ensure that all work performed under this contract, including work performed by subcontractors, conforms to a building code standard that provides a level of seismic safety substantially equivalent to standards established by the National Earthquake Hazards Reduction Program (NEHRP). Local building codes that model their code after the current version of the International Building Code (IBC) meet the NEHRP equivalency level for seismic safety.

A23 TAX DELINQUENCY AND FELONY CONVICTIONS

A23.1 CONTRACT CLAUSE

CERTIFICATION OF OFFERER/BIDDER REGARDING TAX DELINQUENCY AND FELONY CONVICTIONS

Certifications

- 1) The applicant represents that it is not a corporation that has any unpaid Federal tax liability that has been assessed, for which all judicial and administrative remedies have been exhausted or have lapsed, and that is not being paid in a timely manner pursuant to an agreement with the authority responsible for collecting the tax liability.
- 2) The applicant represents that it is not a corporation that was convicted of a criminal violation under any Federal law within the preceding 24 months.

Note

If an applicant cannot comply with either of the above representations, the applicant is ineligible to receive an award unless the sponsor has received notification from the agency suspension and debarment official (SDO) that the SDO has considered suspension or debarment and determined that further action is not required to protect the Government's interests. The applicant therefore must provide information to the owner about its tax liability or conviction to the Owner, who will then notify the FAA Airports District Office, which will then notify the agency's SDO to facilitate completion of the required considerations before award decisions are made.

The applicant agrees that, if awarded a contract resulting from this solicitation, it will incorporate this provision for certification in all lower tier subcontracts.

Term Definitions

Felony conviction: Felony conviction means a conviction within the preceding twenty-four (24) months of a felony criminal violation under any Federal law and includes conviction of an offense defined in a section of the U.S. code that specifically classifies the offense as a felony and conviction of an offense that is classified as a felony under 18 U.S.C. § 3559.

Tax Delinquency: A tax delinquency is any unpaid Federal tax liability that has been assessed, for which all judicial and administrative remedies have been exhausted, or have lapsed, and that is not being paid in a timely manner pursuant to an agreement with the authority responsible for collecting the tax liability.

A24 TERMINATION OF CONTRACT

A24.1 CONTRACT CLAUSE

A24.1.1 Termination for Convenience

Termination for Convenience (Construction & Equipment Contracts)

The Owner may terminate this contract in whole or in part at any time by providing written notice to the Contractor. Such action may be without cause and without prejudice to any other right or remedy of Owner. Upon receipt of a written notice of termination, except as explicitly directed by the Owner, the Contractor shall immediately proceed with the following obligations regardless of any delay in determining or adjusting amounts due under this clause:

1. Contractor must immediately discontinue work as specified in the written notice.
2. Terminate all subcontracts to the extent they relate to the work terminated under the notice.
3. Discontinue orders for materials and services except as directed by the written notice.
4. Deliver to the owner all fabricated and partially fabricated parts, completed and partially completed work, supplies, equipment and materials acquired prior to termination of the work and as directed in the written notice.
5. Complete performance of the work not terminated by the notice.
6. Take action as directed by the owner to protect and preserve property and work related to this contract that Owner will take possession.

Owner agrees to pay Contractor for:

- a) completed and acceptable work executed in accordance with the contract documents prior to the effective date of termination;

documented expenses sustained prior to the effective date of termination in performing work and furnishing labor, materials, or equipment as required by the contract documents in connection with uncompleted work;

reasonable and substantiated claims, costs and damages incurred in settlement of terminated contracts with Subcontractors and Suppliers; and reasonable and substantiated expenses to the contractor directly attributable to Owner's termination action

Owner will not pay Contractor for loss of anticipated profits or revenue or other economic loss arising out of or resulting from the Owner's termination action.

The rights and remedies this clause provides are in addition to any other rights and remedies provided by law or under this contract.

A24.1.2 Termination for Default

Termination for Default (Construction)

Section 80-09 of FAA Advisory Circular 150/5370-10 establishes conditions, rights and remedies associated with Owner termination of this contract due default of the Contractor.

A25 TRADE RESTRICTION CERTIFICATION

A25.1 CONTRACT CLAUSE

TRADE RESTRICTION CERTIFICATION

By submission of an offer, the Offeror certifies that with respect to this solicitation and any resultant contract, the Offeror -

- a. is not owned or controlled by one or more citizens of a foreign country included in the list of countries that discriminate against U.S. firms as published by the Office of the United States Trade Representative (U.S.T.R.);
- b. has not knowingly entered into any contract or subcontract for this project with a person that is a citizen or national of a foreign country included on the list of countries that discriminate against U.S. firms as published by the U.S.T.R; and
- c. has not entered into any subcontract for any product to be used on the Federal on the project that is produced in a foreign country included on the list of countries that discriminate against U.S. firms published by the U.S.T.R.

This certification concerns a matter within the jurisdiction of an agency of the United States of America and the making of a false, fictitious, or fraudulent certification may render the maker subject to prosecution under Title 18, United States Code, Section 1001.

The Offeror/Contractor must provide immediate written notice to the Owner if the Offeror/Contractor learns that its certification or that of a subcontractor was erroneous when submitted or has become erroneous by reason of changed circumstances. The Contractor must require subcontractors provide immediate written notice to the Contractor if at any time it learns that its certification was erroneous by reason of changed circumstances.

Unless the restrictions of this clause are waived by the Secretary of Transportation in accordance with 49 CFR 30.17, no contract shall be awarded to an Offeror or subcontractor:

- (1) who is owned or controlled by one or more citizens or nationals of a foreign country included on the list of countries that discriminate against U.S. firms published by the U.S.T.R. or
- (2) whose subcontractors are owned or controlled by one or more citizens or nationals of a foreign country on such U.S.T.R. list or

(3) who incorporates in the public works project any product of a foreign country on such U.S.T.R. list;

Nothing contained in the foregoing shall be construed to require establishment of a system of records in order to render, in good faith, the certification required by this provision. The knowledge and information of a contractor is not required to exceed that which is normally possessed by a prudent person in the ordinary course of business dealings.

The Offeror agrees that, if awarded a contract resulting from this solicitation, it will incorporate this provision for certification without modification in all lower tier subcontracts. The contractor may rely on the certification of a prospective subcontractor that it is not a firm from a foreign country included on the list of countries that discriminate against U.S. firms as published by U.S.T.R., unless the Offeror has knowledge that the certification is erroneous.

This certification is a material representation of fact upon which reliance was placed when making an award. If it is later determined that the Contractor or subcontractor knowingly rendered an erroneous certification, the Federal Aviation Administration may direct through the Owner cancellation of the contract or subcontract for default at no cost to the Owner or the FAA.

A26 VETERAN'S PREFERENCE

A26.1 CONTRACT CLAUSE

VETERAN'S PREFERENCE

In the employment of labor (excluding executive, administrative, and supervisory positions), the contractor and all sub-tier contractors must give preference to covered veterans as defined within Title 49 United States Code Section 47112. Covered veterans include Vietnam-era veterans, Persian Gulf veterans, Afghanistan-Iraq war veterans, disabled veterans, and small business concerns (as defined by 15 U.S.C. 632) owned and controlled by disabled veterans. This preference only applies when there are covered veterans readily available and qualified to perform the work to which the employment relates.

SECTION III

Special Provisions

For

AIRFIELD PAVEMENT REHABILITATION, PHASE 3 (AREA 1)

**ILLINOIS PROJECT: ARR-4352
S.B.G. PROJECT: 3-17-SBGP-156**

at

AURORA MUNICIPAL AIRPORT
AURORA, ILLINOIS

January 10, 2020

Prepared By:

CRAWFORD, MURPHY & TILLY, INC.
CONSULTING ENGINEERS
550 N. COMMONS DRIVE, SUITE 116
AURORA, ILLINOIS 60504
<http://www.cmtengr.com>



19028502.00



DATE SIGNED: 01-10-2020
LICENSE EXPIRATION DATE: 11-30-2021

GENERAL

These Special Provisions, together with applicable Standard Specifications, Rules and Regulations, Contract Requirements for Airport Improvement Projects, Payroll Requirements and Minimum Wage Rates which are hereto attached or which by reference are herein incorporated, cover the requirements of the State of Illinois, Department of Transportation, Division of Aeronautics for the construction of the subject project at the Aurora Municipal Airport, Aurora, Illinois.

GOVERNING SPECIFICATIONS AND RULES AND REGULATIONS

The "Illinois Standard Specifications for Construction of Airports", dated April 1, 2012, State of Illinois Department of Transportation, Division of Aeronautics shall govern the project except as otherwise noted in these Special Provisions. In cases of conflict with any part or parts of said specifications, the said Special Provisions shall take precedence and shall govern. When noted within the Special Provisions, the Illinois Department of Transportation "Standard Specifications for Road and Bridge Construction", Adopted April 1, 2016, shall also apply.

INDEX TO SPECIAL PROVISIONS

ITEM – DESCRIPTION	PAGE NUMBER
DIVISION I – GENERAL PROVISIONS	3
SECTION 40 – Scope of Work	3
SECTION 50 – Control Of Work	5
SECTION 60 – Control Of Materials	7
SECTION 70 – Legal Relations And Responsibility To Public	8
SECTION 80 – Prosecution And Progress	10
SECTION 90 – Measurement And Payment	11
DIVISION II – PAVING CONSTRUCTION DETAILS	12
ITEM 150510 – Engineer's Field Office	12
ITEM 152000 – Excavation And Embankment	13
ITEM 208000 – Aggregate Base Course	16
ITEM 209000 – Crushed Aggregate Base Course	19
ITEM 501000 – Portland Cement Concrete Pavement	20
ITEM 501900 – Remove PCC Pavement	26
ITEM 510500 – Tie-Down/Ground Rod	28
ITEM 605000 – Joint Sealing Filler	29
ITEM 620000 – Pavement Marking	32
DIVISION III – FENCING	33
ITEM 162 – Chain-Link Fences	33
DIVISION IV – DRAINAGE	35
ITEM 751000 – Manholes, Catch Basins, Inlets & Inspection Holes.....	35
IDOT DIVISION OF AERONAUTICS POLICY MEMORANDA	A

POLICY MEMORANDA – APPENDIX A INDEX

- 07-21 ACCEPTANCE PROCEDURE FOR FINELY DIVIDED MINERALS USED IN PORTLAND CEMENT CONCRETE AND OTHER APPLICATIONS
- 87-3 MIX DESIGN, TEST BATCH, QUALITY CONTROL, AND ACCEPTANCE TESTING OF PCC PAVEMENT MIXTURES
- 90-1 RESAMPLING AND RETESTING OF PCC PAVEMENT
- 95-1 FIELD TEST PROCEDURES FOR MIXER PERFORMANCE AND CONCRETE UNIFORMITY TESTS
- 97-2 PAVEMENT MARKING PAINT ACCEPTANCE
- 2001-1 REQUIREMENTS FOR COLD WEATHER CONCRETING

DIVISION I – GENERAL PROVISIONS

SECTION 40 – SCOPE OF WORK

40-05 MAINTENANCE OF TRAFFIC

ADD:

The Contractor shall be responsible for cleaning and maintaining all haul roads and use a pick-up type sweeper on all pavements and adjacent roadways utilized in hauling operations when material is tracked onto said pavement. **The Contractor shall have a sweeper on site and maintain all pavements clear of dirt and debris at all times or as requested by the Airport Manager, the Airport Manager's authorized representative or Resident Engineer.** If the Contractor fails to comply with the Standard Specifications, Contract Plans or these Special Provisions concerning traffic control, the Engineer shall execute such work as may be deemed necessary to correct deficiencies and the cost thereof shall be deducted from compensation due or which may become due the Contractor under the contract. The Contractor shall be responsible for supplying, maintaining and moving all barricades required for construction. The cost thereof shall not be paid for separately, but shall be considered incidental to the contract unit prices.

The Airport Manager, following consultation with the Resident Engineer, will give proper notice to the nearest Flight Service Station and the Airways Facilities Chief of the Federal Aviation Administration prior to the beginning of construction.

The Contractor shall consult with the Resident Engineer in arranging his construction operations. The Airport Manager will at all times have jurisdiction over the safety of air traffic during construction. Wherever the safety of air traffic during construction is concerned, his decisions as to methods, procedures and measures used shall be final, and any and all Contractors performing work must be governed by such decisions.

The Contractor shall not be entitled to any extra compensation due to delays or inconveniences caused by said necessary methods, procedures, and measures to protect air traffic.

The Airport Manager shall retain the authority to change the phasing of the work and/or the sequence of construction.

The Contractor shall not have access to any part of the active airfield (runway, taxiway or apron) for all equipment or personnel without the approval of the Airport Manager or the Airport Manager's authorized representative coordinated through the Resident Engineer.

40-09 AIRPORT OPERATIONS DURING CONSTRUCTION

ADD:

a. Construction Activity and Aircraft Movements

For construction activity to be performed in areas other than active operational areas, the storage and parking of equipment and materials, when not in use or about to be installed, shall not encroach upon active operational areas. In protecting operational areas, the minimum clearances maintained for runways shall be in conformance with Part 77 of the Federal Aviation Regulations.

All construction operations shall conform to the plans and in accordance with AC 150/5370-2 (Latest Edition) Operational Safety on Airports During Construction.

The Contractor shall provide their own radio capable of transmitting and receiving on all Airport frequencies.

b. Limitations On Construction

- (1) Open flame welding or torch cutting operations shall be prohibited, unless adequate fire and safety precautions are provided.
- (2) Open trenches, excavations and stockpiled material near any pavements shall be prominently marked with red flags and lighted by light units during hours of restricted visibility and/or darkness.
- (3) Stockpiled material shall be constrained in a manner to prevent movement resulting from aircraft blast or wind conditions.
- (4) The use of explosives shall be prohibited.
- (5) Burning shall not be allowed.

c. Debris

Waste and loose material capable of causing damage to aircraft landing gears, propellers, or being ingested in jet engines shall not be placed on active aircraft movement areas. Material tracked on these areas shall be removed continuously during the work project. The Contractor shall provide garbage cans in employee parking areas and storage areas for debris.

SECTION 50 – CONTROL OF WORK

50-06 CONSTRUCTION LAYOUT

RESPONSIBILITY OF THE RESIDENT ENGINEER

DELETE:

Paragraphs A and B and replace with the following:

- A. The Resident Engineer will locate and reference three (3) control points within the limits of the project.
- B. A benchmark has been established along the project outside of construction lines.

ADD:

M. It is not the responsibility of the Resident Engineer to check the correctness of the Contractor's stakes or forms, except as provided herein; however, any errors that are apparent shall be immediately called to the Contractor's attention, and he shall be required to make the necessary correction before the stakes are used for construction purposes.

RESPONSIBILITY OF THE CONTRACTOR

ADD:

- H. The Contractor shall immediately notify the Resident Engineer of conflicts or discrepancies with the established control points.
- I. Construction layout shall not be paid for separately, but shall be considered incidental to the pay item for which the layout is required.

50-10 INSPECTION OF WORK

ADD:

The Contractor shall provide portable flood lighting for nighttime construction. Sufficient units shall be provided so that work areas are illuminated to a level of five horizontal foot candles. The lighting levels shall be calculated and measured in accordance with the current standards of the Illumination Engineering Society. Lights shall be positioned so as not to interfere with Airport operations.

50-12 LOAD RESTRICTIONS

ADD:

Access to the construction work area is limited to the haul routes as shown in the plans. The use of existing airfield pavements by the Contractor's construction traffic, including all haul traffic, is limited to the hauling routes shown in the plans. Use of existing airfield pavement other than as shown in the plans is prohibited. Any damage to existing airfield pavement due to construction traffic operating within or beyond the approved work limits, hauling within or outside of the approved haul/access routes and construction traffic operating in prohibited areas shall be repaired by the Contractor at his own expense to the satisfaction of the Owner.

The Contractor shall coordinate construction hauling, construction access and load restrictions with the jurisdictional authority as required. The Contractor shall be responsible for damage to any airfield pavement or public road caused by his construction operations. **Any damage to existing airfield pavements or public roads shall be repaired by the Contractor at his own expense to the satisfaction of the Owner. Contractor shall obtain written permission from the Airport Owner to use any airfield pavements.**

50-16 FINAL INSPECTION

ADD:

All work on the punch list shall be considered part of the contract and shall be considered incidental to the completion of the contract. If the Contractor believes that an item listed on the punch list is beyond the scope of the contract, the Contractor shall notify the Engineer in writing prior to commencing work on the punch list item in question. Any punch list items completed by the Contractor without such written notification shall be considered incidental to the contract and shall not be eligible for payment unless determined otherwise by the Engineer and Owner.

50-18 PLANS AND WORK DRAWINGS

DELETE:

References to “approval” in first paragraph and replace with “review”.

REVISE the fifth paragraph to read:

Shop drawings submitted by the Contractor for materials and/or equipment to be provided as a part of the contract shall be reviewed by the Project Engineer for substantial conformance of said materials and/or equipment, to contract requirements. Shop drawings shall be fully descriptive, complete and of sufficient detail for ready determination of compliance.

REVISE the last paragraph to read:

The following information shall be clearly marked on each shop, working, and layout drawing, catalog cut, pamphlet specifications sheet, etc., submitted.

PROJECT LOCATION:	Aurora Municipal Airport
PROJECT TITLE:	Airfield Pavement Rehabilitation, Phase 3 (Area 1)
PROJECT NUMBERS:	IL Project: ARR-4352 SBG Project: 3-17-SBGP-156
CONTRACT ITEM:	(i.e. AR156520 Inlet Protection)
SUBMITTED BY:	(Contractor/Subcontractor Name)
DATE:	(Date Submitted)

SECTION 60 – CONTROL OF MATERIALS

60-01 SOURCE OF SUPPLY AND QUALITY REQUIREMENTS

ADD: After the last paragraph

The Contractor shall certify all materials contained in the contract. Certification documentation shall be submitted to the Engineer. It shall be the sole responsibility of the Contractor to ensure the delivery of adequate and accurate documentation prior to the delivery of the materials.

If, upon delivery and incorporation of any materials, the Contractor has failed to provide the necessary submittals as required by Sections 50-18, 60-01, 60-03 and 60-11 of the Standard Specifications and Special Provisions, the pay item shall not be included on the Construction Progress Payment report until such submittals have been furnished.

60-03 CERTIFICATION OF COMPLIANCE

ADD:

Additional requirements are specified in Section 60-11 Certification of Materials.

60-11 CERTIFICATION OF MATERIALS

ADD:

The Contractor shall certify all materials incorporated into the contract. Certification documentation shall be submitted to the Resident Engineer. It shall be the **sole** responsibility of the Contractor to ensure the submittal of adequate and accurate documentation in order to satisfy the contract material certification requirements **prior** to the delivery of the materials. Materials without certification or those with certification that demonstrates the materials do not meet the requirements of the plans and specifications shall be considered nonconforming and subject to the provisions of Section 50-02.

As a guide to the certification process and requirements, the Contractor shall use the Illinois Department of Transportation/Division of Aeronautics MANUAL FOR DOCUMENTATION OF AIRPORT MATERIALS dated April 1, 2010 or latest edition including any addendums. Copies of this manual are available by contacting Mr. Mike Wilhelm-Division of Aeronautics at (217) 785-4282 or from their website at <http://www.idot.illinois.gov/home/resources/Manuals/Manuals-and-Guides>.

The cost of providing the required material documentation and certifications shall **not** be paid for separately, but shall be considered incidental to the associated item.

All sheets of all submittals shall contain the following information:

PROJECT LOCATION:	Aurora Municipal Airport
PROJECT TITLE:	Airfield Pavement Rehabilitation, Phase 3 (Area 1)
PROJECT NUMBERS:	Illinois Project: ARR-4352 SBG Project: 3-17-SBGP-156
CONTRACT ITEM:	(i.e., AR901510 Seeding)
SUBMITTED BY:	(Contractor/Subcontractor Name)
DATE:	(Date of Submittal)

SECTION 70 – LEGAL RELATIONS AND RESPONSIBILITY TO PUBLIC

70-17 CONTRACTOR'S RESPONSIBILITY FOR UTILITY SERVICE AND FACILITIES OF OTHERS

ADD:

Special care shall be taken on all operations, and particularly near pavement edges, to avoid damage to edge lights and all underground electrical cable on the airport. The approximate location of existing underground cable is shown on drawings. Any airfield lights or cable that are broken and require replacement because of the Contractor's operations will be replaced by the contractor at his own expense.

Any airfield cable repairs or replacement to any part of the electrical system made necessary by the Contractor's operations will be made by him in the manner specified in Sections 108 and 125 at no cost to the airport. Cost of replacement to be borne by the Contractor shall include any expense incurred in locating as well as repairing or replacing damaged parts of the system by the owning agency.

It shall be the Contractor's responsibility to locate and protect all airport-owned utilities within the construction limits. This includes all electrical cables, storm sewer, drain tile, sanitary sewer and water main.

Special attention is necessary when working near FAA power and control cables. Any FAA utility that is damaged or cut during construction shall be repaired immediately. FAA requires that any damaged cable be replaced in its entirety, from power/control source to the equipment/service. Splices of any kind will not be permitted. Exposures of any FAA cables must be done by hand digging or hydro-excavation. No additional compensation will be made for locating, replacement or repair of FAA facilities or cables but, shall be incidental to the contract.

When FAA cables are required to be located, or the contractor is planning on working on or around FAA cables, conduits or equipment, a 10 working day advanced notice shall be given to the FAA before any such markings are required. Once FAA marks the cables, the contractor will be required to survey the FAA utilities so they can be replaced during construction without remarking by the FAA. This shall be incidental to the contract. The FAA personnel are only available from 9 am to 3 pm, Monday through Friday with advanced notice.

Should any utilities or cables require location, the following people shall be contacted:

AURORA MUNICIPAL AIRPORT		
<u>Utility Service or Facility</u>	<u>Contact (Person)</u>	<u>Contact (Phone)</u>
AT&T – Telephone Cables	J.U.L.I.E. (Joint Utility Locating Information for Excavators)	811 or 1-800-892-0123
ComEd - Electric Cables	J.U.L.I.E. (Joint Utility Locating Information for Excavators)	811 or 1-800-892-0123
NICOR - Gas Lines	J.U.L.I.E. (Joint Utility Locating Information for Excavators)	811 or 1-800-892-0123
Water	J.U.L.I.E. (Joint Utility Locating Information for Excavators)	811 or 1-800-892-0123
FAA Control and Communication Cables	FAA Sector Office	1-630-587-7801

70-26 CONTRACTOR'S RESPONSIBILITY FOR SAFETY DURING CONSTRUCTION

ADD the following after Item D.:

- E. Provide a safety officer/construction inspector trained in airport safety to monitor construction activities.
- F. Restrict movement of construction vehicles to construction areas with flagging and barricading, erecting temporary fencing, or providing escorts, as appropriate or as shown in plans.
- G. Ensure that no construction employees, employees of subcontractors or suppliers, or other persons enter any part of the aircraft operations area from construction site unless authorized.

SECTION 80 – PROSECUTION AND PROGRESS

80-03 NOTICE TO PROCEED

ADD:

The Notice to Proceed will not be given until all materials are certified by the Contractor to be available and on hand and meeting the Buy American requirements per the Contract Documents.

80-05 LIMITATION OF OPERATIONS

ADD:

The Contractor shall not have access to any part of the active airfield (aprons, runways or taxiways) for any equipment or personnel without the prior approval of the Airport Manager.

80-07 TEMPORARY SUSPENSION OF THE WORK

REVISE the second paragraph to read:

In the event that the Contractor is ordered by the Engineer to suspend work for some unforeseen cause not otherwise provided for in the contract and over which the Contractor has no control, the Contractor may be reimbursed for actual money expended on the work during the period of shutdown. No allowance will be made for anticipated profits. The period of shutdown shall be computed from the effective date of the Engineer's order to suspend work to the effective date of the Engineer's order to resume the work. Claims for such compensation shall be filed with the Resident Engineer within the time period stated in the Engineer's order to resume work. The Contractor shall submit with his/her claim information substantiating the amount shown on the claim. The Resident Engineer will forward the Contractor's claim to the Division for their consideration in accordance with local laws or ordinances. No provision of this article shall be construed as entitling the Contractor to compensation for delays due to inclement weather, for suspension made at the request of the Engineer, or for any other delay provided for in the contract, plans, or specifications.

SECTION 90 – MEASUREMENT AND PAYMENT

90-05 PAYMENT FOR EXTRA AND FORCE ACCOUNT WORK

ADD the following to subsection B.7. Statements:

All statements of the cost of force account work shall be furnished to the Engineer not later than 60 days after completion of the force account work. If the statement is not received within the specified time frame, all demands for payment for the extra work are waived and the Division, Airport Owner and Local Sponsor are released from any and all such demands. It is the responsibility of the Contractor to ensure that all statements are received within the specified time regardless of the manner or method of delivery.

DIVISION II – PAVING CONSTRUCTION DETAILS

ITEM 150510 – ENGINEER'S FIELD OFFICE

150-2.1

REVISE:

Paragraph (G) to the following:

- (G) One (1) electric water cooler dispenser capable of dispensing cold and hot water and a supply of water bottles as needed.

Paragraph (I) to the following:

- (H) One (1) All-in-One multifunction printer (including maintenance and operating supplies) capable scanning, copying and printing prints up to a half size (11"X 17") with Wi-Fi and Ethernet capabilities.

(I)

ADD:

- (N) One first-aid cabinet fully equipped.
- (O) One (1) 800 Watt, 0.8 cubic foot microwave oven.
- (P) One (1) Coffee Maker
- (Q) Solid waste disposal consisting of two (2) 28-quart waste baskets and an outside trash container of sufficient size to accommodate a weekly provided pick-up service.
- (R) One (1) internet Wi-Fi hotspot with service for use by the Resident Engineer with a minimum advertised download speed of up to 768 Kbps and a minimum advertised upload speed of up to 384 Kbps. The type of internet access device chosen by the Contractor shall allow a minimum of six (6) simultaneous Wi-Fi enabled devices use of the internet connection.

BASIS OF PAYMENT

150-3.1

DELETE the second sentence of the second paragraph of this section.

Payment will be made under:

ITEM AR150510 ENGINEER'S FIELD OFFICE – PER LUMP SUM.

ITEM 152000 – EXCAVATION AND EMBANKMENT

DESCRIPTION

152-1.1

ADD:

All excess material from all contract work shall be hauled offsite at no additional cost to the contract.

Compaction control tests shall be in accordance with ASTM D 1557 (Modified Proctor) for aircraft weights of 60,000 pounds or more.

152-1.2 CLASSIFICATION

DELETE the second, third and fourth paragraphs.

152-1.3 CLEAN CONSTRUCTION OR DEMOLITION DEBRIS

PROJECT CONDITIONS

- A. Prior to bidding, the bidder shall make a site visit to become familiar with the current conditions. He shall also determine the accessibility and assess safety measures that will be necessary to perform the contract work.
- B. Material Sampling and Analysis:
 - 1. The Contractor shall provide his own sampling and analysis in compliance with applicable laws, prior to offsite disposal of all materials. This costs shall be borne by the Contractor at no additional expense to the Owner.

REGULATORY REQUIREMENTS

- A. The Contractor shall comply with all applicable local, state and federal laws and regulations with regard to material removal, handling and disposal, and shall pay all assessed costs and fees.
- B. The Contractor shall comply with the Illinois Environmental Protection Act, as amended by Public Act 096-1416 that was signed in to law on July 30, 2010, Public Act 097-0137 that was signed in to law on July 14, 2011, and all applicable amendments of the Illinois Environmental Protection Act.

SUBMITTALS

- A. Contractor shall submit a Clean Construction or Demolition Debris (CCDD) & Soil Removal and Disposal Plan to the Engineer. Submit the following as a minimum:
 - 1. A list of all construction or demolition debris anticipated to be generated requiring disposal.
 - 2. The anticipated quantity (both in tons and in cubic yards) of construction or demolition debris to be disposed of and identification of disposal facility including address and contact information.
 - 3. The anticipated quantity (both in tons and in cubic yards) of surplus soil to be disposed of, and identification of disposal facility including address and contact information.

CCDD testing shall be by the Contractor, as a minimum, the Contractor shall submit the following:

1. Proposed Testing Program to establish that the surplus soil is uncontaminated, for compliance with the requirements of the Illinois Environmental Protection Act. Include details of intended testing program, and rate of sampling (number of samples based on total quantity of surplus soil generated).
2. Credentials of the testing Lab that will perform the testing, and credentials of the Illinois Licensed Professional Engineer or Illinois Licensed Professional Geologist that will complete all required certification forms.
3. Results of the Proposed Testing Program.
4. If further CCDD testing is deemed necessary by the Contractor's chosen disposal facility, the Contractor shall complete this testing at no additional cost to the contract.

GENERAL

A. The following work shall be included:

1. Removal, handling and legal offsite disposal of all construction or demolition debris generated from all contract work, considering it to be clean construction or demolition debris (CCDD).
2. Removal, handling and legal offsite disposal of surplus soil generated from all contract work, considering it to be uncontaminated.
3. Debris and surplus soil disposal shall include any onsite drying of the material as required, so that the material will pass the paint-filter test as per Method 9095B in USEPA's publication SW 846, prior to transportation.
4. Any costs and fees for legally-permitted-facilities accepting clean construction or demolition debris (CCDD), and/or uncontaminated surplus soil.
5. Additional sampling and testing of surplus soil to establish that it is uncontaminated, and certification to that effect by an Illinois Licensed Professional Engineer or an Illinois Licensed Professional Geologist using Form LPC-663, both as required by law and as required by the site accepting the material.
6. Any other applicable work, costs and fees as required by local, state and federal laws.

MATERIAL CHARACTERIZATION FOR OFFSITE DISPOSAL

- A. Costs for any and all testing, sampling, laboratory analysis or any other document that is required by the recipient of the material (disposal site) to establish that the material is uncontaminated, shall be borne by the Contractor at no additional expense to the Owner.

CONSTRUCTION METHODS

152-2.2 EXCAVATION

REVISE: The 8th paragraph of this section to read:

In cut areas, not requiring porous granular embankment, the top 8" of subgrade shall be compacted to a density of not less than the percentage of the maximum dry density, at optimum moisture, shown in Table 1 as determined by the compaction control tests cited in Division VII for ASTM-1557 (Modified Proctor) for aircraft weights of 60,000 pounds or more. In cut areas, where abandoned utilities,

including duct bank, gas pipe lines, fuel lines, water mains and sewer pipe are encountered, the utilities shall be removed. The cost of removal shall be considered incidental unless it is specifically called out for removal on the plan sheets.

In cut areas, requiring the use of porous granular embankment, the proposed subgrade shall be compacted to the satisfaction of the Resident Engineer.

152-2.10 TOPSOIL

DELETE: The 5th paragraph of this section and REPLACE with:

Any excess excavation material shall be hauled offsite at no additional cost to the contract.

152-2.15 DUST CONTROL WATERING

ADD:

This work shall consist exclusively of the control of dust resulting from construction operations and is not intended for use in the compaction of earth embankment.

Dust shall be controlled by the uniform application of sprinkled water and shall be applied as directed by the Resident Engineer, in a manner meeting his approval.

Dust control watering shall not be paid for separately, but shall be considered incidental to the contract.

METHOD OF MEASUREMENT

152-3.2

DELETE: This section.

152-3.3

DELETE: This section.

BASIS OF PAYMENT

152-4.3

DELETE: This section.

152-4.4

DELETE: This section.

ADD to **152-4.2**:

Clean Construction or Demolition Debris (CCDD) removal and disposal shall not be paid for separately, but shall be included in the unit bid price for "Unclassified Excavation".

Payment will be made under:

ITEM AR152410 UNCLASSIFIED EXCAVATION – PER CUBIC YARD.

ITEM 208000 – AGGREGATE BASE COURSE

DESCRIPTION

208-1.1

REVISE: This section to read:

This item shall consist of porous granular embankment composed of coarse aggregate as specified. It shall be constructed on a prepared subgrade underlying course in accordance with these specifications and shall conform to the dimensions and typical cross section and to the lines and grades as shown on the Plans.

This work shall also consist of furnishing and placing porous granular embankment as the field conditions warrant at the time of construction. This material is intended to repair soft subgrade as determined by the Resident Engineer based on results of geotechnical testing and/or proof roll. Based on the field conditions encountered, the Resident Engineer may specify which PGE gradation is to be used. No adjustment in unit price will be allowed for an increase or decrease in quantities or gradation types used. **Excavation of the soft subgrade shall be not be paid for under Item 208 but shall be paid for under Item 152 Unclassified Excavation.**

MATERIALS

208-2.1 UNCRUSHED COARSE AGGREGATE

DELETE: This Entire Section.

208-2.3 GRADATION

DELETE: This Entire Section.

ADD:

The material shall be free from vegetable matter, lumps or clay, and other objectionable or foreign substance.

When submitting materials for consideration, the Contractor shall provide written certification that the material meets the specified requirements. A written gradation shall also be furnished.

Gradation for Porous Granular Embankment shall be the following gradation:

Sieve Designation	Percentage by weight passing sieves	
	D	E
	3" maximum	2 ½" maximum
4"		
3 inch	100	
2 ½ inch	90-100	100
2 inch	45-75	86-100
1 ½ inch	0-30	35-75
1 inch	0-6	0-16
½ inch		0-6
#4		
IDOT Gradation	CA-1	CA-3

CONSTRUCTION REQUIREMENTS

208-3.2 PREPARING UNDERLYING COURSE

DELETE: This Entire Section.

208-3.3 METHODS OF PRODUCTION

DELETE: This Entire Section.

208-3.4 PLACING

DELETE: This Entire Section.

ADD:

The porous granular embankment shall be placed in lifts no greater than one (1) foot thick or as directed by the Resident Engineer.

208-3.5 FINISHING AND COMPACTING

DELETE: Fifth sentence, first paragraph.

ADD:

Rolling the top of the aggregate material with a vibratory roller meeting the requirements of Section 1101 of the IDOT *Standard Specification for Road and Bridge Construction* should be sufficient to obtain the desired keying, interlocking and necessary compaction. The Resident Engineer shall verify that adequate keying and interlocking has been obtained. The base shall be compacted to the satisfaction of the Resident Engineer.

Capping aggregate (six (6) inch depth) meeting the requirements of Section 209 of the Standard Specifications will be required to be placed on top of the porous granular embankment.

DELETE: Second paragraph.

DELETE: Second sentence, third paragraph and REPLACE with:

When the rolling develops irregularities that exceed 3/8 inch when tested using an acceptable method, the irregular surface shall be loosened, refilled with the same kind of material as that used in constructing the course, and rolled again as required.

METHOD OF MEASUREMENT

208-4.1

DELETE: This Entire Section and Replace with:

The quantity of Porous Granular Embankment shall be the number of cubic yards as measured by the Engineer at the specified thickness of the material placed. If required, the thickness of PGE measured for payment will include the thickness of the capping stone.

The porous granular embankment shall be used as shown and as field conditions warrant at the time of construction. No adjustment in unit price will be allowed for an increase or decrease in quantities.

The Contractor shall furnish approved duplicate load tickets upon which is recorded the net weight of the aggregates in each truck. The Contractor shall submit one (1) load ticket to the Resident Engineer, or his/her duly authorized representative, at the job site when the truck load is incorporated into the base.

208-4.2

DELETE: This Entire Section.

208-4.3

DELETE: This Entire Section.

BASIS OF PAYMENT

208-5.1

DELETE: Entire Section.

ADD:

Porous granular embankment shall be paid for at the contract unit price per cubic yard, of which price shall be full compensation for the two (2) inch capping stone (if necessary), furnishing, spreading, compacting, watering and all incidentals related to equipment, labor and tools necessary to complete this work.

Payment will be made under:

ITEM AR208515 POROUS GRANULAR EMBANKMENT – PER CUBIC YARD.

ITEM 209000 – CRUSHED AGGREGATE BASE COURSE

DESCRIPTION

209-1.1

ADD:

In areas of new 9" PCC pavement installation, where existing +/- 4" HMA and asphalt treated permeable subbase have been removed, a new open graded crushed aggregate base shall be installed. The contractor shall regrade and compact the existing aggregate base course to the satisfaction of the Resident Engineer.

In areas of new 9" PCC pavement installation, where existing aggregate base is present, the contractor shall regrade and compact the existing aggregate base course to the satisfaction of the Resident Engineer. Any additional aggregate fill or excavation necessary to meet the base grade shall be to the satisfaction of the Resident Engineer and will not be measured payment.

MATERIALS

209-2.1 CRUSHED COARSE AGGREGATE

DELETE: Table 1. Requirements for Gradation of Aggregate.

ADD: Aggregate gradation shall meet an IDOT CA-11.

CONSTRUCTION METHODS

209-3.4 FINISHING AND COMPACTING

ADD:

The base shall be compacted to the satisfaction of the Resident Engineer.

BASIS OF PAYMENT

209-5.1

ADD:

No separate payment will be made for the regrading and recompacting of the existing aggregate base to remain in areas of pavement removal and replacement and is incidental to the respective pavement pay item. This includes all labor, tools, equipment, materials, excavation and incidentals necessary to prepare the existing aggregate base course for paving.

Payment will be made under:

ITEM AR209604 CRUSHED AGG. BASE COURSE – 4" – PER SQUARE YARD.

ITEM AT209604 CRUSHED AGGREGATE BASE COURSE–4" – PER SQUARE YARD.

ITEM 501000 – PORTLAND CEMENT CONCRETE PAVEMENT

DESCRIPTION

501-1.1

ADD:

This work shall also consist of a 9" pavement for Runway 9/27 repairs composed of a high early strength Portland cement concrete.

This work shall also include the repair of spalled edges of the existing concrete surfaces in the areas identified in the plans or as directed by the Resident Engineer.

All turf disturbed for the construction of new PCC pavement shall be restored to the satisfaction of the Airport. Restoration of turf areas shall be incidental to Item 501.

MATERIALS

501-2.4 PREMOLDED JOINT FILLER

REWRITE the first sentence to read:

Premolded joint filler for expansion joints shall be a flexible foam expansion joint composed of isomeric polymers in a very small, closed cell structure and shall meet the requirements of ASTM D-1752, Sections 5.1 through 5.4, with the compression requirement modified to 10 psi (7.03 g/mm²) minimum and 25 psi (17.58 g/mm²) maximum.

501-2.6 STEEL REINFORCEMENT

REWRITE the first sentence to read:

Reinforcing of odd-shaped panels shall consist of Welded Steel Wire Fabric of the size and dimensions shown in the plans and conforming to the requirements of ASTM A-185.

501-2.7 DOWEL AND TIE BARS

ADD:

All dowel bars shall be fastened firmly in position with an approved contraction joint dowel bar assembly prior to the start of paving operations or mechanically inserted per article 420.05 of the IDOT Standard Specifications for Road and Bridge Construction. Loose dowel bars will not be accepted.

Contraction Joint Assembly. The contraction joint assembly shall be an approved welded assembly possessing the rigidity to hold the dowels during the placing and compacting of the concrete to the degree of alignment specified hereinafter. The assembly shall have 4 parallel spacer bars and 2 subgrade-bearing members. An upright support at each end of dowel shall be welded to both the outside spacer bar and the bearing member at appropriate points to hold the dowels at the design height. The two inside spacer bars shall be spaced approximately 2 inches on each side of center.

The dowels shall be spaced as shown on the plans and alternate ends shall be welded to the outside spacer bars. One weld is permitted per bar. The end of each dowel not welded to a spacer bar shall be securely held in place by means of wire loops or metal tubes welded to the other outside spacer bar. Suitable ties shall be provided to hold the assembly in normal position during shipping, handling and installation. Wire sized shall not be less than W7 for the outside spacer bars, bearing members and upright supports and W5 wire for the 2 inside spacer bars. The tie wires used for securing the spacer bars shall not be less than W3 wires.

The assembly shall be provided with 2 continuous bearing plates of not less than 2-inch width and not less than 0.0359 inches thickness sheet steel. The bearing plates shall be attached by welding to the subgrade members or by suitable clips and shall be punched to receive the protruding ends of the upright supports and stakes. The stakes shall be driven parallel to and next to the upright supports. The subgrade bearing members may be omitted if suitable subgrade plates are shop welded to the assembly and provide equivalent rigidity. Bearing plates will not be required on stabilized subbase. The welds in the assembly shall be securely made. A broken weld will be sufficient cause for rejection of the length or section of the assembly in which it occurs.

501-2.9 COVER MATERIAL FOR CURING

DELETE: (b), (c) and (d).

REVISE: (a) as follows:

Curing materials shall be liquid membrane-forming compounds conforming to the requirements of ASTM C-309, Type 2 (White Pigmented).

501-2.9 EPOXY RESIN FOR SPALLS

ADD:

All epoxy-resin mortar shall be a two-component material conforming to the requirements of ASTM C881, Type III. Class as appropriate for each application temperature to be encountered,

CONSTRUCTION METHODS

501-3.1 EQUIPMENT

501-3.1(e) FORMS

ADD:

All radii and tapers shall be formed with flexible forms.

501-3.3 CONDITIONING OF UNDERLYING COURSE, SLIP-FORM CONSTRUCTION

DELETE: The first sentence.

ADD:

The existing grade along the outer edges of the new pavement shall be improved, if necessary, to support the paver without noticeable displacement. Any grading, compacting, or furnishing and installing materials shall be considered incidental to the unit prices for paving and no separate payment will be made.

All areas shall be constructed true to grade and acceptable to the Engineer prior to paving.

During placement of the concrete pavement, the subbase shall be maintained in a moist condition without accumulation of pools of water.

In the event that the underlying course has become over-saturated or unstable, paving operations shall stop until corrected unless otherwise approved by the Engineer.

501-3.4 CONDITIONING OF UNDERLYING COURSE, SIDE-FORM CONSTRUCTION

ADD:

All areas shall be constructed true to grade and acceptable to the Engineer prior to paving.

During placement of the concrete pavement, the subbase shall be maintained in a moist condition without accumulation of pools of water.

In the event that the underlying course has become over-saturated or unstable, paving operations shall stop until corrected unless otherwise approved by the Engineer.

501-3.6(a) PROPORTIONS

DELETE: This section.

501-3.6(b) PROPORTIONS

ADD:

The Portland cement concrete for Runway 9/27 repairs shall be per the requirements of the Illinois Department Transportation "Standard Specifications for Road and Bridge Construction" Section 420 Portland Cement Concrete and Section 1020 Portland Cement Concrete and shall be Class PP-2. The concrete mix shall be generated by the IDOT Division of Highways with recent substantiating test and strength data for approval by the Engineer. The Class PP-2 shall be designed for field flexural strength of 600 psi at 24 hours. Test batch for Class PP-2 concrete is not required.

The Contractor has the option to transport and cure the beams at an IDOT approved laboratory facility as approved by the Engineer.

501-3.7 FIELD TEST SPECIMENS

ADD:

For Runway 9/27 pavement repairs where high early concrete is utilized, the Contractor's quality control personnel shall also take three (3) random flexural strength samples of the day's placement for use in determining when the pavement may be open to traffic.

The Contractor shall provide a system of marking and tracking samples taken in the field. The system shall be provided at the Preconstruction conference and shall, at a minimum, provide location of sample, lot number and curing and reporting of all test specimens manufactured by the Contractor's personnel.

The Contractor shall provide the forms or molds used to make compressive test cylinders and flexural beam specimens.

The Contractor has the option to transport and cure the beams at an IDOT approved laboratory facility as approved by the Engineer.

501-3.12 JOINTS

ADD: To the end of the paragraph (B) Installation:

Protection of previously sawed joints from slip-form operations shall be provided in the form of rubber mats or other means acceptable to the Engineer. The Contractor shall be required to place rubber mats (or other approved material) along the pavement edge prior to drilling dowel bar holes. In addition, any damage to the pavement caused by the drilling operation shall be repaired to the satisfaction of the Engineer at no additional cost to the contract.

501-3.14 SURFACE TEXTURE

ADD:

The surface of the pavement shall be finished with a burlap drag or other approved method acceptable to the Resident Engineer.

501-3.17 CURING

(a) **Impervious Membrane Method** shall be utilized for this project.

ADD:

For slip-form paving, the approved curing media shall be applied uniformly to all surfaces of the pavement, including exposed edges. Membrane curing compounds shall be applied on all concrete surfaces from a suitable self-propelled mechanical application device, which bridges the fresh concrete, designed to provide a uniform application. Other curing systems will not be permitted.

Care shall be taken when this method of curing is used. Should conditions prevail such that curing material is being blown toward buildings or aircraft, appropriate measures shall be taken to eliminate the problems to the satisfaction of the Engineer. Two (2) separate applications, applied at least five minutes apart, each at the rate of not less than 1 gallon per 250 square feet will be required upon surfaces and edges of the concrete. Another application shall be necessary to cover any deficient areas less than 1 gallon per 125 square feet. The curing membrane shall be sprayed as soon as possible without damage to the pavement surface. Excessive delays in application of the membrane resulting in shrinkage cracking will be cause for rejection of the affected pavement necessitating removal and replacement at no additional cost to the contract.

501-3.21 OPENING TO TRAFFIC

ADD:

If the Contractor elects not to wait 14 calendar days, after paving is completed in a work area, to reopen the area to airfield traffic. The Contractor shall be required to make and break additional concrete beam specimens to verify the required flexural strength is obtained. The Contractor shall provide the Resident Engineer with copies of the test results prior to opening the work area to airfield traffic.

501-3.24 TEST SECTION FOR SLIP-FORM PAVERS

Prior to paving using the slip-form paving method, an area of the new pavements designated by the Engineer shall be paved to develop and demonstrate satisfactory procedures and concrete mix. The test section shall be located within the new pavement limits and all costs associated with the test section shall be incidental to this item.

501-3.25 GRADE CONTROL FOR SLIP-FORM PAVERS

Grade control on all free edges of slip-form pavement shall be from string lines. The use of transverse grade control from the paver will not be permitted.

501-3.26 PROTECTION OF PAVEMENT AGAINST RAIN

In order that the concrete may be properly protected against the effects of rain before the concrete is sufficiently hardened, the Contractor will be required to have available at all times materials for the protection of the edges and surface of the unhardened concrete. Such protective materials shall consist of standard metal forms or wood plank having a nominal thickness of the pavement at its edge for the protection of the pavement edges, and covering material such as curing paper or polyethylene sheeting material for the protection of the surface of the pavement. The metal forms, wood planks and curing paper shall be kept on trucks or towable vehicles, within reasonable hauling distance, at a site shown on the plans, or as designated by the Engineer. Or, as an alternate, rolled polyethylene sheeting of sufficient length and width may be used without the temporary side forms and if properly anchored, to cover the plastic concrete slab and exposed edge. The sheeting may be mounted on either the paver or a separate moveable bridge from which it can be unrolled without dragging over the plastic concrete surface. When rain appears imminent, all paving operations shall stop and all available personnel shall begin covering the surface of the unhardened concrete with the protective covering. All pavement damaged shall be removed and replaced at no additional cost to the contract.

501-3.27 REMOVAL OF DEFECTIVE WORK

At locations determined by the Engineer, the contractor shall be required to remove any pavement which is classified as defective. This includes any area where non-controlled (random) cracking occurs, unacceptable surface texturing or any other defect determined unacceptable by the Engineer. The pavement shall be removed to the nearest joint and replaced at the expense of the Contractor. Prior to replacement, dowels and tie bars shall be provided as directed by the Engineer.

501-3.28 REPAIRING SPALLS ALONG JOINTS.

Where directed, spalls along joints of existing slabs, edges of existing slabs, and along parallel cracks used as replacement joints, shall be repaired by first making a vertical saw cut at least 2 inches (25 mm) outside the spalled area and to a depth of at least 2 inches (50 mm). Saw cuts shall be straight lines forming rectangular areas. The concrete between the saw cut and the joint shall be chipped out to remove all unsound concrete and at least 1/2 inch (12 mm) of visually sound concrete. The cavity thus formed shall be thoroughly cleaned with high pressure water jets supplemented with compressed air to remove all loose material. Immediately before filling the cavity, a prime coat of epoxy resin, Type III, Grade I, shall be applied to the dry cleaned surface of all sides and bottom of the cavity, except any joint face. The prime coat shall be applied in a thin coating and scrubbed into the surface with a stiff bristle brush, pooling of epoxy resin shall be avoided. The cavity shall be filled with a Grade III epoxy resin. Epoxy resin mortars shall be made with Type III, Grade I, epoxy resin, using proportions and mixing and placing procedures as recommended by the manufacturer and approved by the Engineer. The epoxy resin materials shall be placed in the cavity in layers not over 2 inches (50 mm) thick. The time interval between placement of additional layers shall be such that the temperature of the epoxy resin material does not exceed 140° F (60° C) at any time during hardening. Any repair material on the surrounding surfaces of the existing concrete shall be removed before it hardens. Where the spalled area abuts a joint, an insert or other bond-breaking medium shall be used to prevent bond at the joint face. A reservoir for the joint sealant shall be sawed to the dimensions required for other joints, or as required to be routed for cracks. The reservoir shall be thoroughly cleaned and sealed with the sealer specified for the joints. If any spall penetrates half the depth of the slab or more, the entire slab shall be removed and replaced as previously specified.

METHOD OF MEASUREMENT

501-4.1

ADD:

The quantity of PCC spall repair shall be the number of square feet of spall repair performed as specified, in place, completed and accepted by the Resident Engineer. Only existing spalls designated by the engineer for repair shall be measured. Any edge spall that has been caused by the contractor's operation and subsequently repaired shall not be measured for payment. Sealing joints along spalls shall not be measured for payment but shall be considered incidental to the spall.

The quantity of PCC pavement necessary to complete drainage inlet and utility block out reconstructions will not be measured separately for payment, but shall be incidental to the respective inlet/utility reconstruct pay item.

All turf areas disturbed shall be restored to the satisfaction of the airport. Restoration of turf areas shall be incidental to the Item 501.

BASIS OF PAYMENT

501-5.1 GENERAL

ADD:

The quantity of PCC spall repair measured as outlined in Section 501-4.1 shall be paid for at the contract unit price for the area that is completed and accepted by the Resident Engineer. These prices shall be full compensation for furnishing all materials and for all preparation, delivering and installation of these materials, and for all labor, equipment, tools and incidentals necessary to complete the item.

Payment will be made under:

- | | |
|----------------------|--|
| ITEM AR501509 | 9" PCC PAVEMENT – PER SQUARE YARD. |
| ITEM AR501530 | PCC TEST BATCH – PER EACH. |
| ITEM AR800009 | PCC SPALL REPAIR – PER SQUARE FOOT. |
| ITEM AS800075 | 9" PCC PAVEMENT – HIGH EARLY MIX – PER SQUARE YARD. |
| ITEM AT501509 | 9" PCC PAVEMENT – PER SQUARE YARD. |

ITEM 501900 – REMOVE PCC PAVEMENT

DESCRIPTION

501-1.1

ADD: To the second sentence.

The types of materials to be removed consist of PCC pavement (approximately 9” to 13”). As noted in the construction plans, areas of the existing west apron have an approximate 4” HMA base course or 4” asphalt treated permeable base. In areas of PCC removal within the existing west apron, PCC removal shall include the existing HMA/asphalt treated permeable base. Pavement structure information was taken from airport records, data supplied by airport personnel and soil borings. The Contractor shall verify the type and thickness of materials to be removed. **No additional compensation will be allowed for any variations in the pavement sections actually encountered.**

CONSTRUCTION METHODS

501-3.1

ADD:

The existing pavement areas to be removed shall be done in such a manner as to prevent damage to the adjacent structures and pavement. All pavement and base material removed shall be disposed of off airport property. All edges adjacent to existing pavements shall be saw cut full depth prior to removal as directed by the Engineer.

METHOD OF MEASUREMENT

501-4.1

ADD:

The area of pavement removal shall be measured by the number of square yards of pavement removed, and properly disposed, as shown on the plans or as directed by the Resident Engineer.

HMA/asphalt treated permeable bases removed under PCC pavement shall not be measured separately for payment but shall be incidental to the respective Remove PCC Pavement pay item.

If additional pavement or subgrade material is removed due to negligence of the Contractor, the additional quantity of pavement removal and replacement will not be measured for payment.

BASIS OF PAYMENT

501-5.1

ADD:

Payment shall constitute full compensation for pavement removal, saw cutting and disposal of the removed materials, including all labor, tools, equipment and incidentals necessary to complete this item of work. Any work grading and recompacting of existing granular base course to proper grade shall not be paid for separately but shall be considered incidental to pavement removal.

Payment will be made under:

- ITEM AR501900 REMOVE PCC PAVEMENT – PER SQUARE YARD.**
- ITEM AS501900 REMOVE PCC PAVEMENT – PER SQUARE YARD.**
- ITEM AT501900 REMOVE PCC PAVEMENT – PER SQUARE YARD.**

ITEM 510500 – TIE-DOWN/GROUND ROD

MATERIALS

510-2.1

ADD:

Ground rods shall be ¾" diameter x 10' copperweld.

CONSTRUCTION METHODS

510-3.1

ADD:

Ground rods shall be installed after paving is completed. A 4" diameter hole shall be cored through the pavement. The ground rod shall be driven to ¼" below finished pavement surface. Coring and grouting shall be considered incidental to the ground rod installation.

BASIS OF PAYMENT

510-5.1

ADD:

Payment will be made under:

ITEM AR510510	TIE DOWN – PER EACH.
ITEM AR510515	GROUND ROD – PER EACH.

ITEM 605000 – JOINT SEALING FILLER

DESCRIPTION

605-1.1

ADD:

Joint sealing filler shall be provided to seal joints in the new concrete pavement to prevent infiltration of incompressible material into the new joints and to seal joints between the new concrete pavement and existing concrete pavement as specified herein and as shown on the plans. The cost of furnishing and installing joint sealing filler in new pavement and between new and existing pavement shall be considered incidental to Item 501.

Joint sealing filler shall also be provided to seal joints in the existing concrete pavement to prevent infiltration of incompressible material into the existing concrete joints in the areas outlined in the plans. The existing joints vary in depth and width and contain hot pour or preformed joint sealant material which is to be removed and replaced with new joint sealant as specified herein and as shown on the plans. The existing joints shall be widened as noted on the plans.

This section shall apply to all concrete/concrete, and concrete/bituminous interface joint sealing. The Contractor shall be limited to silicone joint sealant only.

MATERIALS

605-2.1 NON-SILICONE JOINT SEALING MATERIALS

DELETE: The entire section.

605-2.2 SILICONE JOINT SEALING MATERIALS

REVISE: This section to the following:

The silicone joint sealing material shall be single-component, low-modulus, neutral-curing, nonsag silicone sealant complying with ASTM D5893 for Type NS. Self-leveling silicone joint sealant complying with ASTM D5893 for Type SL shall be allowed for sealing concrete/bituminous or bituminous/bituminous interfaces only. Type NS sealant shall not be used when at least one side of the joint is a bituminous pavement.

CONSTRUCTION

605-3.2 EQUIPMENT

A. For non-silicone joint sealers:

DELETE: The entire section.

605-3.3 PREPARATION OF JOINTS

REVISE: Entire section to the following:

New PCC Pavement

The joint shall be sawed to the dimensions shown on the plans. Immediately after performing the saw cut, both faces of the joint shall be cleaned of all laitance and contaminants using a high pressure water wash with a minimum pressure of 3,000 psi (20,500 kPa) to the satisfaction of the Resident Engineer. The joint shall be allowed to dry overnight.

Prior to sealing, the joint shall be cleaned of debris using clean compressed air at a minimum pressure of 90 psi (620 kPa). Gas or electric powered blowers are not acceptable.

The Contractor shall not install any joint sealer material until the Resident Engineer has inspected and approved the condition of the joints immediately prior to the installation of the sealer.

Existing PCC Pavement

All existing joints to be sealed shall be widened, sandblasted or waterblasted. Immediately ahead of the sealer placement, all laitance, sand, dust and debris shall be blown from the joint or crack with oil free compressed air at a minimum pressure of 90 psi and the pneumatic tool lubricator must be bypassed and a filter installed on the discharge valve to keep water and oil out of the lines.

No sealant shall be installed until all cracks and joints have been cleaned free of all deleterious materials, including any dust, existing sealant, incompressibles, debris and organic material. Sealant shall be placed in a clean, dry crack or joint.

When vegetation exists in the existing cracks and joints, it shall be removed and those cracks and joints shall be treated with a herbicide that sterilizes the soil subject to the approval of the Engineer.

605-3.4 PLACING JOINT SEALER

A. For non-silicone joint sealers:

DELETE: The entire section.

METHOD OF MEASUREMENT

605-4.1

DELETE: The entire section.

ADD:

No measurement will be made for direct payment of filler, as the cost of furnishing and installing shall be considered as a subsidiary obligation in the completion of the construction of the new concrete pavements. Therefore, joint sealant shall not be measured separately for payment but shall be incidental to Item 501.

The joint sawing and sealing for the new PCC pavement and between existing and new PCC pavement shall be incidental to Item 501. No separate measurement for payment will be made for this item.

Sealing of existing joints shall be measured for payment by the linear foot as measured and accepted by the Engineer in conformance with the plans and specifications.

BASIS OF PAYMENT

605-5.1

DELETE: The entire section.

ADD:

Payment for joint sealing in the new PCC Pavement and between new and existing PCC pavement shall be incidental to Item 501.

Payment for joint sealing in existing pavement shall be based on the contract unit price for the length of sealant measured and accepted by the Engineer. Sealing of existing isolation joints shall be paid for under Clean & Seal Expansion Joints. The cost of widening, cleaning and sealing existing joints of different widths, depths, back rod sizes, saw cutting depths and quantity of sealant material shall be included in the contract unit price for Clean and Seal Expansion Joints and shall not be considered for any additional compensation due to the existing joints varying in widths and depths.

These prices shall be full compensation for furnishing all materials and for all preparation, delivering and installation of these materials, and for all labor, equipment, tools and incidentals necessary to complete the item.

Payment will be made under:

ITEM AR605542 CLEAN & SEAL EXPANSION JOINTS – PER LINEAR FOOT.

ITEM 620000 – PAVEMENT MARKING

MATERIALS

620-2.2 PAINT

ADD:

All paint shall be waterborne. Red paint shall conform to Federal Specification TT-P-1952D, Type 1.

The paint shall contain no lead, chromium, cadmium or barium.

CONSTRUCTION METHODS

620-3.3 PREPARATION OF SURFACE

ADD:

Existing marking that is to be re-painted shall be cleaned using sand blasting or high pressure water or other methods as approved by the Engineer to remove dirt, grease, laitance, loose or flaking paint and any paint that is not bonding, at no additional cost to the contract.

620-3.9 CLEAN UP

ADD:

The Contractor shall remove from the work area all debris, waste, loose or un-adhered reflective media, and by-products generated by the surface preparation and application operations to the satisfaction of the Resident Engineer. The Contractor shall dispose of these wastes in strict compliance with all applicable state, local and federal environmental statutes and regulations.

METHOD OF MEASUREMENT

620-4.1

ADD:

The quantity of permanent markings to be paid for shall be the number of square feet of painting with the specified material **measured only once to apply two coats** in conformance with the specifications and accepted by the Engineer. Quantities will not be distinguished between different colors of paint, except that black paint shall not require reflective media. Only the top coat of paint shall require reflective media.

BASIS OF PAYMENT

ADD:

Payment will be made under:

ITEM AS620520 PAVEMENT MARKING-WATERBORNE – PER SQUARE FOOT.

DIVISION III – FENCING

ITEM 162 – CHAIN-LINK FENCES

DESCRIPTION

162-1.1

ADD:

The existing 6-foot fence to be removed is mounted on the existing PCC pavement with floor flanges.

The new 6-foot fence shall also be surface mounted with floor flanges to the new PCC pavement. Salvageable portions of the existing 6-foot removed may be incorporated into the new installation. Top rail will be required.

CONSTRUCTION METHODS

162-3.2 INSTALLING POSTS

ADD:

Posts installed in pavement, shall have the pavement removed as noted on the plans. The pavement to be removed shall be saw cut or cored its full depth. Saw cuts shall be straight lines forming square areas. Over sawing of the pavement will not be allowed.

162-3.5 INSTALLING FABRIC

REVISE: Subsection C, second sentence, to read: The fastenings shall **not** be spaced more than 14 inches on centers for line posts.

162-3.9 EXISTING FENCE CONNECTIONS

ADD:

Connections between new and existing fence shall be considered incidental to the contract.

162-3.11 FENCE AND GATE REMOVAL

ADD:

Portions of the fence materials that are not salvageable shall be disposed of by the Contractor off of Airport property at no additional cost to the project. All other salvageable materials shall be reincorporated into the new fence.

Removal of the existing chain link fence includes removal of all fence posts. No distinction of post diameter will be made for payment purposes. The Contractor shall examine the site prior to submitting a proposal.

162-3.15 CONTRACTOR'S RESPONSIBILITY FOR UTILITY LOCATING

The approximate location of known underground utilities is presented on the plans.

It shall be the Contractor's responsibility to determine the actual location of all utilities, including service connections to underground utilities. Prior to construction, the Contractor shall contact JULIE, FAA and Airport Maintenance. Prior to construction, the Contractor shall notify all utility companies of his operational plans. The Contractor shall make arrangements for detailed information and assistance in locating utilities. In the event an unexpected utility interference is encountered during construction, the Contractor shall immediately notify the utility company, the Owner and the Resident Engineer. Any such mains and/or services disturbed by the Contractor's operations shall be restored immediately at his expense to the satisfaction of the Owner and the Engineer.

The Contractor shall be responsible for keeping the owner advised of this plan of operations. Prior to commencing work in the general vicinity of an existing utility service or facility, the Contractor shall notify the owner of his plan of operation.

METHOD OF MEASUREMENT

BASIS OF PAYMENT

162-5.1

ADD:

Connections between the existing fence to remain and the new fence shall be considered incidental to the new fencing items and shall not be included for payment.

Payment will be made under:

**ITEM AT162506 CLASS E FENCE 6' – PER LINEAR FOOT.
ITEM AT162900 REMOVE CLASS E FENCE – PER LINEAR FOOT.**

DIVISION IV – DRAINAGE

ITEM 751000 – MANHOLES, CATCH BASINS, INLETS & INSPECTION HOLES

DESCRIPTION

751-1.1

ADD:

Specifically, this item consists of the reconstruction of existing inlets and utility structures as shown on the plans or as directed by the Engineer.

MATERIALS

751-2.3 CONCRETE

ADD:

Plain and reinforced concrete used in inlet reconstructs and pavement box outs shall conform to the requirements of Item 501.

CONSTRUCTION METHODS

751-3.12 INLET/MANHOLE RECONSTRUCTION

Reconstruction of existing inlets/utility structures shall be accomplished by removing the existing cast in place top and frame and grate and constructing a new cast-in-place top with new frame and grate/lid as detailed on the plans. The reconstruction shall also include patching the existing walls and flowline to the satisfaction of the Resident Engineer. The contractor shall be responsible for field checking existing inlets and storm sewer configurations for the necessary reconstructions.

BASIS OF PAYMENT

751-5.1

ADD:

Payment will be made under:

ITEM AR751980 RECONSTRUCT INLET – PER EACH.

ITEM AT751995 RECONSTRUCT UTILITY STRUCTURE- PER EACH.

IDOT DIVISION OF AERONAUTICS POLICY MEMORANDA

**State of Illinois
Department of Transportation
Bureau of Materials and Physical Research**

POLICY MEMORANDUM

January 1, 2007

Springfield

07-21

TO: REGIONAL ENGINEERS, HIGHWAY BUREAU CHIEFS, AND
MANUFACTURERS AND SUPPLIERS OF FINELY DIVIDED MINERALS

SUBJECT: ACCEPTANCE PROCEDURE FOR FINELY DIVIDED MINERALS USED
IN PORTLAND CEMENT CONCRETE AND OTHER APPLICATIONS

DEFINITIONS

Department - Illinois Department of Transportation.

Bureau - Bureau of Materials and Physical Research, at 126 East Ash Street, Springfield, Illinois 62704-4766.

Finely Divided Mineral - A finely divided material which has cementitious or pozzolanic properties. Examples are fly ash, microsilica (silica fume), ground granulated blast-furnace (GGBF) slag, and high-reactivity metakaolin (HRM).

Manufacturer - A company that manufactures a finely divided mineral. The term Producer is also used.

Supplier - A company that supplies a finely divided mineral which it does not manufacture.

Source - The name and location of the manufacturing process from which the finely divided mineral is obtained.

Approved Source - A source that is approved by the Bureau to ship a finely divided mineral for immediate use on Department projects.

Unapproved Source - A source that ships a finely divided mineral which must be sampled, tested, and approved by the Bureau before it is used on Department projects.

Cement - Portland cement.

Fly Ash - A finely divided residue that results from the combustion of ground or powdered coal, transported from the combustion chamber by exhaust gas, collected by mechanical or electrical means, and stored in stockpiles or bins.

Microsilica - An amorphous silica of high silica content and purity possessing high pozzolanic activity.

Ground Granulated Blast-Furnace (GGBF) Slag - A glassy granular material, formed when molten blast-furnace slag is rapidly chilled, and then finely ground.

High-Reactivity Metakaolin (HRM) - A reactive aluminosilicate pozzolan formed by calcining purified kaolinite at a specific temperature range.

Reference Material - A portland cement used for the control mortar and corresponding test mortars, of a finely divided mineral, to determine its strength activity index.

Preliminary (PRE) Sample - A sample used to determine, in advance, if the finely divided mineral will comply with Department specifications.

Process Control (PRO) Sample - A sample used for the purpose of controlling production of finely divided minerals proposed for incorporation into Department projects.

Acceptance (ACC) Sample - A sample used for accepting/rejecting finely divided minerals prior to its use on Department projects and/or unassigned stock for future use on projects. The quantity represented by acceptance samples must be given.

Independent Assurance (IND) Sample - A sample used to provide an independent check on the reliability of the manufacturer's quality control program.

Investigation (INV) Sample - A destination sample used to verify the acceptability of a finely divided mineral from a source.

Grab Sample - A sample secured from a conveyor, from bulk storage, or from a bulk shipment in one operation.

Composite Sample - Combined grab samples taken at prescribed intervals over a period of time.

NIST - National Institute of Standards and Technology.

CCRL - Cement and Concrete Reference Laboratory.

ISO 9000 Series - A program of international quality management system standards developed by the International Organization for Standardization (ISO).

1.0 PURPOSE

To establish procedures whereby materials of mineral origin, furnished by a **Manufacturer** or **Supplier**, will be accepted for use on **Department** projects.

2.0 SCOPE

This procedure is available to all **Manufacturers** or **Suppliers** of domestic and foreign **Finely Divided Minerals**. **Sources** in North America may be **Approved** or **Unapproved**. **Sources** located outside of North American will not be given **Approved Source** status, and the procedures in Sections 5.1 and 5.3 shall apply.

3.0 SPECIFICATION REQUIREMENTS, SAMPLING, AND TEST PROCEDURES

- 3.1 **Finely Divided Minerals** used on **Department** projects shall meet the material requirements of the **Department's** "Standard Specifications for Road and Bridge Construction (January 1, 2007)" and current special provisions.

4.0 APPROVED SOURCE PROCEDURE

- 4.1 A **Manufacturer** or **Supplier** requesting **Source** approval of a **Finely Divided Mineral** shall provide the following to the **Bureau**:

- (1) The **Manufacturer's** or **Supplier's** name and location.
- (2) The **Source** name, location (station), and number of generating units.
- (3) The name of the **Finely Divided Mineral** and its class or grade.
- (4) A certification that the **Finely Divided Mineral** meets the applicable requirements of Section 3.0.
- (5) A 6-month testing history.
- (6) A copy of the **Manufacturer's** or **Supplier's** quality control program.
- (7) A copy of the last **CCRL** inspection report of the testing laboratory used by the **Manufacturer** or **Supplier** of the **Finely Divided Mineral**, with documentation of resolution of any discrepancies noted therein. The **Manufacturer** or **Supplier** of **HRM** or **Microsilica** shall provide a copy of the testing laboratory's **CCRL** inspection report and/or an **ISO 9000 Series** certificate.
- (8) A copy of the Material Safety Data Sheet (MSDS) for the **Finely Divided Mineral**.

At the time of application, the **Manufacturer** or **Supplier** shall obtain a **Preliminary (PRE) Grab Sample** of the **Finely Divided Mineral** from current production. The **Manufacturer** or **Supplier** shall split the **PRE Sample** and place one portion in an airtight container and deliver it to the **Bureau**. A sample of the **Reference Material** used by the **Manufacturer** or **Supplier** for testing shall be included. The **Manufacturer** or **Supplier** shall assume the cost to deliver the samples to the **Bureau**. The size of the **Bureau's** portion of the **PRE Sample**, and the **Reference Material**, shall not be less than 3 kg (6 lb.) each and the samples shall be properly identified as required in Attachment 1. The **Manufacturer** or **Supplier** shall test the retained portion of the **PRE Sample** for the standard physical and chemical properties listed in the applicable specification in Section 3.0 and deliver a copy of the test results to the **Bureau** for comparison.

The **Bureau** will test its portion of the **PRE Grab Sample** for conformance to Section 3.0. The **Bureau** will compare the results obtained by both laboratories to determine compliance with the allowable difference between two laboratories set forth in the precision statement of each test method. Additional split sample testing will be required if the test results obtained on the **PRE Grab Sample** do not comply with the specification requirements of this policy memorandum.

An inspector from the **Bureau** may conduct a scheduled visit to inspect the laboratory facilities designated by the **Manufacturer** or **Supplier** to test the **Finely Divided Mineral**; the **Source** manufacturing process, the **Source** storage facilities; and the quality control policies, procedures, and practices used by the **Manufacturer** or **Supplier**. The **Manufacturer** or **Supplier** shall be responsible for payment of transportation, per diem (meals), lodging, and incidental travel costs incurred by the **Department**.

The **Bureau** will notify the **Manufacturer** or **Supplier**, in writing, if the request for **Approved Source** status is granted or denied. A request may be denied if the **Manufacturer** or **Supplier** fails to meet the requirements of this policy memorandum, or for other reasons determined by the **Department**.

4.2 Quality Control Requirements for **Approved Sources**:

The **Manufacturer** or **Supplier** shall establish and maintain quality control policies and procedures for sampling and testing that are approved by the **Bureau**. The **Bureau** shall be notified of any changes in the **Manufacturer's** or **Supplier's** quality control program.

Testing laboratories used by the **Manufacturers** or **Suppliers** of **Fly Ash** or **GGBF Slag** shall participate in the **CCRL** pozzolan program of the **NIST**, which includes inspection of facilities and testing of comparative samples. As an alternative to the **CCRL** pozzolan program of the **NIST**, **Manufacturers** or **Suppliers** of **GGBF Slag** may participate in the **CCRL** cement program. Testing laboratories used by the **Manufacturers** or **Suppliers** of **Microsilica** or **HRM** shall participate in the **CCRL** pozzolan program of the **NIST** and/or shall have implemented a quality management system based on the **ISO 9000 Series** standards.

4.3 Reporting Requirements for **Approved Sources**:

The **Manufacturer** or **Supplier** shall deliver a test report to the **Bureau** which lists the results of all **Grab** and/or **Composite Samples** taken and tested for the specified reporting period.

For **Fly Ash**, the report shall be monthly, and shall be delivered no later than forty calendar days after the end of the month. If the **Fly Ash Source** is sampling more frequently than once per month according to ASTM C 311, then the report shall be delivered no later than forty calendar days after the end of the composite date. If the deadline falls on a Saturday, Sunday, or State Holiday, the deadline shall be the next work day.

For **GGBF Slag**, **HRM**, and **Microsilica**, the report shall be quarterly and shall be delivered no later than forty calendar days after the end of each quarter. For the purpose of the reports, the quarters shall end March 30, June 30, September 30, and December 31. If the deadline falls on a Saturday, Sunday, or State Holiday, the deadline shall be the next work day.

Sampling, testing, and reporting shall be done according to the applicable specification in Section 3.0.

4.4 Record Requirements for **Approved Sources**:

Records of production control tests shall be maintained by the **Manufacturer** or **Supplier** for a minimum period of 5 years, and shall be made available to the **Bureau** upon request.

Copies of bills of lading of quantities of **Finely Divided Minerals** shipped shall be maintained by the **Manufacturer** or **Supplier** for a minimum period of 3 years, and shall be made available to the **Bureau** upon request.

4.5 Sampling and Test Requirements for **Approved Sources**:

For **Fly Ash**, each February, May, August, and November, the **Supplier** shall obtain a **Process Control (PRO) Grab Sample**.

For **GGBF Slag, HRM, and Microsilica**, each January, April, July, and October, the **Manufacturer** or **Supplier** shall obtain a **PRO Grab Sample**.

The **PRO Grab Sample** shall be split for testing by the **Manufacturer** or **Supplier** and the **Bureau**. At this time, a sample of the current **Reference Material** used by the **Manufacturer** or **Supplier** for testing shall also be split.

The **Bureau** may require that more frequent **PRO Grab Samples** be obtained and tested. Increasing the sampling frequency may be required due to significant changes in the material or process, variations in test results between the **Bureau** and **Manufacturer** or **Supplier**, field test results, or other reasons as determined by the **Bureau**. The **Bureau** samples shall be placed in airtight containers, properly identified on form BMPR CM01 (www.dot.il.gov/materials/materialforms.html), and delivered to the **Bureau** no later than the last work day of the month. Each **Finely Divided Mineral** sample and **Reference Material** sample shall not be less than 3 kg (6 lb).

The **Manufacturer** or **Supplier** shall test the retained portion of each **PRO Sample**, using the retained portion of the **Reference Material**, for the standard physical and chemical properties listed in the applicable specification in Section 3.0. When all tests are completed, the **Manufacturer** or **Supplier** shall record the test results on a report form that identifies the sample as a **PRO Sample**, and deliver the report to the **Bureau** no later than the last work day of the following month from the date of sample.

The test results obtained by the **Manufacturer** or **Supplier** and the **Bureau** on all split samples will be compared for compliance with the allowable differences for two laboratories set forth in the precision statement of each test method and for compliance with Section 3.0. If significant differences exist in the split sample test results, the **Department** will investigate sampling and test procedures, or require additional comparative sampling to determine the cause of the variation.

4.6 **Department** Inspections of **Approved Sources**:

An inspector from the **Bureau** may conduct unscheduled visits, at **Department** expense, to each **Approved Source** or one of its terminals. During this visit, the inspector will either take or witness the taking of a random **Independent Assurance (IND) Grab Sample**. The inspector will split the sample and deliver an equal portion to the **Manufacturer** or **Supplier**. The **Manufacturer** or **Supplier** shall test the retained portion of the split sample for the standard physical and chemical properties

listed in the applicable specification and deliver the test results to the **Bureau**, as specified in Section 4.5, for comparison and compliance with Section 3.0.

Random **Investigation (INV) Samples** of the **Finely Divided Minerals** and the project **Cement** will be obtained at final destination by a representative of the **Department**. The representative will either take or witness the taking of the **INV**

Samples. **INV Samples** will be **Grab Samples** and shall not be less than 3 kg (6 lb). (Note: **Cement** samples will be taken according to ASTM C 183). The

sampling location and frequency for obtaining **INV Samples** will be determined by the **Bureau** in consultation with the district offices.

The **Bureau** will test **INV Samples** to ascertain the results of **Finely Divided Mineral-project Cement** combinations. To verify that **Finely Divided Minerals** shipped from **Approved Sources** meet the requirements of Section 3.0, the **Bureau** will test **INV Samples** with the appropriate **Reference Material**.

4.7 Revocation of **Approved Source** Status:

Failure of a **Manufacturer** or **Supplier** to meet the requirements of Sections 3.0 and 4.0 of this policy memorandum will be sufficient cause to revoke **Approved Source** status. However, a total of three late submittals in a twelve month period for any of the following: test report (**Grab** or **Composite Samples**), **PRO Sample**, or **PRO** test results will be permitted. Revocation will occur if a fourth late submittal occurs in a twelve month period. The **Manufacturer** will be notified in writing when the third late submittal in a twelve month period occurs.

Failure to resolve significant differences in testing, as indicated by the test results obtained on **PRO** or **IND Samples** split with the **Manufacturer** or **Supplier** will be sufficient cause to revoke **Approved Source** status.

Failure of the testing laboratory, used by the **Manufacturer** or **Supplier** of a **Finely Divided Mineral**, to satisfactorily resolve the discrepancies noted in the **CCRL** inspection report and/or to maintain a quality management system based on the **ISO 9000 Series** will be sufficient cause to revoke **Approved Source** status.

Revocation of **Approved Source** status will be reported to the **Manufacturer** or **Supplier** in writing. The **Manufacturer** or **Supplier** may not re-apply for **Approved Source** status until 30 days have elapsed from the date of the written notice of revocation.

5.0 UNAPPROVED SOURCE PROCEDURE

5.1 A **Manufacturer** or **Supplier** requesting approval of a **Finely Divided Mineral** from an **Unapproved Source** shall provide the following to the **Bureau**:

- (1) The **Manufacturer's** or **Supplier's** name and location.
- (2) The **Source** name, location (station), and number of generating units.
- (3) The name of the **Finely Divided Mineral** and its class or grade.

- (4) A current test report, in English, which indicates the standard physical and chemical composition of the **Finely Divided Mineral** as per Section 3.0.
- (5) The transportation method and location at which an inspector from the **Bureau** will be able to obtain **Acceptance (ACC) Samples**.
- (6) If requested by the **Bureau**, the **Manufacturer** or **Supplier** shall deliver to the **Bureau** a 24-hr **Composite Preliminary (PRE) Sample** of the **Finely Divided Mineral** from current shipments. The **Manufacturer** or **Supplier** shall assume the cost to deliver it to the **Bureau**. The size of the **PRE Sample** shall not be less than 3 kg (6 lb) and the sample shall be properly identified as required in Attachment 1.

5.2 Sampling and Test Requirements for **Unapproved Sources** in North America:

- (1) **Finely Divided Minerals** from an **Unapproved Source** will be sampled, tested, and approved by the **Bureau** before use on **Department** projects. The **Bureau** has the option to affix a seal to secure **Finely Divided Minerals** in storage (e.g. silo, truck, railroad car, or barge) until the **Bureau's** testing is completed.
- (2) Upon arrival of the **Finely Divided Mineral** to Illinois, an inspector from the **Bureau** will obtain **Acceptance (ACC) Grab Samples** according to the applicable specifications. The **Bureau** will determine the number of representative samples required.
- (3) The **Manufacturer** or **Supplier** may request the **Bureau** to sample the **Finely Divided Mineral** prior to arrival in Illinois. In the event the request is approved, the **Manufacturer** or **Supplier** shall be responsible for payment of transportation, per diem (meals), lodging, and incidental travel costs incurred by the **Department** inspector. If the **Department** determines that it lacks the resources to accomplish out-of-state inspection, the **Finely Divided Mineral** may be sampled and tested according to the procedures in Section 5.3.
- (4) **Acceptance (ACC) Samples** will be tested by the **Bureau** for conformance to Section 3.0, and to approve the **Finely Divided Mineral** for use on **Department** projects.
- (5) **Random Investigation (INV) Samples** of **Finely Divided Minerals** may be obtained at final destination by a representative of the **Department**. The representative will either take or witness the taking of the **INV Samples**. **INV Samples** will be **Grab Samples** and will be taken according to the applicable specification. The sampling location and frequency for obtaining **INV Samples** will be determined by the **Bureau** in consultation with the district offices. The **Bureau** will use **INV Samples** to verify that the **Finely Divided Mineral** shipped meets the requirements of Section 3.0.

5.3 Sampling and Test Requirements for **Unapproved Sources** Located Outside North America:

An agent of the importer shall obtain an **Independent Assurance (IND) Grab Sample** from each barge of foreign **Finely Divided Mineral** loaded at the port of entry and destined for Illinois.

The agent shall split each barge **Grab Sample** and mail one portion to the **Bureau**. The other portion shall be mailed to the importer's testing laboratory that is approved by the **Department**. The importer of the **Finely Divided Mineral** shall be responsible for all sampling and mailing costs.

The importer's laboratory shall test its portion of each barge **Grab Sample** for the standard physical requirements of the applicable specifications. One random barge **Grab Sample**, representing the **Finely Divided Mineral** in each hold of the vessel shall be tested for chemical composition.

Upon completion of the tests, the importer shall deliver to the **Bureau** a certification that states the **Finely Divided Mineral** in the vessel unloaded at the port of entry has been tested by the importer, and complies with the applicable specifications. Attached to the certification shall be a test report of all barge samples. The report shall include the name of the vessel, the source of the **Finely Divided Mineral**, the barge number, the hold number, the date the sample was taken, the quantity of **Finely Divided Mineral** in the barge, and the physical and chemical test results obtained on the samples.

The importer shall immediately notify the **Bureau** if a barge sample fails to meet the applicable specification requirements.

The **Bureau** will review the certification and compare the importer's test data to the test data obtained by the **Bureau** on its portion of each split sample.

When the certification and the accompanying test report are examined and determined to be correct, the **Bureau** will notify the importer and the district offices that the **Finely Divided Mineral** is approved for state projects.

Random Investigation (INV) Samples, from one or more barges, may be taken by a **Department** inspector when the barges arrive at the Illinois terminal(s).

The **Department** will reject any foreign **Finely Divided Mineral** tested by the **Bureau**, or the importer, that does not meet the specification requirements. The **Department** may reject any barge of **Finely Divided Mineral** wherein the differences in test values, obtained by the **Department** and the importer on the split sample, exceeds the multilaboratory precision of the test method, but the **Finely Divided Mineral** is within specifications.

Alternative proposals to the sampling and test requirements stated in this section will be considered for **Finely Divided Minerals** which have an acceptable quality history, and which have previously been approved by the **Department**. Requests shall be directed to the **Bureau of Materials and Physical Research** for approval.

6.0 ACCEPTANCE OF FINELY DIVIDED MINERALS

- 6.1 **Finely Divided Minerals** will be accepted according to the **Department's** current "Standard Specifications for Road and Bridge Construction," current special provisions, and this policy memorandum.
- 6.2 The **Bureau** will maintain and circulate a current list of **Approved Sources** of **Finely Divided Minerals** which meet the requirements of this policy memorandum. This list will include the name, location, and Producer/Supplier Number of each approved **Manufacturer** or **Supplier** of **Finely Divided Minerals**. These **Manufacturers** or **Suppliers** may ship **Finely Divided Minerals** for immediate use on **Department** projects.
- 6.3 **Finely Divided Minerals** from **Unapproved Sources** will be approved by the **Bureau** before use on **Department** projects.

7.0 REJECTION OF FINELY DIVIDED MINERALS

- 7.1 A **Finely Divided Mineral** that fails to conform to the requirements of Section 3.0 of this policy memorandum shall be rejected for use on **Department** projects.
- 7.2 The **Bureau** will notify the **Manufacturer** or **Supplier** when a **Finely Divided Mineral** is rejected for use on **Department** projects.



David L. Lippert, P.E.
Acting Engineer of Materials
and Physical Research

Attachment

This policy memorandum supersedes Policy Memorandum 06-03 dated January 1, 2006.
--

DAD/dt

Vacuum Type Bulk Cement Sampler

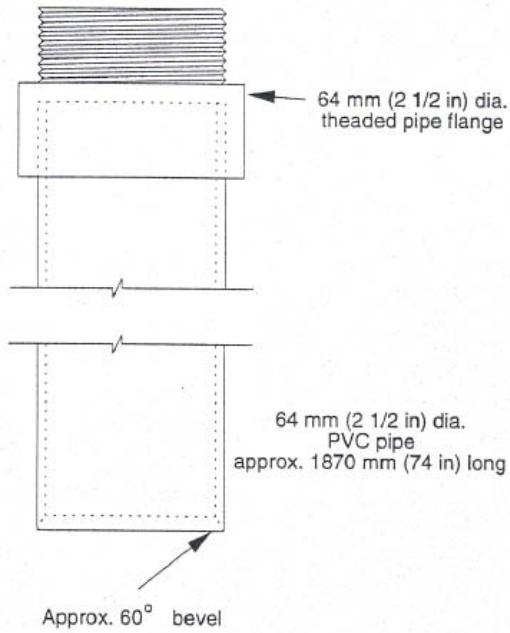
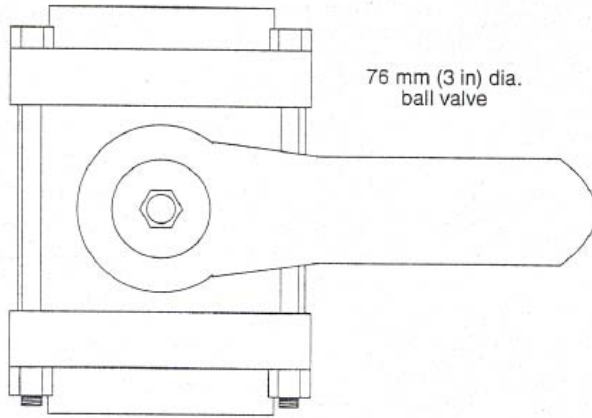

Drop Type Bulk Cement Sampler

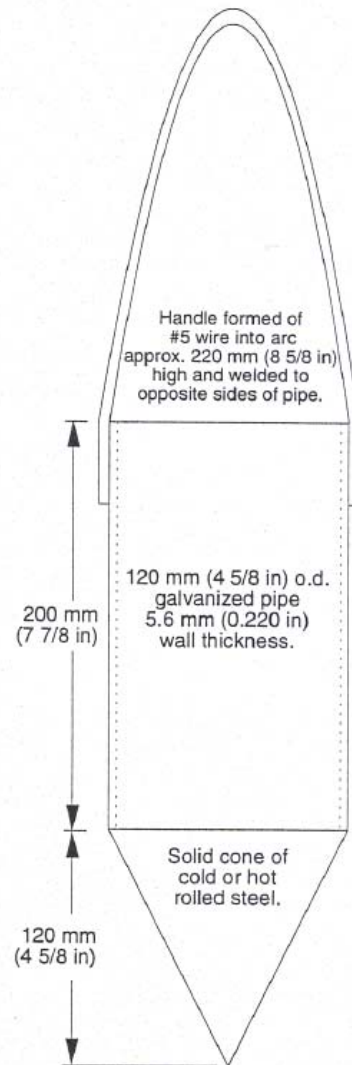

Note:
Total mass weight of sampler not less than 6 kg (13 lb)

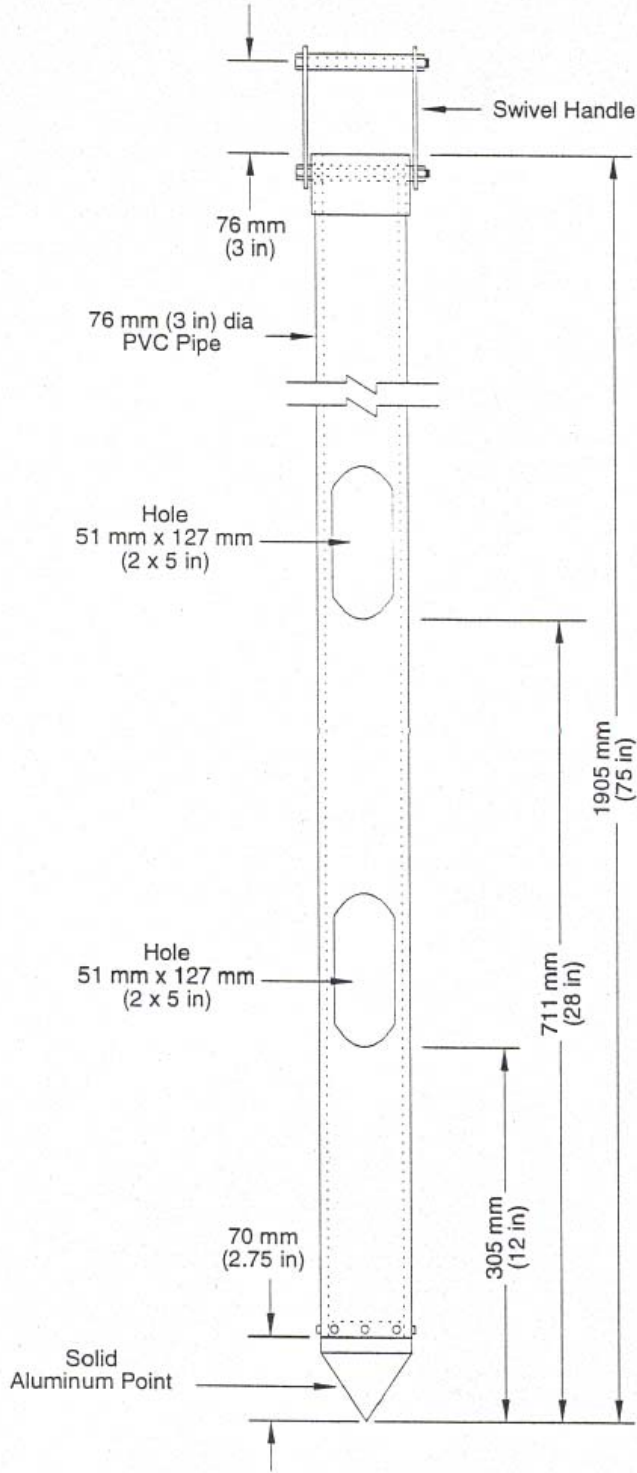

Tube Type Bulk Cement Sampler

State of Illinois
Department of Transportation
Division of Aeronautics

POLICY MEMORANDUM

April 1, 2010

Springfield

Number: **87-3**

TO: CONSULTING ENGINEERS

SUBJECT: MIX DESIGN, TEST BATCH, QUALITY CONTROL, AND ACCEPTANCE TESTING OF PCC PAVEMENT MIXTURE

I. SCOPE

This Policy Memorandum addresses the Mix Design, Test Batch, Quality Control and Acceptance Testing of PCC pavement mixtures specified by Item 501, Portland Cement Concrete Pavement, in accordance with the Standard Specifications for Construction of Airports, Special Provisions, and policies of the Division of Aeronautics.

II. MIX DESIGN

Prior to the start of paving operations and after approval by the Division of Aeronautics (IDOA) of all materials to be used in the manufacture of the concrete, the contractor shall provide a preliminary mix design(s) for evaluation at the Test Batch. The mix design shall indicate saturated surface dry batch weights per cubic yard for each material component. In addition, each material component, including chemical admixtures, shall be identified by the IDOT material code number, the IDOT producer code number, and the producer name and location. Saturated surface dry and oven dry specific gravities, as well as absorption values, for each proposed aggregate to be used in the mix shall be indicated on the mix design. When requested in writing by the contractor, the Engineer will recommend a preliminary mix design for evaluation at the Test Batch.

The Mix Design and the contractor's approved Job Mix Formula (JMF) will be issued by our office subject to verification of the mix by strength tests obtained from mix prepared from a Test Batch(es) according to the approved JMF. The water-cementitious ratio established from the approved test batch is the maximum water-cementitious ratio allowed during production paving. Whether the contractor selects his own mix design or chooses to use the mix design recommended by the Division, the contractor is responsible for the mix design, as well as the manufacture and placement of the mix.

III. TEST BATCH

At least 28 days prior to the start of production, the contractor and/or producer shall prepare a Test Batch under the direction of the Engineer. The Test Batch shall be prepared at the concrete plant proposed for use in the production of the concrete mix for

the project and shall be in accordance with the approved Job Mix Formula (JMF). When approved by the Engineer, the Test Batch may be prepared at a different plant provided that the same materials specified in the JMF are used. The plant shall have been surveyed and approved by the Engineer prior to preparation of the Test Batch. As required by these Special Provisions, the contractor shall provide Quality Control for production of the concrete. The contractor shall have his Quality Control Manager and a representative of the contractor familiar with the paving operation, present at the Test Batch preparation. The Test Batch shall be prepared as follows:

A. Proportioning

Prior to preparation of the mix, the Proportioning Technician shall perform a minimum of two (2) gradation analysis and two (2) moisture tests on each aggregate used. The gradation analysis shall be reported on form AER-12. From this data, the JMF shall be adjusted for moisture, in accordance with form AER-12. A microwave type moisture probe (or equal) may be allowed to adjust proportions for sand moisture when approved by the Engineer.

B. Preparation of the Mix:

- 1.) Prepare a Test Batch that is at least one-half (1/2) the manufacturer's rated capacity of the mixing drum (in cubic yards). The Test Batch shall be prepared with the approved JMF, adjusted for moisture.
- 2.) Mixing requirements shall be:
 - a.) Central Mix Plant: Mixing time shall be a minimum of 90 seconds. If transit mixer trucks are used to transport the mix, the mix shall be agitated, after mixing, at 2-5 RPM for the approximate time anticipated between batching at the plant and deposit of the concrete in the forms. If non-mixing trucks are used to transport the mix, the mix shall remain in the central mixer with no mixing or agitation for the approximate time anticipated from when the water contacts the cement and deposit of the concrete in the forms.
 - b.) Transit Mix Plant: Mixing shall consist of 70-100 Revolutions @ 5-16 RPM. After initial mixing, agitate mix at 2-5 RPM for the approximate time anticipated between batching at the plant and deposit of the concrete in the forms.
- 3.) Slump and Air: If the air content after aging is $6.0\% \pm 1.5\%$ and provides the required workability for paving, the contractor will make cylinders for testing at 3, 7, 14 and 28 days. If the slump is below that required for placement, the contractor may add additional water to increase the slump as necessary up to the maximum water/cement ratio (or water/cementitious material) ratio listed herein. Additional mixing of at least 40 Revolutions will be required with each addition of water. Cylinders and/or beams will be made for testing at 3, 7, 14 and 28 days when the slump is obtained, at $6.0\% \pm 1.5\%$ air content. The water/cement ratio (or water/cementitious material) ratio cannot exceed 0.44 based on actual batch weights when 501-3.6(A) proportions is specified, and 0.42 when 501-3.6(B) proportions is specified.

- 4.) The Proportioning Technician shall complete Form AER M-7, Plastic Concrete Air, Slump and Quantity and Form AER M-6, Concrete Moisture Determination (Adjusted Oven Dry Method), to be given to the Resident Engineer after completion of the Test Batch. The Flask Method, Dunagan Method, and Pycnometer Jar Method are also acceptable test methods for the determination of aggregate moisture.
- 5.) The Resident Engineer and contractor shall each independently complete Form AER M-4, Concrete Plant Production, Mix Verification.
- 6.) The concrete test cylinders and/or beams shall be tested at 3, 7, 14 and 28 days to establish a growth curve of concrete strength vs. age. The compressive strength shall be at least 800 psi, over the specified strength, at 28 days. Flexural strength concrete shall have at least 100 psi over the specified strength at 28 days.

IV. QUALITY CONTROL

Quality control testing is the responsibility of the contractor and must be performed by qualified testing personnel approved by the Engineer. The proportioning technician shall be PCC Level II certified by the testing firm must perform his or her duties on a full time basis whenever concrete is produced for an IDOA project.

The proportioning technician shall perform the duties as outlined in the Division of Highways latest Manual of Instructions for Concrete Proportioning and Testing and as outlined as follows. These duties as outlined are not necessarily all inclusive and may include other duties as required by the specifications, special provisions, etc.

If a QC or QA test for slump, air content, or mix temperature fails to meet the requirements of the specifications the contractor shall reject the batch. In the case of a failing test of the air content, the contractor may make adjustments to the concrete to bring the air content into compliance with the specification. Adjustments are subject to the time limitations of 1 hour from time of batching when the concrete is transported in mixer trucks. Time limitations shall be increased by 30 minutes when the concrete mixture contains a retarding admixture. When concrete has been rejected due to failing test results, the contractor shall continue to run tests for the failed test parameter until at least 3 consecutive passing tests are achieved. This testing is in addition to the normal QC and QA testing.

A. Duties of the Proportioning Technician:

- 1.) Check and maintain shipment tickets of each material used in the manufacture of the concrete. These tickets are to be given to the Resident Engineer for each day's production of concrete. The aggregates shall indicate the quality on the ticket and a statement that the coarse aggregate is a non "D" cracking (freeze-thaw rated by IDOT) aggregate. In lieu of having these statements on each ticket, the contractor may use the Division's Aggregate Certification of Compliance form, or supply the Resident Engineer with a certification letter indicating the stone quality and statement of non "D" cracking compliance.

- 2.) Inspect and maintain proper storage of all aggregates and materials daily.
- 3.) Perform at least one (1) sieve analysis for each aggregate daily.
- 4.) Inspect all weighing or measuring devices daily.
- 5.) Twice daily check the actual weighing or measuring of aggregates, cement, water, and admixtures for conformance to adjusted batch proportions. Record data on Form AER-4, Concrete Plant Production, Mix Verification, and calculate the water/cement (or water/cementitious material) ratio.
- 6.) See that the volume of the batch does not exceed the allowable capacity of the mixer and that the proper mixing time is used.
- 7.) Make at least two (2) moisture tests of each aggregate daily and correct batch weights as required.
- 8.) Adjust the dosage rates of the admixtures as required to meet concrete temperature changes and paving conditions.
- 9.) Complete AER M-7, Concrete Air, Slump and Quantity, and Form AER-4, Concrete Plant Production, Mix Verification for each day's production and deliver same to the Resident Engineer at the end of the day for which the data pertains. Provide to the Resident Engineer load tickets for all aggregates, cement, and admixtures used in the mix.

The Resident Engineer will also be required to visit the plant twice daily on a random basis to record actual batch weights and complete Form AER-4, Concrete Plant Production, Mix Verification. Forms AER-4, AER -7, and AER -12 shall be submitted to the R.E. on a daily basis and then faxed by the R.E. to the Division of Aeronautics daily. (FAX is (217) 558-1328)

V. ACCEPTANCE TESTING

As required by Item 501-5.3 of the Standard Specifications, acceptance and payment of the final pavement is based on the strength of either cylinders or beams taken at random during the time of construction. The pavement shall be divided into Lots of 1200 cubic yards with sublots of 300 cubic yards each. The final subplot of the project shall be separated into an additional subplot if the concrete quantity is greater than or equal to 150.0 cubic yards. Otherwise, this remaining quantity shall be incorporated into the previous subplot.

One random sample (two cylinders or one beam) shall be obtained from each subplot for testing at 28 days to calculate final payment. At the time a subplot sample is taken, one (1) slump and one (1) air test shall be taken.

In addition to the above described sample frequency, three (3), seven (7) and fourteen (14) day tests shall be taken. The Engineer may require additional tests to maintain Quality Control.

Lots and sublots shall not be separated by mix design or day of paving if the project is using more than one mix design. The grouping of Lots and sublots is to be done solely by the quantity of cubic yards poured on the project.

Steven J. Long, P.E.
Acting Chief Engineer

Supersedes Policy Memorandum 87-3, dated July 31, 2004.

State of Illinois
Department of Transportation
Division of Aeronautics

POLICY MEMORANDUM

August 22, 2016

Springfield

Number: **90-1**

TO: CONSULTING ENGINEERS

SUBJECT: Resampling and Retesting of PCC Pavement

I. PURPOSE

This Policy Memorandum outlines the procedure for resampling and retesting of individual Lots of PCC Pavement for the determination of final Price Adjustment as permitted by the Special Provisions for Item 501 Portland Cement Concrete Pavement (Plain and Reinforced).

II. RESAMPLING AND RETESTING

If the contractor should request the resampling and retesting of a LOT, he must notify the Engineer in writing within 24 hours of receiving the written test results and payment results for the LOT in question. The entire LOT must be resampled (no selective resampling of individual sublots will be allowed) and the contractor is not allowed to take additional cores. Once approval to resample has been granted the contractor shall resample within five (5) working days. The Engineer will select random locations from each SUBLOT of the LOT in question and direct the contractor to drill two (2) 4 inch or 6 inch diameter cores from each location. The cores shall be obtained, cured and tested in accordance with ASTM C42, Obtaining and Testing Drilled Cores and Sawed Beams of Concrete. The Engineer will take possession of the cores once they have been cut by the contractor.

III. CALCULATION FOR PRICE ADJUSTMENT

1. When Compressive Test Specification (501-3.6(A) Proportions) is specified. The two (2) specimens from each SUBLOT shall be averaged to constitute one SUBLOT sample. The Percent Within Limits (PWL) for the LOT shall then be calculated in accordance with Item 501-5.3, Price Adjustment, of the Special Provisions using the sampled core compressive strengths and the Compressive Test formula. The final Price Adjustment shall be based on the PWL calculated using the sampled core compressive strengths. The test results of the resampled pavement are final. All costs associated with resampling, including, but not limited to testing, curing, and coring the concrete samples shall be borne by the contractor, regardless as to whether the test results increase or decrease calculated payment quantity of concrete pavement.

2. When Flexural Test Specification (501-3.6(B) Proportions) is specified. The two (2) specimens from each SUBLOT shall be averaged to constitute one SUBLOT sample. The SUBLOT samples shall then be averaged to obtain a LOT average. In order for the contractor to increase concrete payment quantity back to 100%, the LOT average shall be at least 6500 psi, and no individual SUBLOT sample shall be less than 6000 psi. Both the LOT average and SUBLOT sample strength requirements must be met in order for the concrete payment quantity to change back to 100%. If both requirements are not met, then the original concrete payment quantity calculated based on the Percent Within Limits (PWL) as outlined in 501-5.3, Price Adjustment, of the Special Provisions shall still apply. The test results of the resampled pavement are final. All costs associated with resampling, including, but not limited to testing, curing, and coring the concrete samples shall be borne by the contractor, regardless as to whether the test results increase or decrease calculated payment quantity of concrete pavement.

Steven J. Long,
P.E. Acting Chief
Engineer

Supersedes Policy Memorandum 90-1, dated January 1, 2004

**Illinois Department of Transportation
Division of Aeronautics
Materials Section**

POLICY MEMORANDUM

January 1, 2004

Springfield

Number 95-1

TO: CONSULTING ENGINEERS

SUBJECT: FIELD TEST PROCEDURES FOR MIXER PERFORMANCE AND CONCRETE UNIFORMITY TESTS

I. SCOPE

These methods describe the procedures for obtaining and testing representative samples of fresh concrete in the field to determine the consistency and mixer efficiency of stationary mixers at different mixing time periods.

The concrete produced during the mixing time investigation and not used in the test program may be incorporated in the project provided it conforms to the Standard Specifications for Construction of Airports.

A maximum of two mixing times shall be considered by the Department.

The contractor shall provide all of the necessary equipment and personnel to perform the tests and the Department will observe the testing.

II. APPARATUS REQUIRED

- a. Three (3) air meters conforming to the requirements of ASTM C231 or ASTM C173.
- b. Three (3) slump cone kits conforming to ASTM C143.
- c. One (1) No. 4 sieve having a minimum screen area of 2 sq. ft. The sieve shall conform to the requirements of AASHTO M92.
- d. One (1) platform scale graduated in tenths of a pound having a capacity sufficient to perform tests herein after specified.
- e. One (1) hydraulic or mechanical testing machine conforming to the requirements of the specified testing method for the project (ASTM C39 or ASTM C78).

- f. Flexural strength specimen forms as required. The forms shall be nominally 6x6x30 inch. Means shall be provided for securing the base plate firmly to the mold. The inside surfaces of the mold shall be smooth and free from holes, indentations, or ridges. The sides, bottom, and ends shall be at right angles and shall be straight and true so that the specimens will not be warped. Maximum variation from the nominal cross-section shall not exceed 1/8 inch. The assembled mold and base plate shall be lightly coated with mineral oil or other approved form release oil before use. Compressive strength specimens shall be 6x12 inch and prepared in accordance with ASTM C31.
- g. Sufficient water tanks for curing specimens as required by ASTM C31.
- h. Small tools such as shovels, scoops, buckets, etc., and water shall be furnished, as required.

III. MIXER

The mixer for which the mixing time is to be evaluated shall conform to the applicable sections of the Standard Specifications for Construction of Airports.

IV. MIXING TIME REQUIREMENTS

The minimum mixing time to be evaluated shall be specified in the Standard Specifications for Construction of Airports.

V. PROCEDURE

A minimum of ten (10) batches per drum shall be tested and evaluated for each original reduced mixing time request. Check tests shall consist of three (3) batches.

If the request is for a new, twin drum mixer, ten (10) batches shall be tested for the first drum and three (3) for the second drum.

Check tests are required if the mixer is moved, major maintenance performed, or if the source or type of aggregate has changed. A minimum frequency of check tests shall be one (1) per year.

a. Mixing Time

The mixing time and batch size to be evaluated shall be proposed by the contractor. The mixing time shall begin when all solid materials are in the mixing drum. The mixer timer shall register or indicate accurately the mixing time and a tolerance of two (2) seconds will be permitted.

If approved by the Engineer, minor adjustments in admixture dosage and water content will be allowed to account for weather conditions, provided that the maximum w/c ratio is not exceeded.

b. Sampling

At the conclusion of the mixing cycle, the mixer shall be discharged and appropriate samples obtained from the first, middle, and last third portions of the batch. Any appropriate method may be used, provided the samples are representative of the respective portions and not the very ends of the batch.

As an alternative, the mixer may be stopped, and the samples removed by any suitable means at equally spaced points from the front to the back of the drum.

c. Testing.

1. Each third portion of the batch shall be tested simultaneously. The Contractor shall provide sufficient personnel to meet this requirement. The Contractor personnel performing the testing shall be Level I PCC Technicians or Concrete Testers. However, a Level I PCC Technician shall be provided to supervise the Concrete Tester.
2. From each third portion of the batch the mass (weight) of the concrete in one air meter measuring bowl shall be determined.
3. The air content of each third portion of the batch shall be determined according to ASTM C231 or ASTM C173. The air content shall be the arithmetic average of two (2) tests from each third portion of the batch.
4. The slump of each third portion of the batch shall be determined according to ASTM C143. The slump shall be the arithmetic average of two (2) tests from each third portion of the batch.
5. Flexural strength specimen(s) (two (2) breaks required) or two (2) compressive strength specimens shall be prepared from each third portion of the batch according to ASTM C31. Flexural strength specimen(s) (two (2) breaks required) shall be tested according to ASTM C78 at seven (7) days of age. Compressive strength specimens shall be tested according to ASTM C39 at seven (7) days of age.
6. The contents from the weighed air meter measuring bowl shall be washed over a No. 4 sieve. Shake as much water as possible from the material retained on the sieve and then weigh the material. The coarse aggregate content (portion of mass (weight) of sample retained on a No. 4 sieve), expressed as a percent, shall be calculated.

VI. CONCRETE UNIFORMITY REQUIREMENTS

- a. Test results from each third portion of the batch shall be compared to one another according to Table 1. Each batch shall be evaluated individually.
- b. Mixer performance tests consisting of ten (10) batches: If more than seven (7) tests out of the total or more than three (3) in any one criteria are not in compliance with the uniformity requirements (air content, slump, coarse aggregate content, and strength), a reduced mixing time will not be granted.
- c. Mixer performance tests consisting of three (3) batches: If more than three (3) tests out of the total are not in compliance with the uniformity requirements, a full ten (10) batch investigation shall be required.

Table 1. Requirements for Uniformity of Concrete

Test	Requirement (Note 1)
Air Content, percent by volume of concrete	1.0 (Note 2)
Slump, inch	1.0 (Note 3)
Coarse aggregate content, portion by weight of each sample retained on the No. 4 sieve, percent	6.0
Average flexural or compressive strength at 7 days for each sample based on average strength of all comparative test specimens, percent	7.5 (Note 4)

Note 1. Expressed as maximum permissible difference in results of tests of samples taken from three locations in the concrete batch.

Note 2. The average air content sample shall be the arithmetic average of two (2) tests.

Note 3. The average slump sample shall be the arithmetic average of two (2) tests.

Note 4. The average flexural strength of each sample shall be the arithmetic average of two (2) beam breaks. The average compressive strength of each sample shall be the arithmetic average of two (2) cylinder breaks.

Steven J. Long, P.E.
Acting Chief Engineer

Supersedes Policy Memorandum 95-1 dated January 1, 1995

State of Illinois Department of
Transportation Division of
Aeronautics

POLICY MEMORANDUM

June 22, 2018

Springfield, Illinois

Number 97-2

TO: CONSULTING ENGINEERS

SUBJECT: PAVEMENT MARKING PAINT ACCEPTANCE

I. SCOPE

The purpose of this policy memorandum is to define the procedure for acceptance of pavement marking paint.

II. RESIDENT ENGINEER'S DUTIES

The Resident Engineer shall follow the acceptance procedure outlined as follows:

- A. Require the contractor to furnish the name of the paint manufacturer, IDOT Test I.D. number and the Batch/Lot number proposed for use prior to beginning work. Notify the I.D.A. Materials Certification Engineer when this information is available.
- B. Require the manufacturer's certification before painting begins. Check the certification for compliance to the contract specifications.
 1. The certification shall be issued from the manufacturer and shall include the specification and the batch number.
 2. The paint containers shall have the manufacturer's name, the specification and the batch number matching the certification.
- C. If no batch number is indicated on the certification or containers, sample the paint according to the procedure for the corresponding paint type.
- D. If the I.D.A. Engineer of Materials indicates that batch number has not been previously sampled and tested, sample the paint according to the procedure for the corresponding paint type. The Division of Aeronautics will provide paint cans upon request by the Resident Engineer. Samples will only be taken in new epoxy lined cans and lids so that the paint will not be contaminated. It is important to seal the sample container immediately with the paint can lid to prevent the loss of volatile solvents.

Mark the sample cans with the paint color, manufacturer's name, and batch number. The paint samples and manufacturer's certification shall be placed in the mail or delivered within 24 hours after sampling. Address or deliver the samples to the Material's Certification Engineer at:

Illinois Department of Transportation
Division of Aeronautics
One Langhorne Bond Drive
Springfield, Illinois 62707

Sampling Procedures for Each Paint Type:

1. Waterborne or Solvent Base Paints
 - a. A sample consists of one one-pint cans taken per batch number. Before drawing samples, the contents of the component's container must be thoroughly mixed to make certain that any settled portion is fully dispersed.
 - b. Be sure to indicate to the contractor that acceptance of material is based upon a passing test of the paint material.

2. Epoxy Paint
 - a. Take separate one-pint samples of each paint component prior to marking. Before drawing samples, the contents of each component's container must be thoroughly mixed to make certain that any settled portion is fully dispersed. **Do not combine the two components or sample from the spray nozzle.**
 - b. Be sure to indicate to the contractor that acceptance of material is based upon a passing test of the paint material.

III. TESTING

The paint will be tested for acceptance by the IDOT Bureau of Materials and Physical Research for conformance to the contract specifications.



Alan D. Mlacnik, P.E.
Chief Engineer

Supersedes policy memorandum 97-2 dated January 1, 2004

State of Illinois
Department of Transportation
Division of Aeronautics

POLICY MEMORANDUM

January 1, 2004

Springfield, Illinois

Number: 2001-1

TO: CONTRACTORS

SUBJECT: REQUIREMENTS FOR COLD WEATHER CONCRETING

I. PURPOSE

- A. This policy memorandum outlines the minimum requirements for cold weather concreting. Cold weather is defined as whenever the average ambient air temperature during day or night drops below 40°F.

II. COLD WEATHER CONCRETING PLAN

- A. The contractor shall submit a cold weather concreting plan to the Engineer for approval. Cold weather concreting operations are not allowed to proceed until the contractor's cold weather concreting plan has been approved by the Engineer.
- B. The contractor's plan shall be in compliance with this memorandum and shall address, as a minimum, the following:
1. Concrete Mix Manufacturing
 2. Concrete Mix Temperature Monitoring
 3. Base Preparation
 4. Concrete Curing and Protection
 5. In Place Concrete Temperature Monitoring
 6. Strength Test Specimens

III. MINIMUM REQUIREMENTS

A. Concrete Mix Manufacturing

1. The contractor must make the necessary adjustments so that the concrete temperature is maintained from 50°F to 90°F for placement. Acceptable methods include:
 - a) Heating the mixing water Note: If the mixing water is to be heated to a temperature above 100°F, the contractor must include a mixing sequence plan to indicate the order that each component of the mix is to be charged into the mixer.

- b) Heating the aggregates Note: The exact method of heating the aggregates shall be included as part of the cold weather concreting plan. Aggregates must be free of ice and frozen lumps. To avoid the possibility of a quick or flash set of the concrete, when either the water or aggregates are heated to above 100°F, they should be combined in the mixer first before the cement is added.

B. Concrete Mix Temperature

1. The contractor shall monitor the mix temperature at the plant and prior to placement in the forms. Mix that does not meet the temperature requirement of 50°F to 90°F shall be rejected for use on the project.

C. Base Preparation

1. Paving or placing concrete on a frozen base, subbase, or subgrade is prohibited.
2. The base, subbase, or subgrade on which the concrete is to be placed shall be thawed and heated to at least 40°F. The method by which the base subbase or subgrade is to be heated shall be indicated in the contractor's cold weather concreting plan. Insulating blankets or heated enclosures may be required.

D. Concrete Protection and Curing

1. In addition to the curing options available in article 501-3.17 (a) (b), (c), and (d) of the Standard Specifications for Construction of Airports, the contractor shall protect the concrete in such a manner as to maintain a concrete temperature of at least 50°F for 10 days.
2. The method of concrete protection shall be by use of insulating layer or heated enclosure around the concrete. The method of protection shall be indicated in the contractor's cold weather concreting plan. When insulating layers are to be used, the thermal resistance to heat transfer (R Value in °F*hr*ft²/BTU) of the insulation material selected, shall be appropriate for the slab thickness being constructed and shall be indicated in the cold weather concreting plan.
3. Appendix A shows a chart and table taken from the American Concrete Institute specification, ACI 306 R Cold Weather Concreting, which may be used by the contractor in selecting the proper insulation (R Value) and insulating material which may be used.

E. In-Place Concrete Temperature Monitoring

1. Once the concrete is in place, the protection method used, must ensure that the concrete temperature does not fall below 50°F for the time period specified in Section (D. 1.) of this Policy Memorandum (10 days).
2. The concrete temperature on the surface and below the surface must be monitored and recorded by the contractor for the duration of the protection period in Section (D. 1.).
3. After the concrete has hardened, surface temperature can be checked with special surface thermometers or with an ordinary thermometer that is kept covered with insulating blankets. The high and low values for each 24-hour period of protection must be measured and recorded.
4. One acceptable method of checking temperature below the concrete surface is given in the Portland Cement Association (PCA) book entitled "Design and Control of Concrete Mixtures" latest edition. The method is indicated below and it should be noted that the thermometer should be capable of recording high and low values for a given 24-hour period.

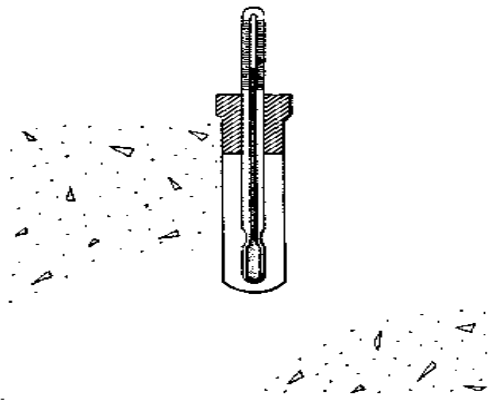

5. The exact method for surface and sub-surface concrete temperature monitoring shall be indicated in the contractor's cold weather concreting plan. The maximum permissible difference between the interior and surface temperature is 35 °F. Adjustments in protection method shall be implemented if the maximum permissible difference is exceeded.

F. Strength specimen handling

1. The Contractor is responsible for making, transporting, and curing all samples (beams or cylinders)
2. The Contractor is required to load the testing machine and dispose of the broken pieces.
3. Onsite, indoor curing facilities, meeting the requirements of ASTM C-31, shall be required for cold weather concreting operations.

4. Sampling for strength specimens shall be according to the Contract Special Provisions. Sampled concrete shall be transported to the indoor curing facilities for the casting of strength specimens.
5. The exact location and description of the curing facilities shall be indicated in the contractor's cold weather concreting plan.
6. The method of transporting concrete sampled from the grade to the curing facilities for casting shall be indicated in the contractor's cold weather concreting plan.

Steven J. Long, P.E.
Acting Chief Engineer

Supersedes Policy Memorandum 2001-1 dated January 1, 2001

APPENDIX A

Minimum exposure temperatures for concrete flatwork placed on the ground for concrete placed & surface temperature maintained at 50 F (10 C) for 3 days on ground at 35 F (2 C)

Slab thickness, in. (m)	Minimum ambient air temperature, deg F (deg C) allowable when insulation having these values of thermal resistance R, hr-ft ² -F/Btu (m ² -K/W), is used			
	R = 2 (0.35)	R = 4 (0.70)	R = 6 (1.06)	R = 8 (1.41)
Cement content = 300 lb/yd ² (178 kg/m ²)				
4 (0.10)	*	*	*	*
8 (0.20)	*	*	*	*
12 (0.31)	*	*	*	*
18 (0.46)	42 (6)	38 (3)	32 (0)	26 (-3)
24 (0.61)	37 (3)	25 (-4)	11 (-12)	-3 (-19)
30 (0.76)	31 (-1)	15 (-9)	-1 (-18)	-17 (-27)
36 (0.91)	31 (-1)	12 (-11)	-5 (-21)	-22 (-30)
Cement content = 400 lb/yd ² (237 kg/m ²)				
4 (0.10)	*	*	*	*
8 (0.20)	*	*	*	*
12 (0.31)	46 (8)	44 (7)	42 (6)	40 (4)
18 (0.46)	36 (2)	22 (-6)	8 (-13)	-6 (-21)
24 (0.61)	28 (-2)	9 (-13)	-10 (-23)	-29 (-34)
30 (0.76)	21 (-6)	0 (-18)	-21 (-29)	-42 (-41)
36 (0.91)	21 (-6)	-4 (-20)	-29 (-34)	-50 (-46)
Cement content = 500 lb/yd ² (296 kg/m ²)				
4 (0.10)	*	*	*	*
8 (0.20)	*	*	*	*
12 (0.31)	42 (6)	36 (2)	30 (-1)	24 (-4)
18 (0.46)	30 (-1)	12 (-11)	-6 (-21)	-22 (-30)
24 (0.61)	21 (-6)	-5 (-21)	-31 (-35)	-50 (-46)
30 (0.76)	16 (-9)	-10 (-23)	-42 (-41)	-74 (-59)
36 (0.91)	16 (-9)	-18 (-28)	-50 (-46)	#
Cement content = 600 lb/yd ² (356 kg/m ²)				
4 (0.10)	*	*	*	*
8 (0.20)	*	*	*	*
12 (0.31)	38 (3)	26 (-3)	14 (-10)	2 (-17)
18 (0.46)	24 (-4)	0 (-18)	-24 (-31)	-48 (-44)
24 (0.61)	14 (-10)	-16 (-27)	-46 (-43)	-82 (-63)
30 (0.76)	10 (-12)	-20 (-29)	-62 (-52)	#
36 (0.91)	7 (-14)	-30 (-34)	#	#

* > 50 F (10 C): additional heat required

<< -60 F (-51 C)

Minimum exposure temperatures for concrete flatwork placed on the ground for concrete placed & surface temperature maintained at 50 F (10 C) for 7 days on ground at 35 F (2 C)

Slab thickness, in. (m)	Minimum ambient air temperature, deg F (deg C) allowable when insulation having these values of thermal resistance R, hr-ft ² -F/Btu (m ² -K/W), is used			
	R = 2 (0.35)	R = 4 (0.70)	R = 6 (1.06)	R = 8 (1.41)
Cement content = 300 lb/yd ² (178 kg/m ²)				
4 (0.10)	*	*	*	*
8 (0.20)	*	*	*	*
12 (0.31)	*	*	*	*
18 (0.46)	46 (8)	42 (6)	36 (2)	30 (-1)
24 (0.61)	40 (4)	31 (-1)	22 (-6)	11 (-12)
30 (0.76)	35 (2)	22 (-6)	7 (-14)	-8 (-22)
36 (0.91)	31 (-1)	13 (-11)	-5 (-21)	-23 (-31)
Cement content = 400 lb/yd ² (237 kg/m ²)				
4 (0.10)	*	*	*	*
8 (0.20)	*	*	*	*
12 (0.31)	*	*	*	*
18 (0.46)	41 (5)	32 (0)	22 (-6)	12 (-11)
24 (0.61)	35 (2)	19 (-7)	-1 (-17)	-15 (-26)
30 (0.76)	28 (-2)	8 (-13)	-14 (-26)	-36 (-38)
36 (0.91)	23 (-5)	-4 (-20)	-29 (-34)	-54 (-48)
Cement content = 500 lb/yd ² (296 kg/m ²)				
4 (0.10)	*	*	*	*
8 (0.20)	*	*	*	*
12 (0.31)	48 (9)	44 (7)	40 (4)	36 (2)
18 (0.46)	36 (2)	22 (-6)	8 (-13)	-6 (-21)
24 (0.61)	28 (-2)	6 (-14)	-16 (-27)	-38 (-39)
30 (0.76)	22 (-6)	-7 (-22)	-36 (-38)	-64 (-53)
36 (0.91)	16 (-9)	-18 (-28)	-50 (-46)	#
Cement content = 600 lb/yd ² (356 kg/m ²)				
4 (0.10)	*	*	*	*
8 (0.20)	*	*	*	*
12 (0.31)	44 (7)	38 (3)	32 (0)	26 (-3)
18 (0.46)	31 (-1)	14 (-10)	-5 (-21)	-24 (-31)
24 (0.61)	22 (-6)	-5 (-21)	-32 (-36)	-61 (-52)
30 (0.76)	14 (-10)	-19 (-28)	-67 (-55)	#
36 (0.91)	7 (-14)	-30 (-34)	#	#

* > 50 F (10 C): additional heat required

< -60 F (-51 C)

Thermal Resistance of Various Insulating Materials

Insulating Material	Thermal resistance "R" for these thicknesses of material*	
	1 in., hr·ft ³ ·F / Btu	10 mm, m ³ ·K / W
Boards and slabs		
Expanded polyurethane (R-11 exp.)	6.25	0.438
Expanded polystyrene extruded (R-11 exp.)	5	0.347
Expanded polystyrene extruded, plain	4	0.277
Glass fiber, organic bonded	4	0.277
Expanded polystyrene, molded beads	3.57	0.247
Mineral fiber with resin binder	3.45	0.239
Mineral fiber board, wet felted	2.94	0.204
Sheathing, regular density	2.63	0.182
Cellular glass	2.63	0.182
Laminated paperboard	2	0.139
Particle board (low density)	1.85	0.128
Plywood	1.25	0.087
Blanket		
Mineral fiber, fibrous form processed from rock, slag, or glass	3.23	0.224
Loose fill		
Wood fiber, soft woods	3.33	0.231
Mineral fiber (rock, slag, or glass)	2.5	0.173
Perlite (expanded)	2.7	0.187
Vermiculite (exfoliated)	2.2	0.152
Sawdust or shavings	2.22	0.154

*Values from ASHRAE Handbook of Fundamentals, 1977,
American Society of Heating, Refrigerating, and Air-
Conditioning Engineers, New York.