

SECTION NO.	HIGHWAY	COUNTY	SHEETS
06-00082-02-PV	22	ST. CLAIR	4 OF 63
FHWA REG. NO. 7	ILLINOIS	ARA-5011(297)	
FEDERAL AID PROJECT		CONTRACT #97415	

TYPICAL SECTIONS

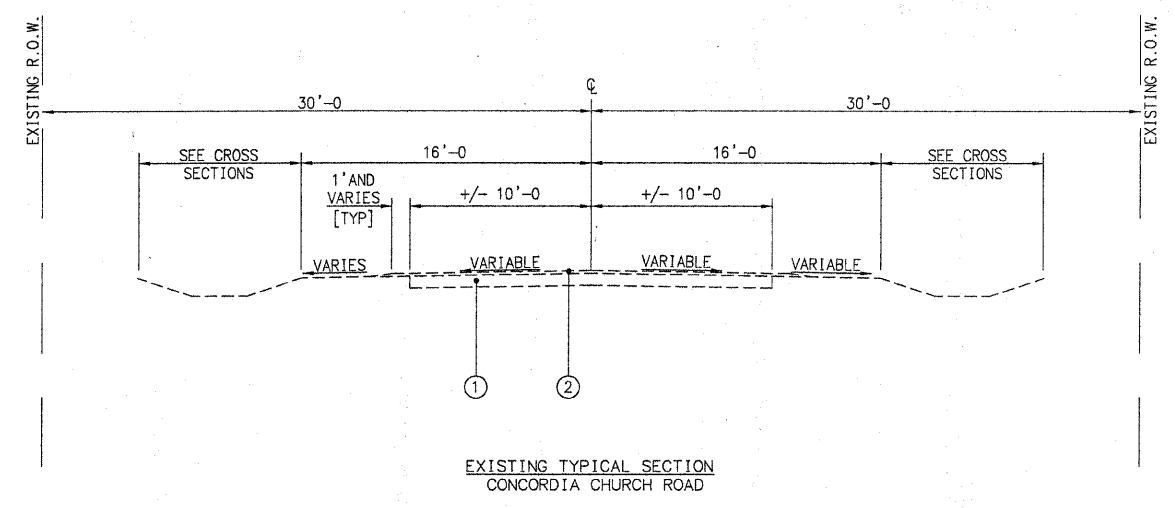

EXISTING TYPICAL SECTION
CONCORDIA CHURCH ROAD

LEGEND

- ① EXISTING AGGREGATE BASE (VARIABLE DEPTH 6-9")
- ② EXISTING BITUMINOUS SURFACE TREATMENT BUILD-UP

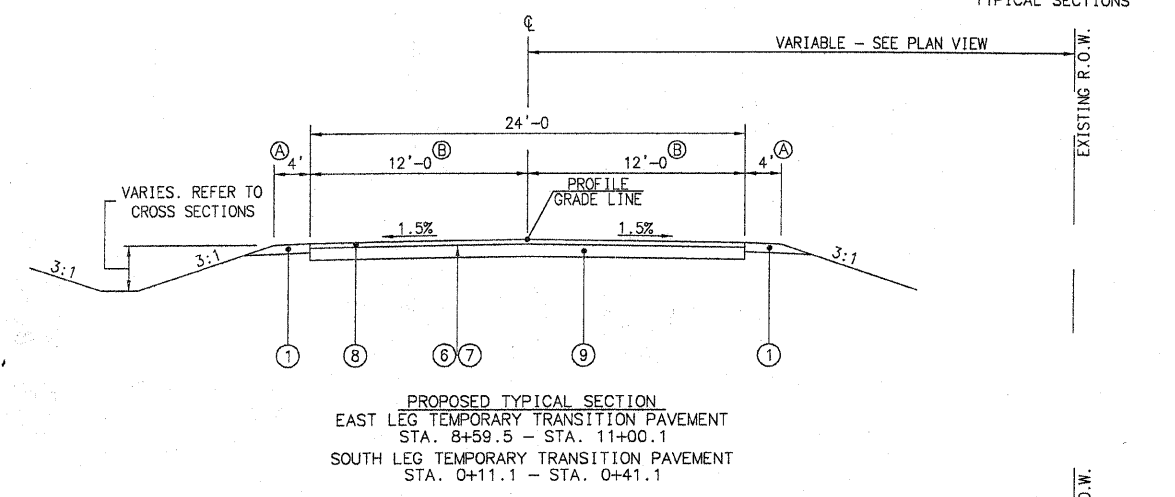

PROPOSED TYPICAL SECTION
EAST LEG TEMPORARY TRANSITION PAVEMENT
STA. 8+59.5 - STA. 11+00.1
SOUTH LEG TEMPORARY TRANSITION PAVEMENT
STA. 0+11.1 - STA. 0+41.1

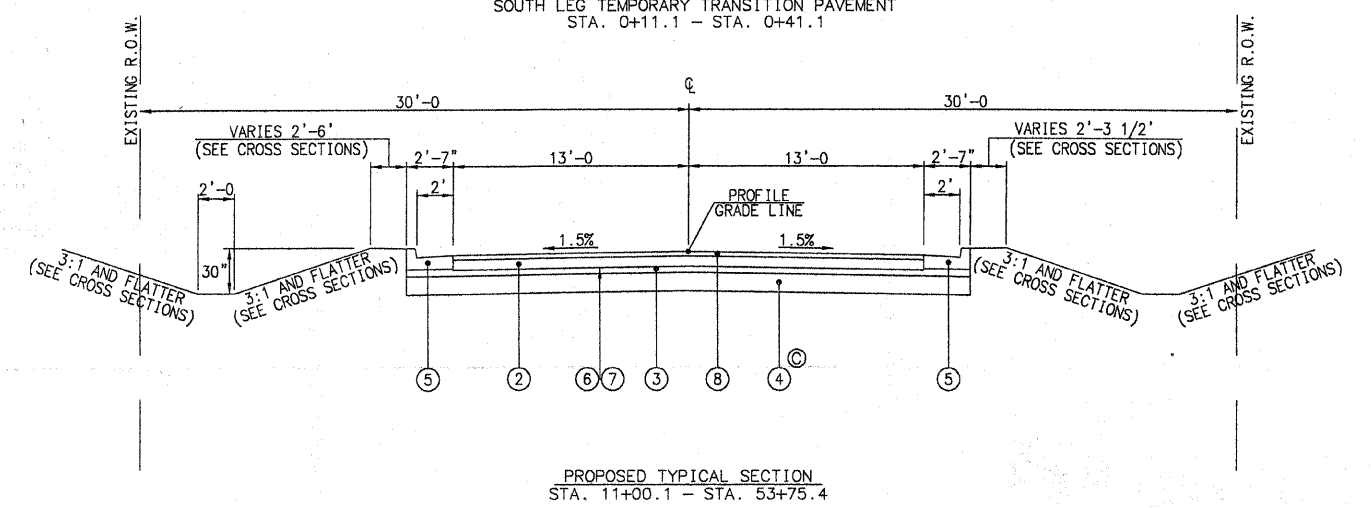

PROPOSED TYPICAL SECTION
STA. 11+00.1 - STA. 53+75.4

NOTE:

- (A) SHOULDER WIDTH ALONG EAST LEG TRANSITIONS FROM STA 8+59.5 TO STA 9+00 AND STA 10+85.1 TO STA 11+00.1
- (B) PAVEMENT WIDTH ALONG EAST LEG TRANSITIONS FROM STA 8+59.5 TO STA 9+00 AND STA 10+85.1 TO STA 11+00.1
- (C) CEMENT, 8% BY DRY WEIGHT, SHALL BE INCORPORATED INTO THE SOIL IN LIEU OF LIME BETWEEN STA.34+00 AND STA.38+00 DUE TO THE PRESENCE OF THE CLAYEY SILT IN THIS AREA.

LEGEND

- ① PROPOSED AGGREGATE SHOULDERS, TYPE A, 6"
- ② PROPOSED HOT-MIX BINDER COURSE, IL-19.0, N70, 6 3/4"
- ③ PROPOSED SUB-BASE GRANULAR MATERIAL, TYPE A, 4"
- ④ PROPOSED PROCESSING MODIFIED SOIL, 12"
- ⑤ PROPOSED COMBINATION CONCRETE CURB AND GUTTER, TYPE B-6.24
- ⑥ PROPOSED BITUMINOUS MATERIALS (PRIME COAT)
- ⑦ PROPOSED AGGREGATE (PRIME COAT)
- ⑧ PROPOSED HOT-MIX ASPHALT SURFACE COURSE, MIX 'C', N70, 3"
- ⑨ PROPOSED SUB-BASE GRANULAR MATERIAL, TYPE A, 8"

CONCORDIA CHURCH ROAD
STRUCTURAL DESIGN INFORMATION

HOT-MIX ASPHALT PAVEMENT (FULL-DEPTH) DESIGN
STRUCTURAL DESIGN TRAFFIC (2019): 2740
PV = 2,329 SU = 247 MU = 164
ROADWAY CLASSIFICATION: CLASS II
PERCENT OF S.D.T. IN DESIGN LANE:
P = 85% SU = 9% MU = 6%
TRAFFIC FACTOR: 0.74
SSR = POOR
RECOMMENDED PAVEMENT: DESIGN EAC = 490' (AC-20)
HOT-MIX ASPHALT SURFACE COURSE, MIX 'C', N70, 3"
HOT-MIX BINDER COURSE, IL-19.0, N70, 6 3/4"
4" SUB-BASE GRANULAR MATERIAL, TYPE A
12" PROCESSED MODIFIED SOIL

PLOT DATE: 11.24.2009

	INITIALS	DATE
DESIGNED	RGEORGEN	06/08
CHECKED	THOLDENER	12/08
DRAWN	RGEORGEN	06/08
CHECKED	THOLDENER	12/08
PREPARED BY ST. CLAIR COUNTY		
00092-02-PV_Typsecs.dwg		