

**BITUMINOUS SCHEDULE**

STATION TO STATION	WIDTH	LENGTH	PRIME COAT* GALLON .500 GAL/SQ YD	HMA BINDER CSE TON 112#/SQ YD/IN	HMA SURF CSE TON 112#/SQ YD/IN
254+75.00 - 256+42.38	24.63	167.38'	229		
257+41.63 - 259+00.00	24.63	158.37'	217		
254+75.00 - 256+42.38	22.44	167.38'		53	
257+41.63 - 259+00.00	22.44	158.37'		50	
254+75.00 - 256+42.38	22.13	167.38'			35
257+41.63 - 259+00.00	22.13	158.37'			33
<b>TOTAL</b>			<b>446</b>	<b>103</b>	<b>68</b>

\* PRIME COAT APPLIED TO AGGREGATE BASE

**EARTHWORK SUMMARY**

LOCATION	EXCAVATION	CHANNEL EXCAVATION	STRUCTURE EXCAVATION	FILL	WASTE (SHORTAGE)
	CU YD	CU YD	CU YD	CU YD	CU YD
RDWY 254+75.00 - 256+42.38	143			179	(72)
RDWY 257+41.63 - 259+00.00	113			47	38
CHANNEL STRUCTURE		741	95		
<b>TOTAL</b>	<b>256</b>	<b>741</b>	<b>95</b>	<b>226</b>	<b>(34)*</b>
<b>USE</b>	<b>255</b>	<b>740</b>	<b>95</b>	<b>-</b>	<b>(34)*</b>

\* To be obtained from suitable Channel Excavation (25% SHRINKAGE)

**GENERAL NOTES**

THE REMOVAL OF THE EXISTING OIL & CHIP SURFACE, GRAVEL, OR CRUSHED STONE BASE COURSE WHICH MAY BE NECESSARY FOR THE CONSTRUCTION OF THE NEW BRIDGE SHALL BE REMOVED AS EARTH EXCAVATION AND NO ADDITIONAL COMPENSATION WILL BE ALLOWED FOR ADDITIONAL LABOR OR EQUIPMENT REQUIRED.

ALL WASTE OR UNDESIRABLE MATERIAL AS IDENTIFIED BY THE ENGINEER SHALL BE DISPOSED OF OUTSIDE THE LIMITS OF THE RIGHT OF WAY AT THE CONTRACTOR'S EXPENSE.

ALL EXISTING PRIVATELY OWNED UTILITIES REQUIRING ADJUSTMENT WILL BE MADE BY THE UTILITY COMPANY INVOLVED. WHERE NO PROVISIONS HAVE BEEN MADE FOR ADJUSTMENTS ON THE PLANS, NO ADDITIONAL COMPENSATION WILL BE ALLOWED DUE TO DELAYS OR INCONVENIENCES CAUSED BY THE SAID UTILITY ADJUSTMENTS.

ALL EXISTING DRAINAGE STRUCTURES NOT BEING REMOVED BY THE CONTRACTOR THAT ARE DAMAGED DURING CONSTRUCTION SHALL BE REPLACED AT THE CONTRACTOR'S EXPENSE.

THE PROFILE GRADE ELEVATIONS SHOWN ON THE PLAN AND PROFILE SHEETS AND IN THE STATION CROSS SECTIONS ARE TO THE TOP OF THE FINISHED SURFACE.

ANY REFERENCE TO STANDARDS THROUGHOUT THE PLANS SHALL BE INTERPRETED TO BE THE LATEST STANDARDS OF THE ILLINOIS DEPARTMENT OF TRANSPORTATION

THE LOCATION OF UNDERGROUND UTILITIES SHOWN ON THE PLANS REPRESENTS THE BEST KNOWLEDGE OF THE COUNTY. IT SHALL BE THE CONTRACTOR'S RESPONSIBILITY TO VERIFY LOCATIONS OF UNDERGROUND INSTALLATIONS BEFORE STARTING CONSTRUCTION OPERATIONS. THE CONTRACTOR SHALL INDEMNIFY THE COUNTY, ITS OFFICERS AND EMPLOYEES AGAINST ALL CLAIMS DUE TO DAMAGE TO CORPORATE OR PRIVATE PROPERTY RESULTING FROM HIS CONSTRUCTION OPERATIONS AS DESCRIBED IN ARTICLES 107.20 AND 107.26 OF THE STANDARD SPECIFICATIONS.

THE CONTRACTOR MAY BE REQUIRED TO CONDUCT SOME OF HIS GRADING AND TRENCHING OPERATIONS AROUND TRANSMISSION POLES AND UNDER TRANSMISSION LINES. THE ADDED COST OF SO DOING SHALL BE INCLUDED IN THE COST OF EARTH EXCAVATION.

WHERE SECTION OR SUBSECTION MONUMENTS ARE ENCOUNTERED, THE ENGINEER SHALL BE NOTIFIED BEFORE SUCH MONUMENTS ARE REMOVED. THE CONTRACTOR SHALL PROTECT AND PRESERVE PROPERTY MARKERS UNTIL THE OWNER, AN AUTHORIZED SURVEYOR, OR AGENT, HAS WITNESSED OR OTHERWISE REFERENCED THEIR LOCATION.

ALL ELEVATIONS SHOWN REFER TO AN ASSUMED ELEVATION.

**TRAFFIC BARRIER TERMINAL, TYPE 1**

SIDE	STATION TO STATION	EACH
RT. & LT.	256+04.13 - 256+29.13	2
RT. & LT.	257+54.88 - 257+79.88	2
<b>TOTAL</b>		<b>4</b>

**AGGREGATE SHOULDERS**

STATION TO STATION	SIDE	WIDTH FT	AREA SQ YD	WEIGHT TON
254+75.00 - 256+42.38	LT	VAR.	132.1	27.2
254+75.00 - 256+42.38	RT	VAR.	132.1	27.2
257+41.63 - 259+00.00	LT	VAR.	127.9	26.4
257+41.63 - 259+00.00	RT	VAR.	127.9	26.4
<b>TOTAL</b>			<b>107.2</b>	<b>107</b>
<b>USE</b>			<b>107</b>	

**INLET AND PIPE PROTECTION**

STATION	SIDE	EACH
256+40	RT	1
256+45	LT	1
<b>TOTAL</b>		<b>2</b>

**TRAFFIC BARRIER TERMINAL, TYPE 5A**

SIDE	STATION TO STATION	EACH
RT. & LT.	256+29.13 - 256+42.38	2
RT. & LT.	257+41.63 - 256+54.88	2
<b>TOTAL</b>		<b>4</b>

**PERIMETER EROSION BARRIER**

STATION	SIDE	FOOT
254+75 - 256+45	LT	185
254+75 - 255+00	RT	30
257+40 - 259+00	RT	170
257+40 - 259+00	LT	170
<b>TOTAL</b>		<b>555</b>

**AGGREGATE BASE COURSE, TYPE A**

STATION - STATION	WIDTH (AVG.)	AREA (SQ YD)	WEIGHT (TON)
254+75.00 - 256+42.38	25.29	470	198
257+41.63 - 259+00.00	25.29	445	187
<b>TOTAL</b>		<b>915</b>	<b>385</b>

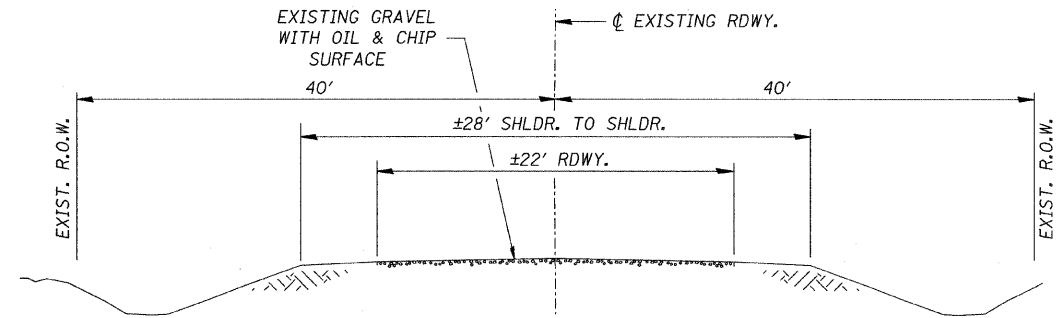

**EXISTING TYPICAL SECTION**

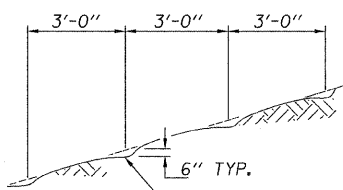

NOTE: ALL SLOPES 3:1 OR STEEPER AND GREATER THAN 5' IN HEIGHT SHALL BE CONTOUR PLOWED AS SHOWN IN DETAIL, COST SHALL BE INCLUDED WITH SEEDING, CLASS 2 (SPECIAL).

**DETAIL OF CONTOUR PLOWING**

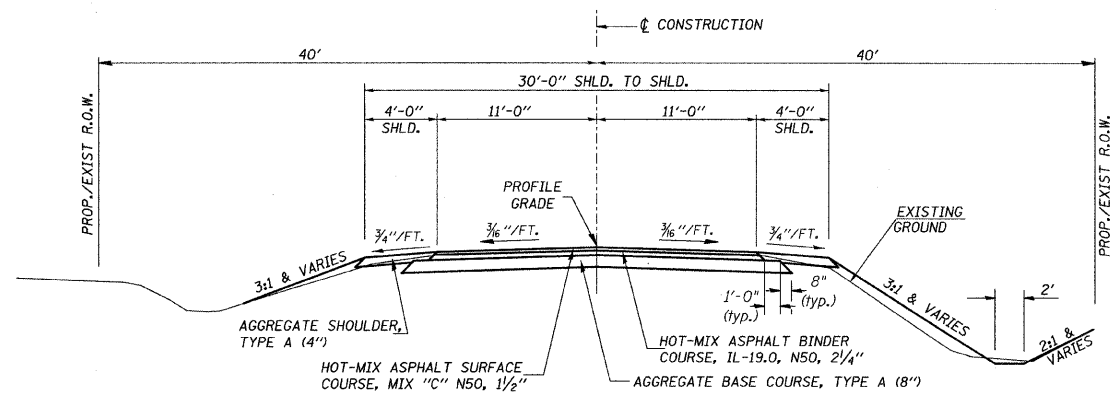

**PROPOSED TYPICAL SECTION**

STA. 254+75.00 TO STA. 256+42.38  
STA. 257+41.63 TO STA. 259+00.00  
EXCEPT TRANSITIONS  
  
BRIDGE OMISSION  
STA. 256+42.38 TO STA. 257+41.63

\* CONSTRUCT GUARDRAIL SHOULDER WIDENING IN ACCORDANCE WITH STD BLR 23

**STRUCTURAL DESIGN INFORMATION  
COUNTY HIGHWAY 12**

ROAD CLASSIFICATION: CLASS III  
STRUCTURAL DESIGN TRAFFIC:  
PV = 567 SU = 45 MU = 32  
PERCENT OF STRUCTURAL DESIGN TRAFFIC IN DESIGN LANE:  
P = 50% S = 50% M = 50%  
MINIMUM SUBGRADE SUPPORT RATING: FAIR  
FLEXIBLE PAVEMENT DESIGN: MINIMUM IFF = 0.105  
BITUMINOUS PAVEMENT THICKNESS: 3 3/4"  
AGGREGATE BASE COURSE, TYPE A: 8"

**BITUMINOUS CONCRETE  
MIXTURE REQUIREMENTS**

ITEM	ASPHALT GRADE	VOIDS
BINDER IL-19.0, N50	PG 64-22	4.0%
SURFACE (MIX 'C'), N50	PG 64-22	4.0%

**SUMMARY OF QUANTITIES**

CODE NO.	ITEM	UNIT	QUANTITY
20200100	EARTH EXCAVATION	CU YD	255
20300100	CHANNEL EXCAVATION	CU YD	740
25001000	SEEDING, CLASS 2 (SPECIAL)	ACRE	0.4
28000400	PERIMETER EROSION BARRIER	FOOT	555
28000500	INLET AND PIPE PROTECTION	EACH	2
28100209	STONE RIPRAP, CLASS A5	TON	765
28200200	FILTER FABRIC	SQ YD	755
35100100	AGGREGATE BASE COURSE, TYPE A	TON	385
40600100	BITUMINOUS MATERIALS (PRIME COAT)	GALLON	446
40603080	HOT-MIX ASPHALT BINDER COURSE, IL-19.0, N50	TON	103
40603310	HOT-MIX ASPHALT SURFACE COURSE, MIX 'C', N50	TON	68
48100100	AGGREGATE SHOULDERS, TYPE A	TON	107
50100100	REMOVAL OF EXISTING STRUCTURES	EACH	1
50104650	SLOPE WALL REMOVAL	SQ YD	660
50200100	STRUCTURE EXCAVATION	CU YD	95
50300225	CONCRETE STRUCTURES	CU YD	116.5
50300280	CONCRETE ENCASMENT	CU YD	8.1
50400305	PRECAST PRESTRESSED CONCRETE DECK BEAMS (17" DEPTH)	SQ FT	2,918
50800105	REINFORCEMENT BARS	POUND	10,170
50900205	STEEL RAILING, TYPE S-1	FOOT	199
51200957	FURNISHING METAL SHELL PILES 12"x0.25"	FOOT	1,281
51202305	DRIVING PILES	FOOT	1,281
51203200	TEST PILE METAL SHELLS	EACH	2
51500100	NAME PLATES	EACH	1
59300100	CONTROLLED LOW-STRENGTH MATERIAL	CU YD	14.2
63100075	TRAFFIC BARRIER TERMINAL, TYPE 5A	EACH	4
67100100	MOBILIZATION	L SUM	1
70103700	TRAFFIC CONTROL COMPLETE	L SUM	1
78201000	TERMINAL MARKER - DIRECT APPLIED	EACH	4
LR631020	TRAFFIC BARRIER TERMINAL, TYPE 1	EACH	4
X5020501	UNDERWATER STRUCTURE EXCAVATION PROTECTION, LOCATION 1	EACH	1
X5020502	UNDERWATER STRUCTURE EXCAVATION PROTECTION, LOCATION 2	EACH	1

① SEE SPECIAL PROVISIONS \* SPECIALTY ITEMS CONSTRUCTION CODE TYPE: X080-2A  
NOTE: PAVEMENT MARKING BY OTHERS.