

# PROJECTS WITHOUT RECONSTRUCTION

## S.M.A.R.T. IMPROVEMENTS (POLICY RESURFACING; BDE 53-4.03; 1/2")

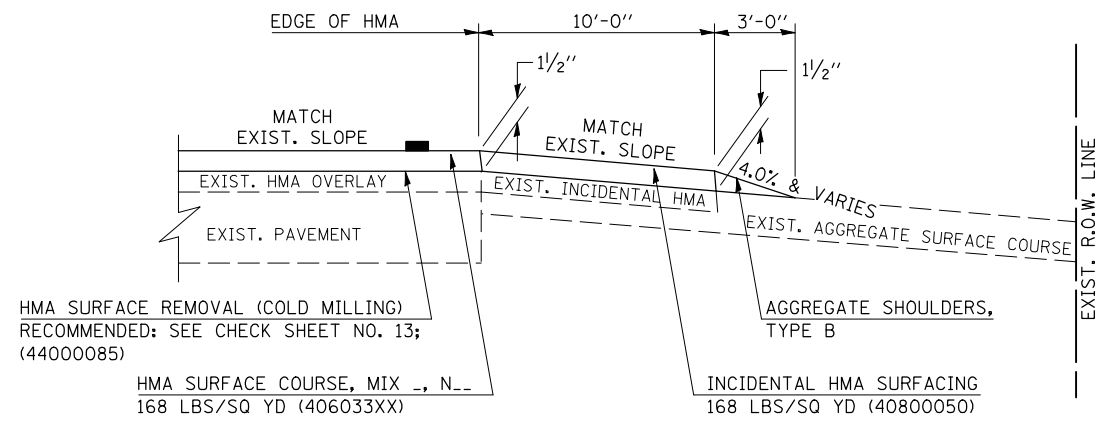

**EXISTING AGGREGATE ENTRANCE**

## "3P" OR "3R" IMPROVEMENTS (POLICY RESURFACING; BDE 53-4.02; 2 1/4" OR 2 1/2" ON BARE CONCRETE)

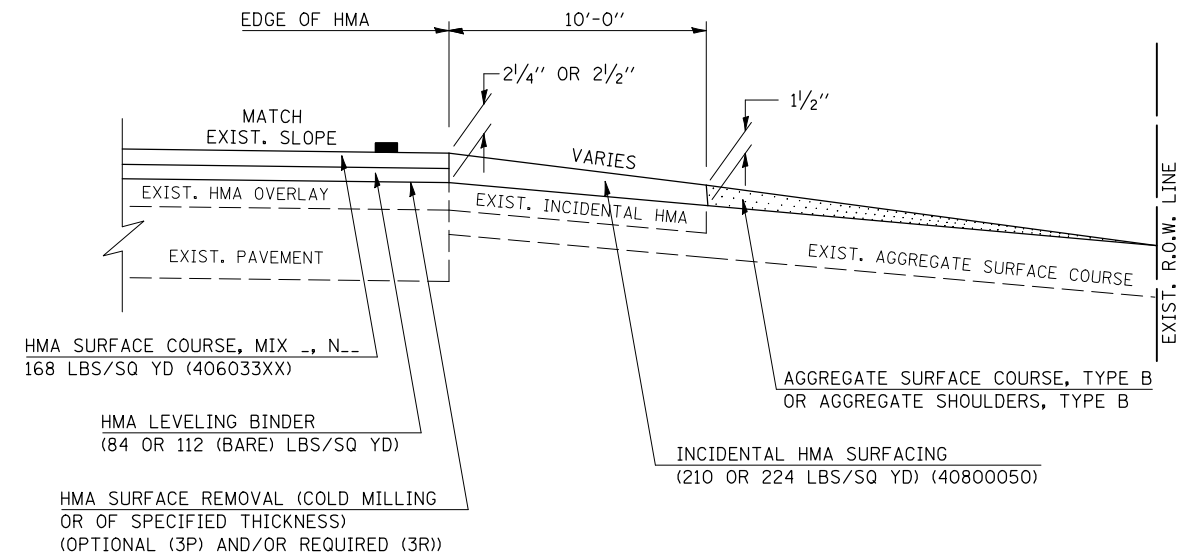

**EXISTING AGGREGATE ENTRANCE**

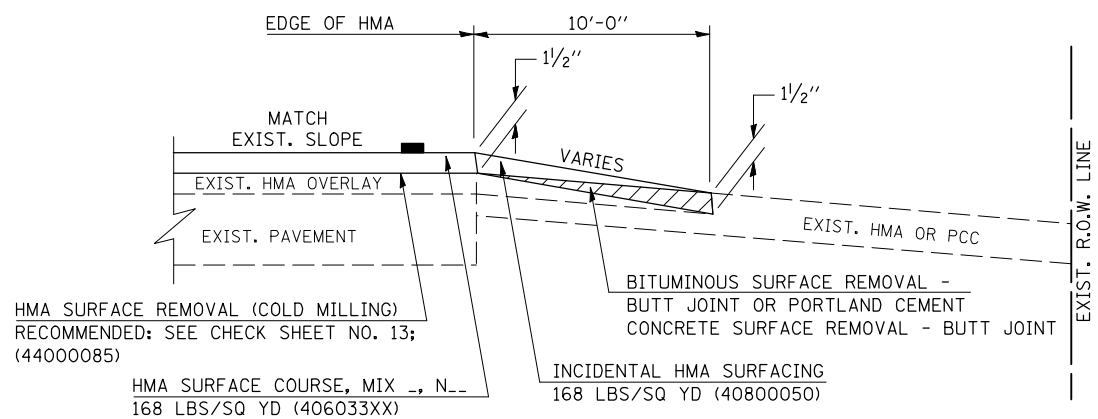

**EXISTING HMA OR PCC ENTRANCE**

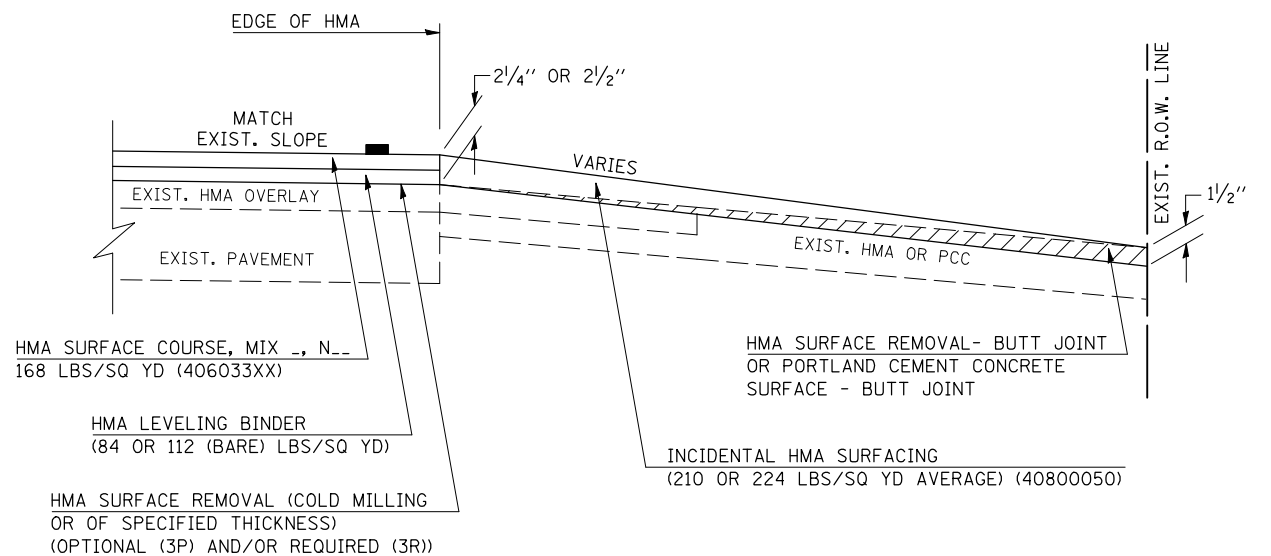

**EXISTING HMA OR PCC ENTRANCE**

Note: All dimensions are in INCHES  
(millimeters) unless otherwise shown.

### DISTRICT 5 DETAIL NO. 40800050C

FILE NAME =	USER NAME = dawsonkb	DESIGNED -	REVISED - 12/08/06 TJB
ct:\pw\work\PWIDOT\DAWSONKB\d0176650\0590875-54-63-District5Standards.dgn		DRAWN -	REVISED - 09/21/07 KAG
		CHECKED -	REVISED - 05/02/08 KJT
		DATE -	REVISED -

**STATE OF ILLINOIS  
DEPARTMENT OF TRANSPORTATION**

<b>PRIVATE AND COMMERCIAL ENTRANCES (NONCOMMERCIAL AND COMMERCIAL RURAL)</b>			
SCALE: NA	SHEET NO. 1 OF 2 SHEETS	STA.	TO STA.

F.A.I. RTE.	SECTION	COUNTY	TOTAL SHEETS	SHEET NO.
74	(10-6HB-5)BR	CHAMPAIGN	63	57
			CONTRACT NO. 90875	
FED. ROAD DIST. NO. ILLINOIS FED. AID PROJECT				