

Notes:
See sheet 11 of 20 for Sections B-B & C-C.
 a_{10} (E), a_{11} (E), and w_{10} (E) bar spacings measured parallel to \varnothing Rdwy.

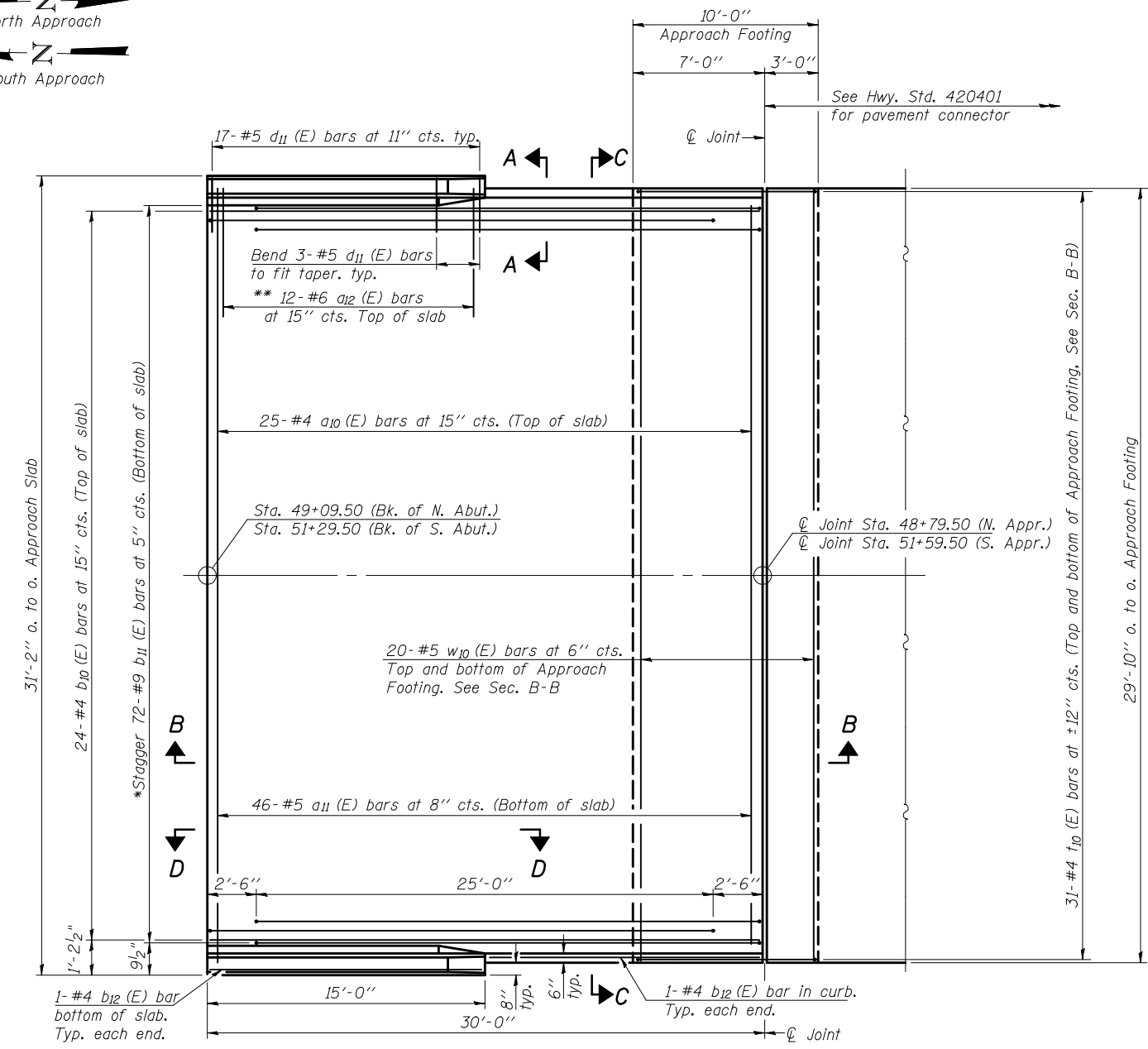

PLAN

* Tilt #9 b_{11} (E) bars as required to maintain clearance.
** Alternate with a_{10} (E) bars, typ. ea. parapet.

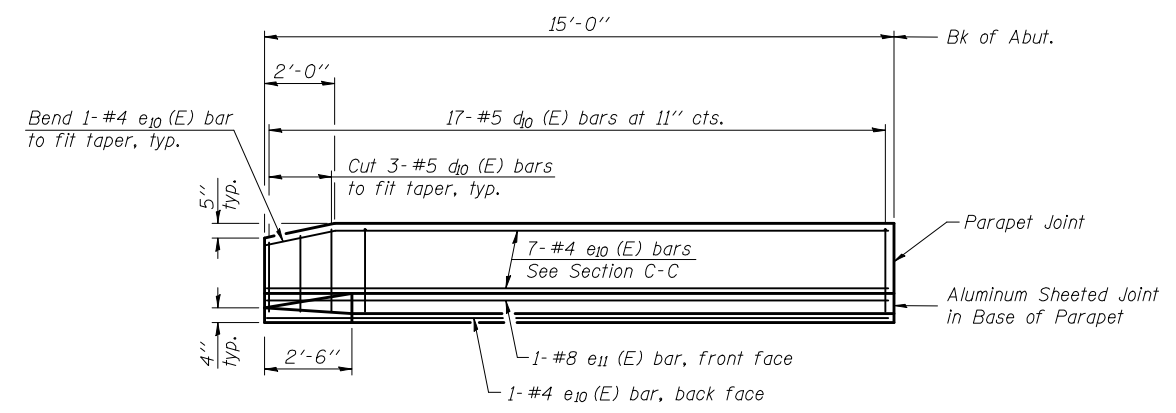

VIEW D-D

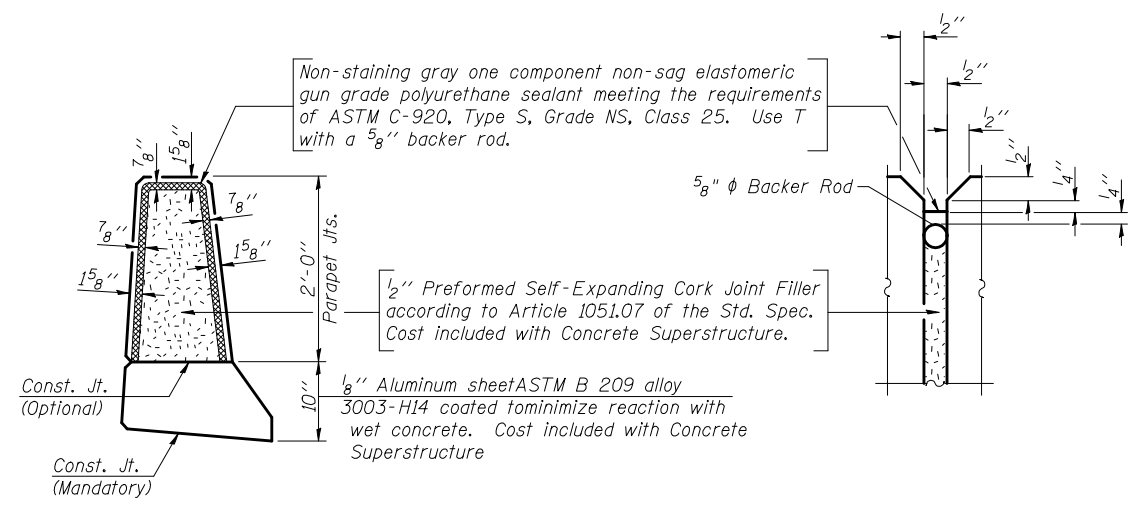

PARAPET JOINT DETAILS

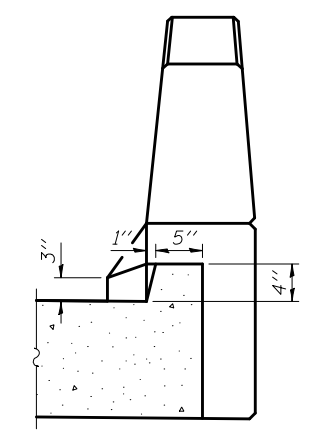

VIEW A-A

DESIGNED	CJC
CHECKED	MEB
DRAWN	UJ
CHECKED	MEB

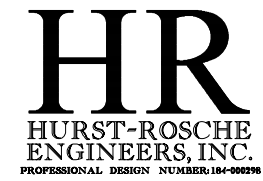

BRIDGE APPROACH SLAB DETAILS
STRUCTURE NO. 010-0285

SHEET NO. 10 20 SHEETS	F.A.I. RTE. 74	SECTION (10-6HB-5)BR	COUNTY CHAMPAIGN	TOTAL SHEETS 63	SHEET NO. 22
	SN 010-0285		CONTRACT NO. 90875		
FED. ROAD DIST. NO. 5 ILLINOIS FED. AID PROJECT					