

**STEEL POST CONSTRUCTION**

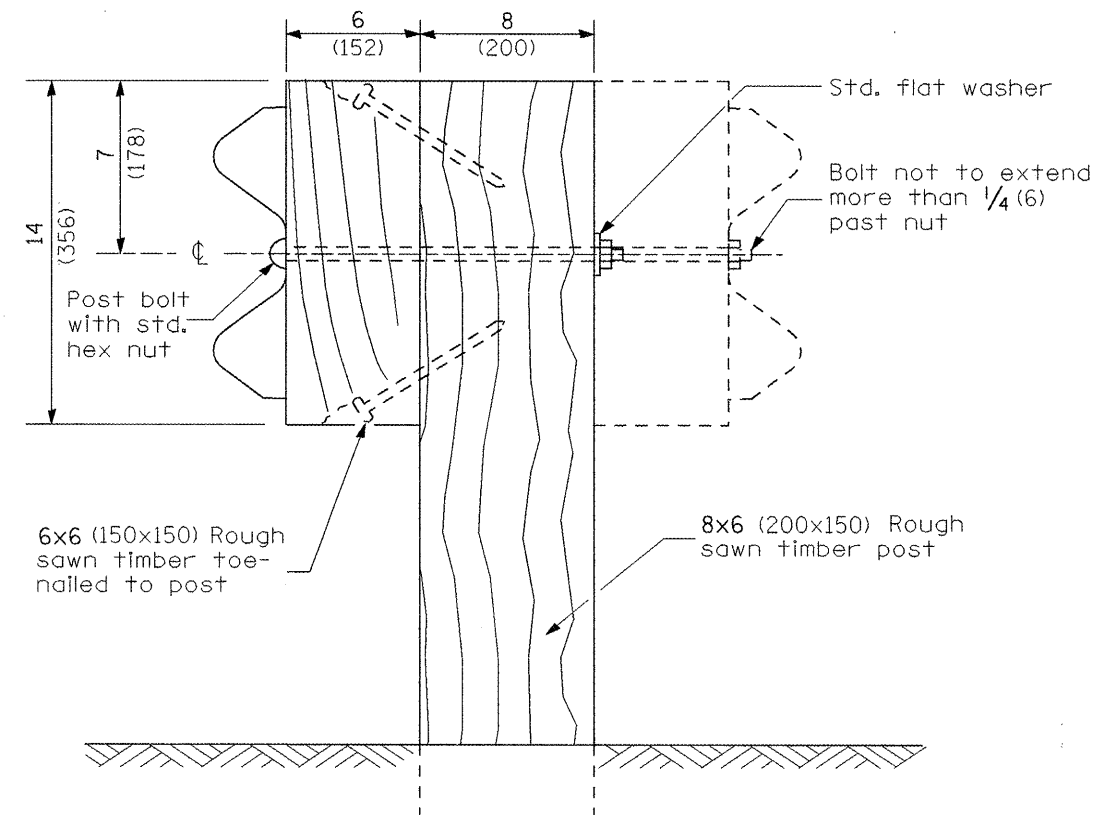

**WOOD POST CONSTRUCTION**

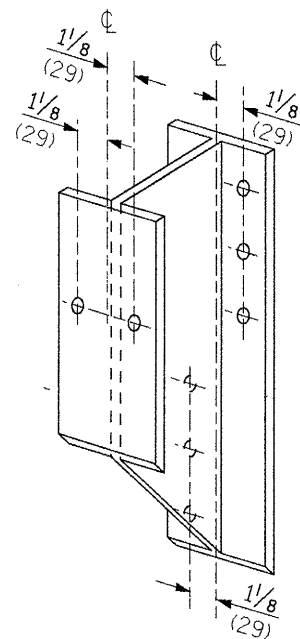

**STEEL BLOCK-OUT DETAIL**

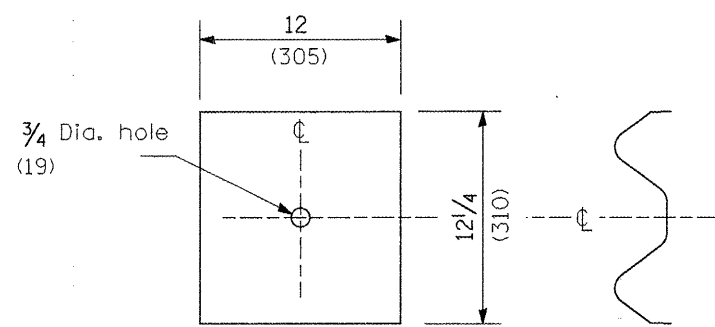

**NOTE**

Plate A shall be placed between rail element and block-out at non-splice mounting points only when steel block-outs are used.

**PLATE A**

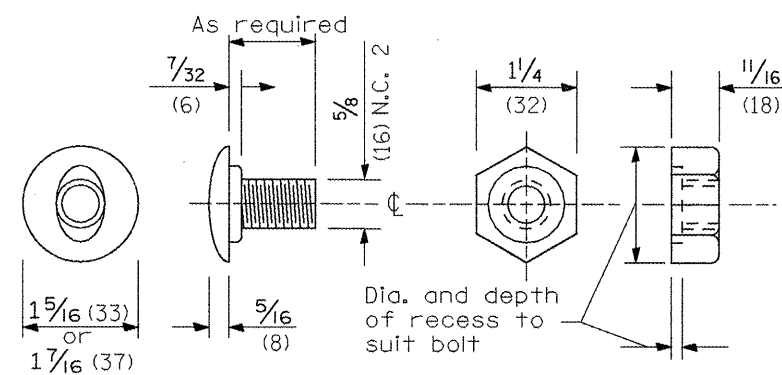

**POST OR SPLICE BOLT & NUT**

All dimensions are in Inches (millimeters) unless otherwise noted.