

LT. & RT. STA. 467+22.71 TO STA. 474+80.00
 LT. & RT. STA. 505+00.06 TO STA. 521+50.82(BK)=522+32.54(AH)

LEGEND - EXISTING

- (A) PCC PAVEMENT
- (B) BITUMINOUS OVERLAY
- (C) BITUMINOUS SHOULDER
- (D) AGGREGATE SHOULDER
- (E) COMB. CONC. CURB & GUTTER
TYPE M-6.12 OR CONC. GUTTER
- (F) CONC. MEDIAN SURFACE OR GRASS MEDIAN
- (G) WIDENING

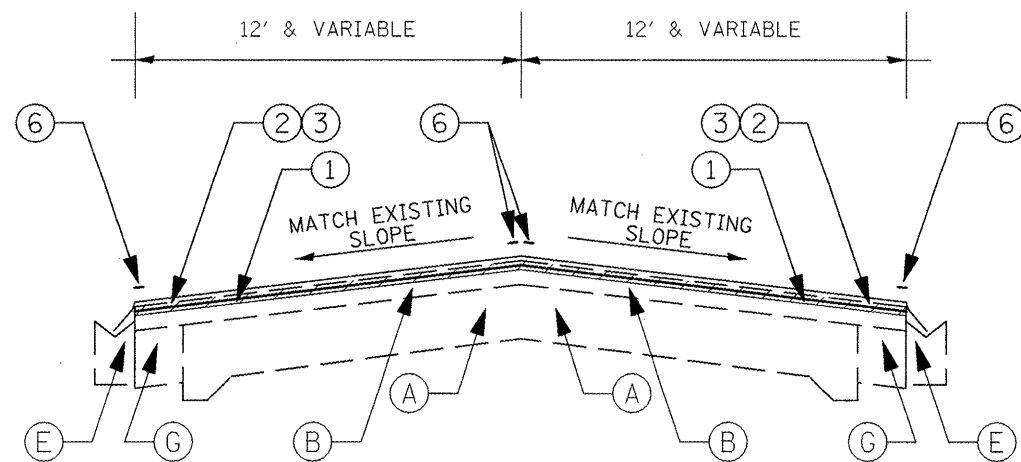

LT. & RT. STA. 474+80.00 TO STA. 493+00.00
 LT. & RT. STA. 504+00.00 TO STA. 505+00.06

LEGEND - PROPOSED

- ① HMA SURFACE REMOVAL, 1 1/2"
- ② HMA - LEVELING BINDER, 3/4"
- ③ HMA - SURFACE CSE., 1-1/2"
- ④ BITUMINOUS SHOULDER
- ⑤ AGGREGATE SHOULDER, TYPE B
- ⑥ URETHANE PAVEMENT MARKING

FILE NAME = D468472-shr-typical.dgn	USER NAME = taraja	DESIGNED -	REVISED -
		DRAWN -	REVISED -
	PLOT SCALE = 200.0000' / IN.	CHECKED -	REVISED -
	PLOT DATE = 12/18/2009	DATE -	REVISED -

**STATE OF ILLINOIS
DEPARTMENT OF TRANSPORTATION**

TYPICAL SECTIONS			
SCALE:	SHEET NO. 1 OF	SHEETS	STA. TO STA.

F.A.S. RTE.	SECTION	COUNTY	TOTAL SHEETS	SHEET NO.
2400	106RS-2; 107RS-4; 108RS-3	KNOX	29	9
CONTRACT NO. 68472				
ILLINOIS FED. AID PROJECT				