

LT. & RT. STA. 52+03.09 TO STA. 60+16.53

LEGEND - EXISTING

- (A) PCC PAVEMENT
- (B) BITUMINOUS OVERLAY
- (C) BITUMINOUS SHOULDER
- (D) AGGREGATE SHOULDER
- (E) COMB. CONC. CURB & GUTTER
TYPE M-6.12 OR CONC. GUTTER
- (F) CONC. MEDIAN SURFACE OR GRASS MEDIAN
- (G) WIDENING

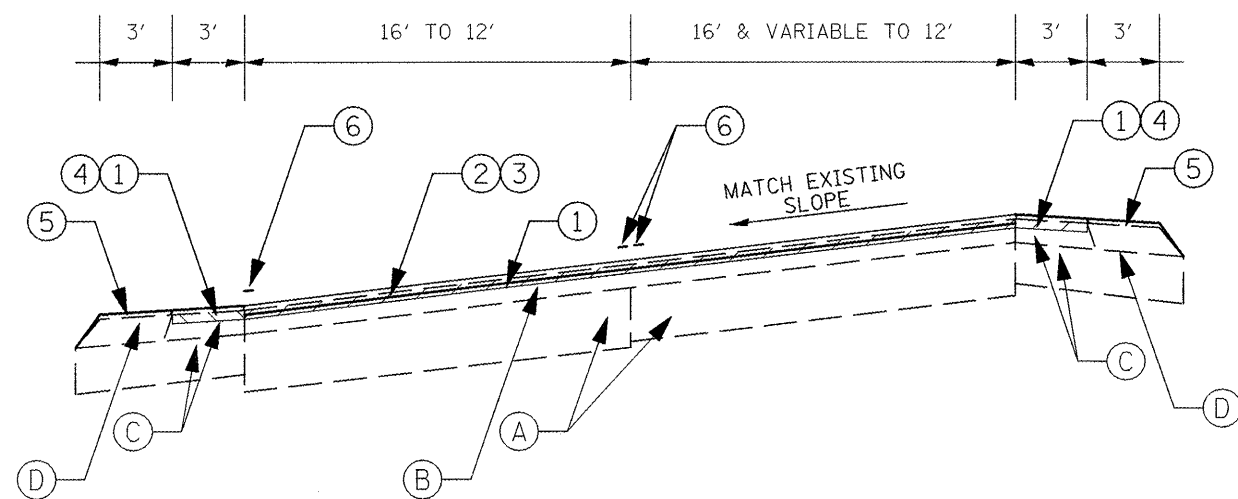

LT. & RT. STA. 60+16.53 TO STA. 83+43.00 (BK)
LT. & RT. STA. 39+41.00 (AH) TO STA. 42+44.96

LEGEND - PROPOSED

- (1) HMA SURFACE REMOVAL, 1 1/2"
- (2) HMA - LEVELING BINDER, 3/4"
- (3) HMA - SURFACE CSE., 1-1/2"
- (4) BITUMINOUS SHOULDER
- (5) AGGREGATE SHOULDER, TYPE B
- (6) URETHANE PAVEMENT MARKING

FILE NAME =
D468472-ah-typical.dgn

USER NAME = toraja

DESIGNED -

REVISED -

DRAWN -

REVISED -

PLOT SCALE = 200.0000' / IN.

PLOT DATE = 12/18/2009

CHECKED -

DATE -

REVISED -

REVISED -

STATE OF ILLINOIS
DEPARTMENT OF TRANSPORTATION

TYPICAL SECTIONS

SCALE: SHEET NO. 1 OF SHEETS STA. TO STA.

F.A.S. RTE.	SECTION	COUNTY	TOTAL SHEETS	SHEET NO.
2400	106RS-2; 107RS-4; 108RS-3	KNOX	29	7
CONTRACT NO. 68472				
ILLINOIS FED. AID PROJECT				