

STATE OF ILLINOIS
DEPARTMENT OF TRANSPORTATION

ROUTE NO.	SECTION	COUNTY	STATION	SHEET NO.	SHEET NO. 17 27 SHEETS
F.A.P. 301	1-HBR-2	WINNEBAGO	57	36	
FED. ROAD DIST. NO. 7		ILLINOIS	FED. AID PROJECT		

Contract #64D50

Notes:
Space reinforcement in cap to miss anchor bolts.
Pour steps monolithically with cap.

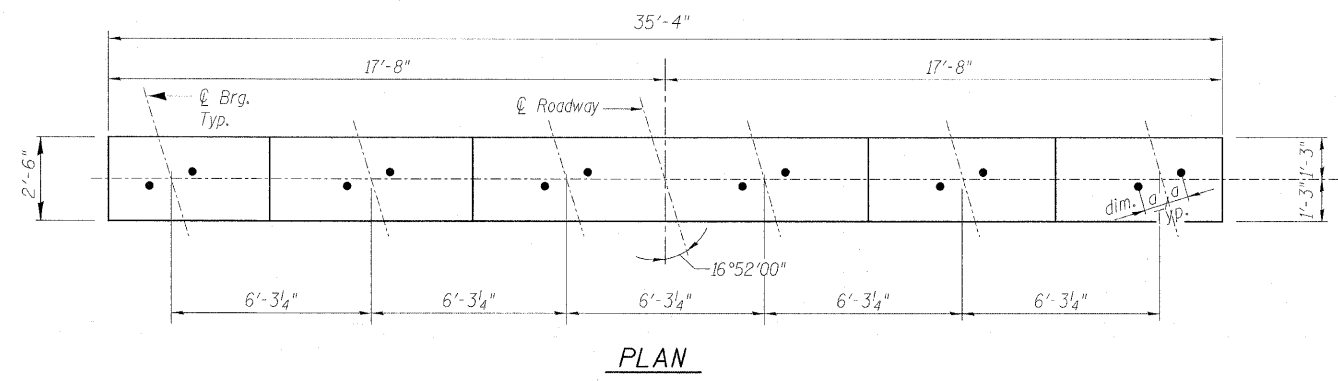

PLAN

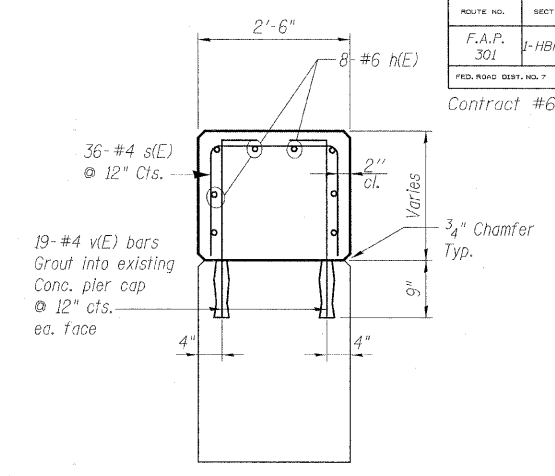

SECTION A-A

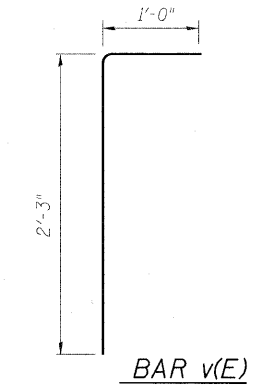

BAR v(E)

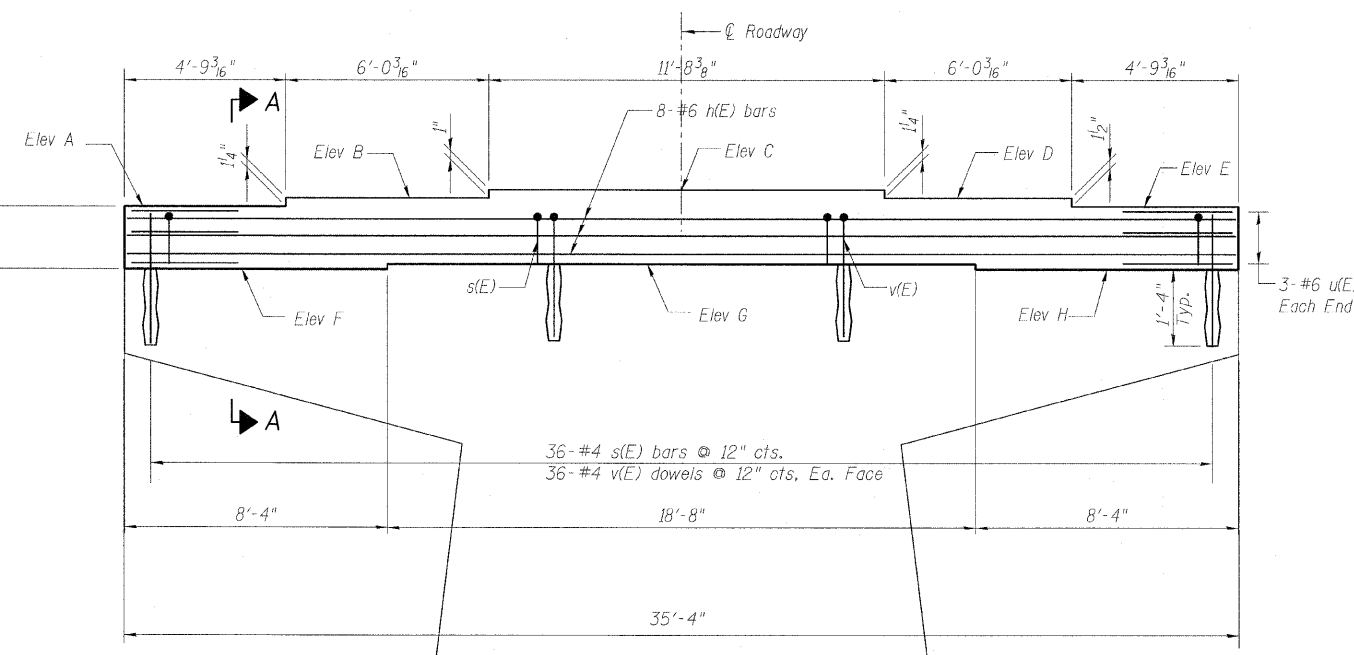

ELEVATION
(Looking North)

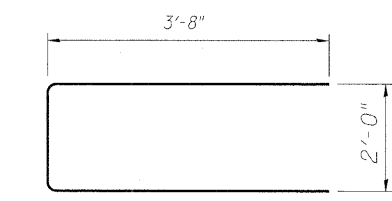

BAR u(E)

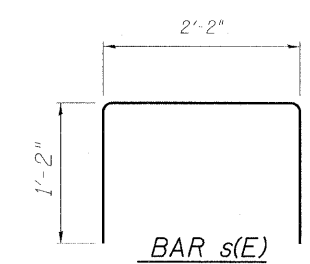

BAR s(E)

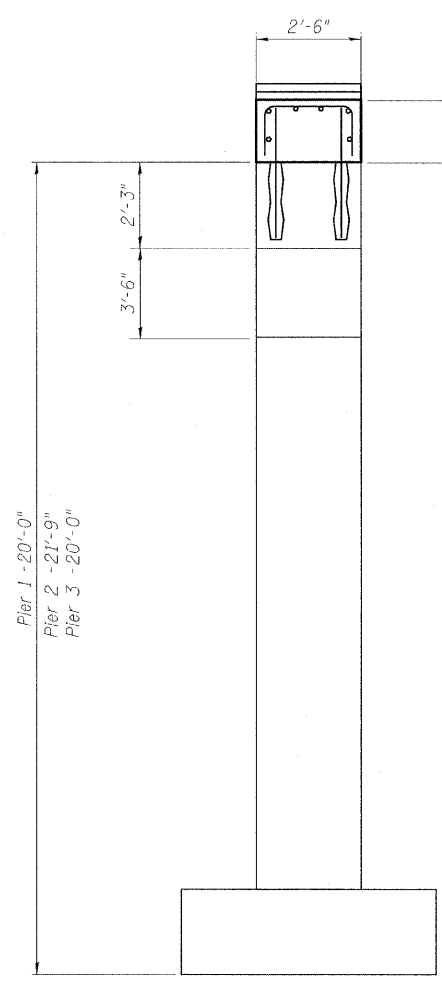

END VIEW

BILL OF MATERIAL (ONE PIER)

Bar	No.	Size	Length	Shape
h(E)	8	#6	35'-0"	—
s(E)	36	#4	4'-6"	□
u(E)	6	#6	9'-4"	—
v(E)	72	#4	3'-3"	—
Concrete Structures			Cu. Yd.	4.2
Reinforcement Bars, Epoxy Coated			Pound	770.0

	Pier 1	Pier 2	Pier 3
Elev. A	784.17	784.57	784.76
Elev. B	784.27	784.67	784.86
Elev. C	784.35	784.74	784.93
Elev. D	784.25	784.64	784.83
Elev. E	784.13	784.52	784.71
Elev. F	782.80	782.62	782.33
Elev. G	782.95	782.78	782.49
Elev. H	782.80	782.62	782.33
dim. a	1'-0 7/8"	7 1/2"	1'-0 7/8"

PIER DETAILS (1, 2 & 3)
MERIDIAN ROAD OVER US 20
F.A.P. 301 (US 20) - SEC. 1-HBR-2
WINNEBAGO COUNTY
STATION 100+00
STRUCTURE NO. 101-0096

DESIGNED	GUN / GAO
CHECKED	FCO
DRAWN	TCS / GUN
CHECKED	FCO

HOH HARRY O. HETTER-ASSOCIATES, INC.
55 East Jackson Blvd.
Suite 800
Chicago, IL 60604
312-346-8131
PROJECT NUMBER
2945

2:31:23 PM
 11/13/2009
 H:\Projects\2945\GIS\Structural\Meridian_Road\Construction\Issue\1010096-64D50-017-PIERDETAILS.dgn