

- STD. 701D
- CURB AND GUTTER GENERAL NOTES**
1. Thickness: "T" = thickness of the curb or gutter
  2. Depressed curbs: The top of a curb shall be depressed where it is constructed across a sidewalk, driveway, or where directed by the Director of Community Development. The transition from full height curb to depressed curb shall be at the rate of 3" per foot.
  3. Sub-grade: Improved sub-grade shall extend 1' outside of the back of curb.
  4. Sub-base: The sub-base shall consist of 4" of compacted crushed limestone.
  5. Concrete: Shall be a 6 bag mix, attaining a strength of not less than 3500 P.S.I. in 28 days.
  6. Contraction joints: Maximum of 25' intervals, grooved or sawcut a minimum of 1/8" wide, and a minimum of 2" deep. Sawing shall be completed within 24 hours of the pour.
  7. Expansion joints: 1" thick preformed joint filler with a single 5/4"x 18" epoxy coated smooth dowel bar, fitted with a pinch cap, installed 5' on either side of any structure within the curb line, at the PT and PC of a radius, and at the end of each concrete pour. Maximum spacing of 75'.
  8. Construction joints: Use whenever the placing of concrete is held up for 30 minutes or more. Construction joints shall be installed in the same manner as an expansion joint.
  9. Steel reinforcement: 2 continuous No. 4 bars centered in the curb over all trench crossings so that the bars extend 5' beyond the trench on all sides.
- | REVISIONS | VILLAGE OF ADDISON                  |
|-----------|-------------------------------------|
|           | APPROVED: 2/2/94                    |
|           |                                     |
|           | R. ESPEDIDO, P.E., VILLAGE ENGINEER |

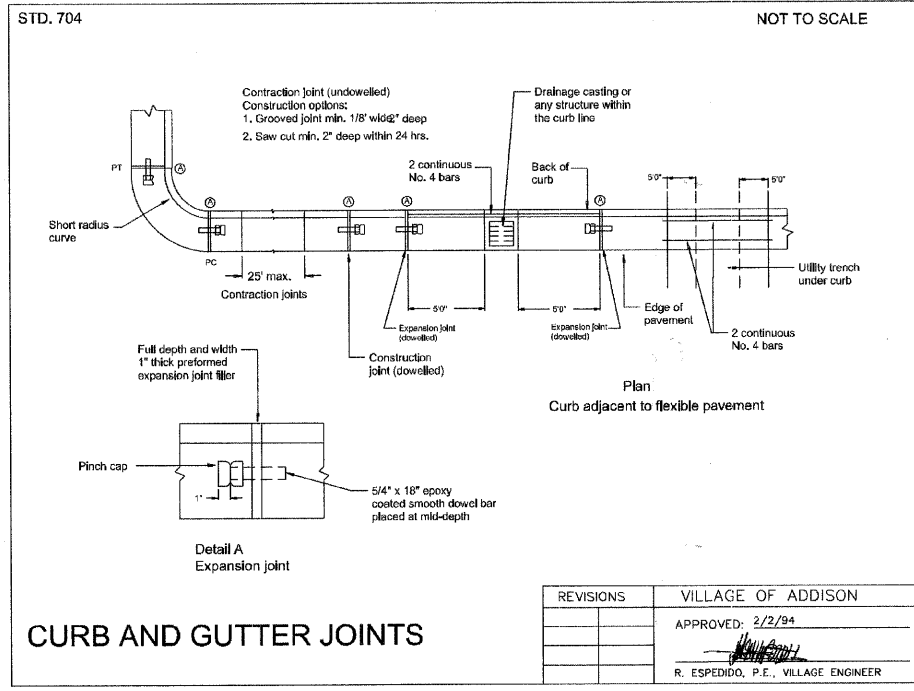

I:\ADDON\070142-ARMY TRAIL-MILL LAPP & WATER MAIN\CADD-SURVEY\DRAWINGS\DWG\070142-MH-DETS.DWG 57  
 Plotted: 1/17/2009 3:08 PM By: 23104G  
 Copyright © 2004 by Baxter & Woodman, Inc.  
 Date of Illinois License: 1/24/01 License No. 184-001121 - Expires 4-30-11

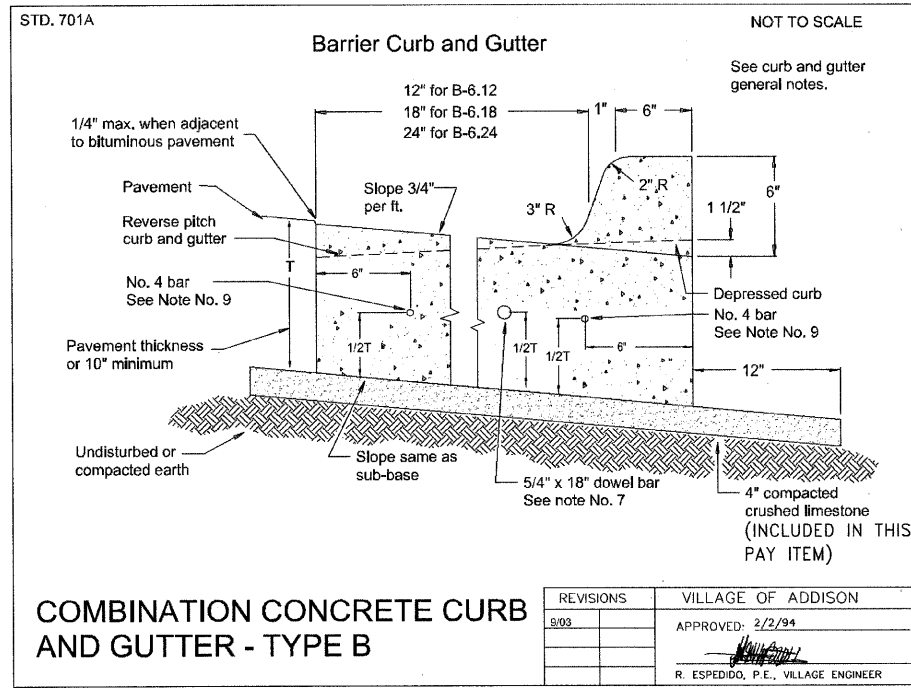

DESIGNED - JJS	REVISED - VILLAGE REVIEW 9-08-09
DRAWN - UKB	REVISED - VILLAGE REVIEW 11-05-09
CHECKED - SMV	REVISED - IDOT REVIEW 11-17-09
DATE - 8-19-09	REVISED -

**VILLAGE OF ADDISON, ILLINOIS**  
**MILL ROAD AND ARMY TRAIL BOULEVARD**  
**STP IMPROVEMENTS**

ADDISON DETAILS	
SCALE:	PROJECT NO: 070142 STA. TO STA.

*3884 ARMY TRAIL BLVD.		*2625 MILL ROAD		
F.A.U. RTE.	SECTION	COUNTY	TOTAL SHEETS	SHEET NO.
*	09-00098-00-RS	DuPage	69	57
C-91-056-10		CONTRACT NO. 63427		
FED. ROAD DIST. NO. 1		ILLINOIS FED. AID PROJECT M-9003 (474)		