

OPTION 1

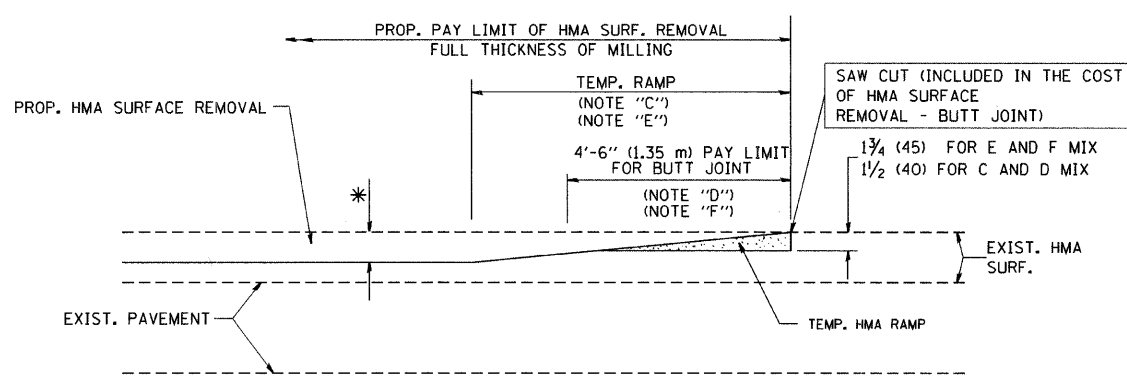

**HMA CONSTRUCTED TEMPORARY RAMP
(FOR BUTT JOINT AND HMA TAPER SEE DETAIL BELOW)**

OPTION 2

TYPICAL TEMPORARY RAMP

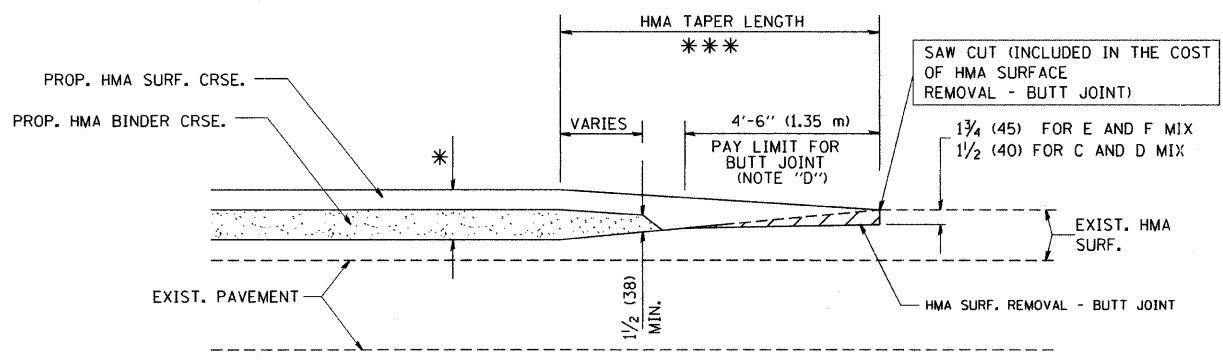

**BUTT JOINT AND
HMA TAPER**

**TYPICAL BUTT JOINT AND HMA TAPER
FOR MILLING AND RESURFACING**

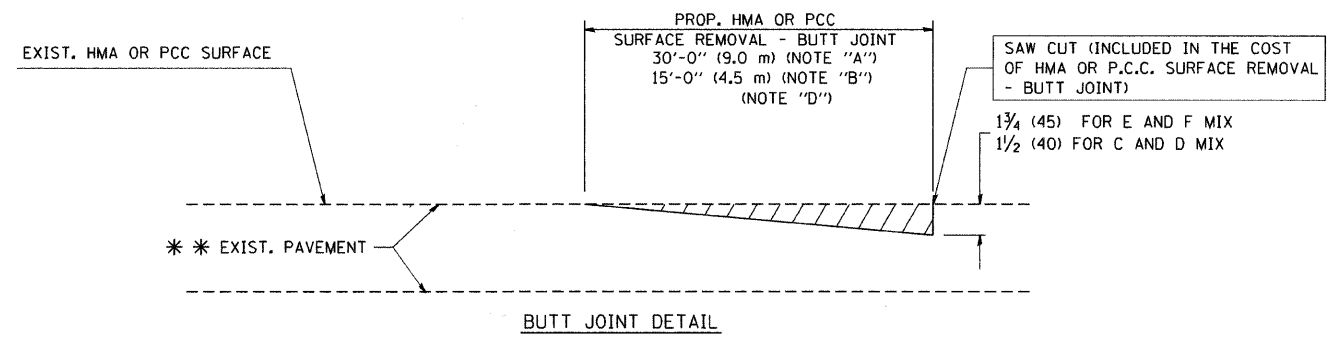

BUTT JOINT DETAIL

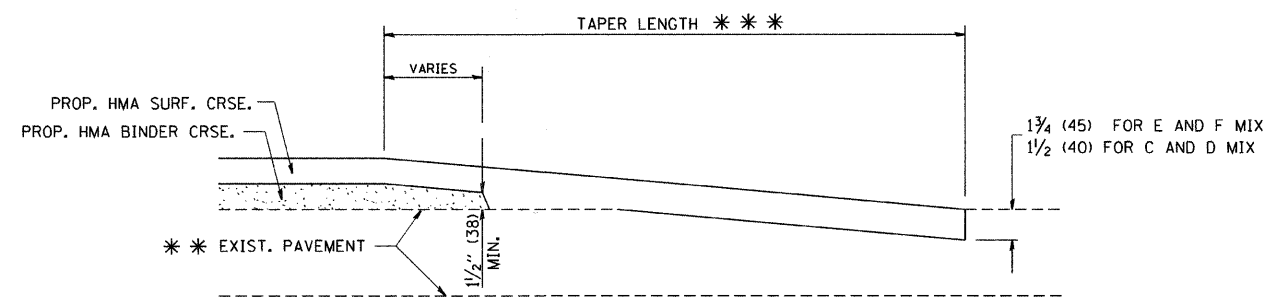

HMA TAPER DETAIL

**TYPICAL BUTT JOINT AND HMA TAPER
FOR RESURFACING ONLY**

*** PC CONCRETE, HMA OR HMA RESURFACED PAVEMENT.

NOTES

- A: MAINLINE ROADWAYS AND MAJOR SIDE ROADS.
- B: MINOR SIDE ROADS.
- C: THE TEMP. RAMP SHALL BE CONSTRUCTED IMMEDIATELY UPON REMOVAL OF THE EXISTING HMA SURFACE.
- D: THE BUTT JOINT SHALL BE CONSTRUCTED IMMEDIATELY PRIOR TO PLACING THE PROPOSED HMA COURSES.
- E: TAPER THE TEMP. RAMP AT A RATE OF 3'-0" (900 mm) PER 1 INCH (25 mm) OF MILLING THICKNESS.
- F: INSTALLATION AND REMOVAL OF THE 4'-6" (1.35 m) TEMP. RAMP IS INCLUDED IN COST OF HMA SURFACE REMOVAL - BUTT JOINT
- G: SEE ARTICLE 406.08 AND 406.14 OF THE STANDARD SPECIFICATIONS FOR "HMA AND/OR PCC SURFACE REMOVAL, BUTT JOINT".
- * SEE TYPICAL SECTIONS FOR MILLING THICKNESS.
- *** 20'-0" (6.1 m) PER 1 (25) RESURFACING (NOTE "A")
10'-0" (3.0 m) PER 1 (25) RESURFACING (NOTE "B")

BASIS OF PAYMENT:

THE BUTT JOINT WILL BE PAID FOR AT THE CONTRACT UNIT PRICE PER SQUARE YARD (SQUARE METER) FOR "HOT-MIX ASPHALT SURFACE REMOVAL - BUTT JOINT" OR FOR "PORTLAND CEMENT CONCRETE SURFACE REMOVAL - BUTT JOINT".

ALL DIMENSIONS ARE IN INCHES (MILLIMETERS) UNLESS OTHERWISE SHOWN.

| | | | | | | | | | | | | |
|--|------------------------|-----------------------------|-----------------------------|---|--|-------------------------|-----------------|----------------------------------|-------------|-----------------|--------------|--|
| FILE NAME = W:\diststd\22x34\bd32.dgn | USER NAME = geglentobt | DESIGNED - M. DE YONG | REVISED - R. SHAH 10-25-94 | STATE OF ILLINOIS DEPARTMENT OF TRANSPORTATION | BUTT JOINT AND HMA TAPER DETAILS | | F.A.P. RTE. 363 | SECTION 08-00370-00-SP | COUNTY KANE | TOTAL SHEETS 32 | SHEET NO. 23 | |
| PLOT SCALE = 50.0000' / IN. | CHECKED - | DRAWN - | REVISED - A. ABBAS 03-21-97 | | SCALE: NONE | SHEET NO. 1 OF 1 SHEETS | STA. TO STA. | BD400-05 BD32 CONTRACT NO. 63416 | | | | |
| PLOT DATE = 1/4/2008 | DATE - 06-13-90 | REVISOR - M. GOMEZ 04-06-01 | REVISED - R. BORO 01-01-07 | | FED. ROAD DIST. NO. 1 ILLINOIS FED. AID PROJECT HSIP-9003(056) | | | | | | | |
| | | | | | | | | | | | | |