

STATE OF ILLINOIS  
DEPARTMENT OF TRANSPORTATION

NORTH EDGE OF SHOULDER

Location	Station	Offset	Theoretical Grade Elevations
W. End of W. Aprr	643+91.44	-30.00	684.26
A1	644+01.44	-30.00	684.33
A2	644+11.44	-30.00	684.39
E. End of W. Aprr	644+21.44	-30.00	684.44

NORTH EDGE OF PAVEMENT

Location	Station	Offset	Theoretical Grade Elevations
W. End of W. Aprr	643+91.23	-27.00	684.32
A1	644+01.23	-27.00	684.39
A2	644+11.23	-27.00	684.45
E. End of W. Aprr	644+21.23	-27.00	684.51

W.B. P.G.

Location	Station	Offset	Theoretical Grade Elevations
W. End of W. Aprr	643+89.60	-3.00	684.75
A1	643+99.60	-3.00	684.82
A2	644+09.60	-3.00	684.88
E. End of W. Aprr	644+19.60	-3.00	684.94

☉ ROADWAY

Location	Station	Offset	Theoretical Grade Elevations
W. End of W. Aprr	643+89.40	0.00	684.80
A1	643+99.40	0.00	684.86
A2	644+09.40	0.00	684.93
E. End of W. Aprr	644+19.40	0.00	684.98

STAGE CONSTRUCTION LINE

Location	Station	Offset	Theoretical Grade Elevations
W. End of W. Aprr	643+89.37	0.50	684.79
A1	643+99.37	0.50	684.86
A2	644+09.37	0.50	684.92
E. End of W. Aprr	644+19.37	0.50	684.97

E.B. P.G.

Location	Station	Offset	Theoretical Grade Elevations
W. End of W. Aprr	643+89.20	3.00	684.75
A1	643+99.20	3.00	684.82
A2	644+09.20	3.00	684.88
E. End of W. Aprr	644+19.20	3.00	684.93

SOUTH EDGE OF PAVEMENT

Location	Station	Offset	Theoretical Grade Elevations
W. End of W. Aprr	643+87.57	27.00	684.30
A1	643+97.57	27.00	684.37
A2	644+07.57	27.00	684.43
E. End of W. Aprr	644+17.57	27.00	684.49

SOUTH EDGE OF SHOULDER

Location	Station	Offset	Theoretical Grade Elevations
W. End of W. Aprr	643+87.36	30.00	684.23
A1	643+97.36	30.00	684.30
A2	644+07.36	30.00	684.37
E. End of W. Aprr	644+17.36	30.00	684.42

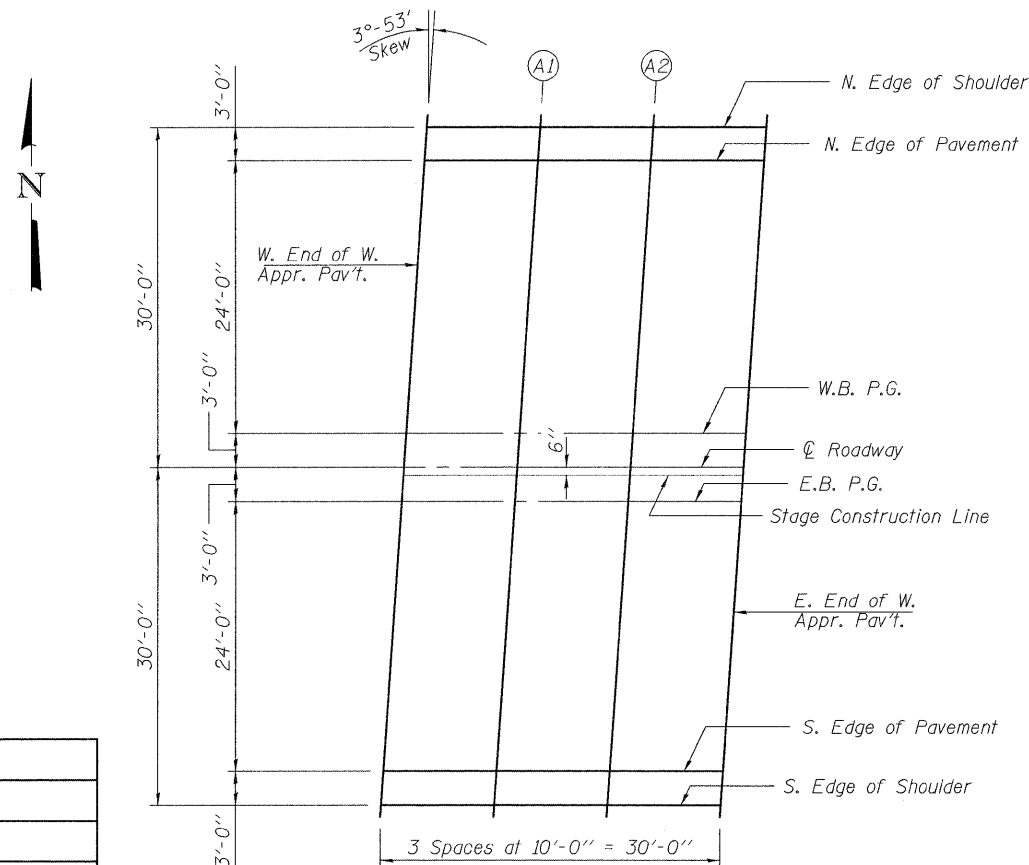

PLAN

DESIGNED	JMT
CHECKED	BLB
DRAWN	JMT
CHECKED	BLB

WEST APPROACH SLAB ELEVATIONS  
STRUCTURE NO. 022-0033

<b>rjngroup</b> Excellence through Ownership 200 West Front Street Wheaton, IL 60187	SHEET NO. 10	F.A.P. RTE.	SECTION	COUNTY	TOTAL SHEETS	SHEET NO.
	27 SHEETS	311	10HB-R	Du Page	53	26
			CONTRACT NO. 60B92			
FED. ROAD DIST. NO. _ ILLINOIS FED. AID PROJECT						

8/7/2009 K:\11225610\structures\final\_plans\Approach\_Slab.dgn