

* Verify before drilling holes in mounting tube and cross tubes.

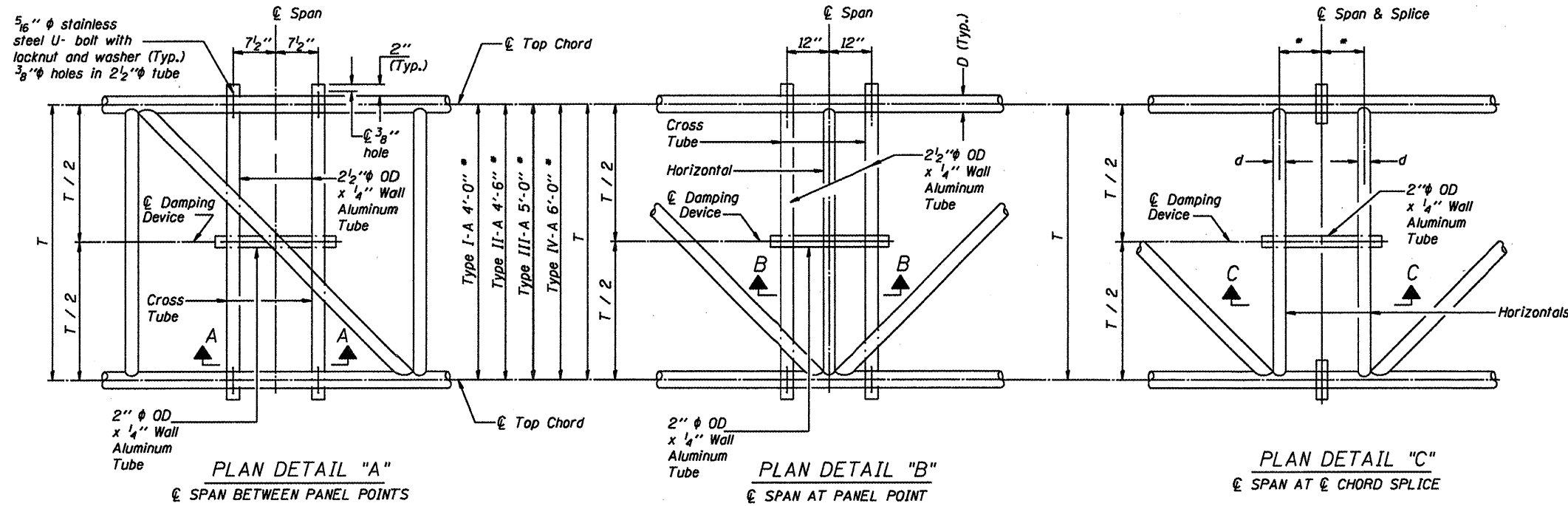

Note:
This detail applies to
Structure No. 3S0061080L062.5 only.

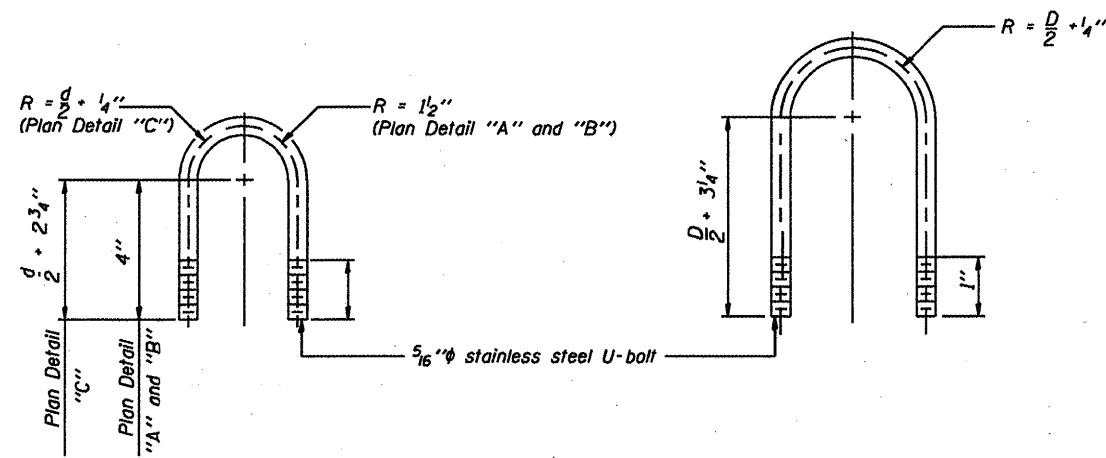
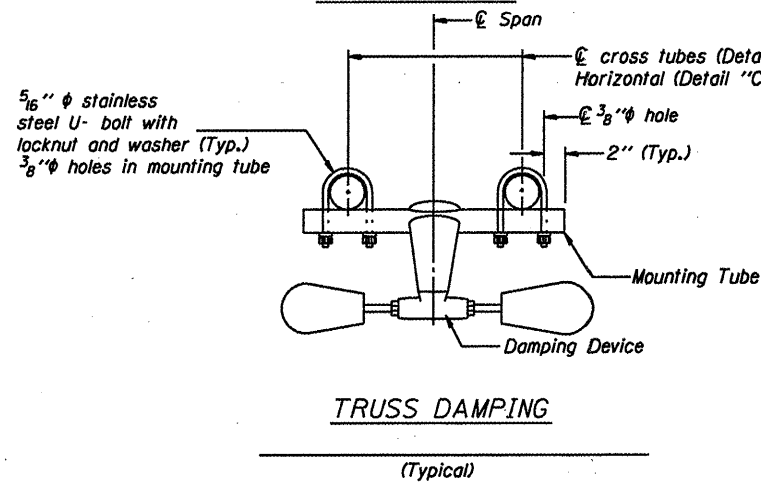
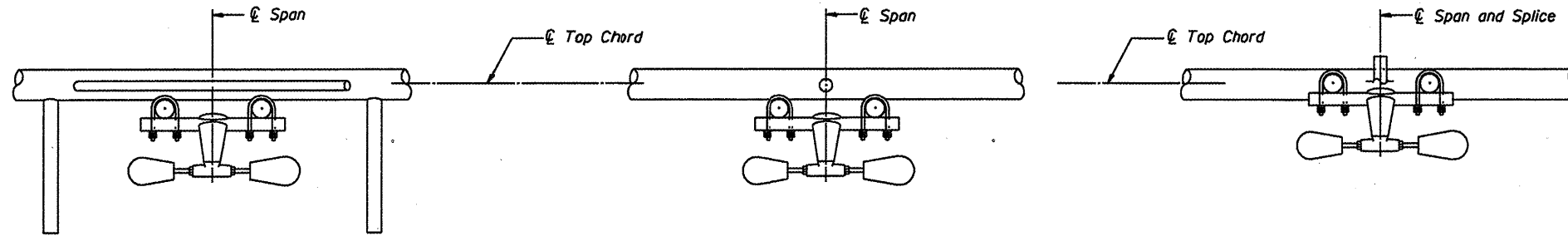

GENERAL NOTES

Damper: One damper per truss. (31 lbs. Stockbridge-Type Aluminum)
Materials: Aluminum tubes shall be ASTM B221 alloy 6061 temper T6
Fasteners: U-bolts shall be produced from ASTM A276 Type .304, 304L, 316 or 316L, Condition A, cold finish, or an equivalent material acceptable to the Engineer. All nuts shall be stainless steel conforming to ASTM A194, Grade B (AISI Type 304) or Grade BF (AISI Type 303). The nuts shall be "locknuts" with nylon or steel inserts and semifinished hexagonal heads equivalent to the finished hex series of the American National Standards. All washers shall be stainless steel conforming to ASTM A240, Type 302 or 304.

OVERHEAD SIGN STRUCTURE
DAMPING DEVICE

District 3
Sign Structure Replacement

DESIGNED -	20
CHECKED -	EXAMINED
DRAWN -	PASSED
CHECKED -	ENGINEER OF BRIDGES AND STRUCTURES