

- NOTES**
- Contractor may alternatively use standard aluminum drive-fit cap to close end. $\frac{1}{2}$ " ϕ drain hole in end plate/drive-fit cap. (Typ. at ends of all chords)
 - $5\frac{1}{2}$ " end dimension may vary by ± 1 " to provide uniform panel spacing (P).
 - Panel spacing (P) shall be uniform for entire truss and between 4'-0" and 5'-0" for Type I-A or 4'-0" and 5'-6" for Types II-A and III-A.
 - Vertical Diagonals in front and back face shall alternate.
 - Hidden lines show wind bracing alternates direction between planes of top and bottom chords.
 - All diagonals shall be detailed for minimum offset from the panel point based on the following: Offset shall be such as to provide a $\frac{3}{4}$ " minimum to $1\frac{1}{2}$ " maximum clearance between any diagonal and any horizontal or vertical member, and to provide clearance for U-bolt connections of signs or walkway brackets.

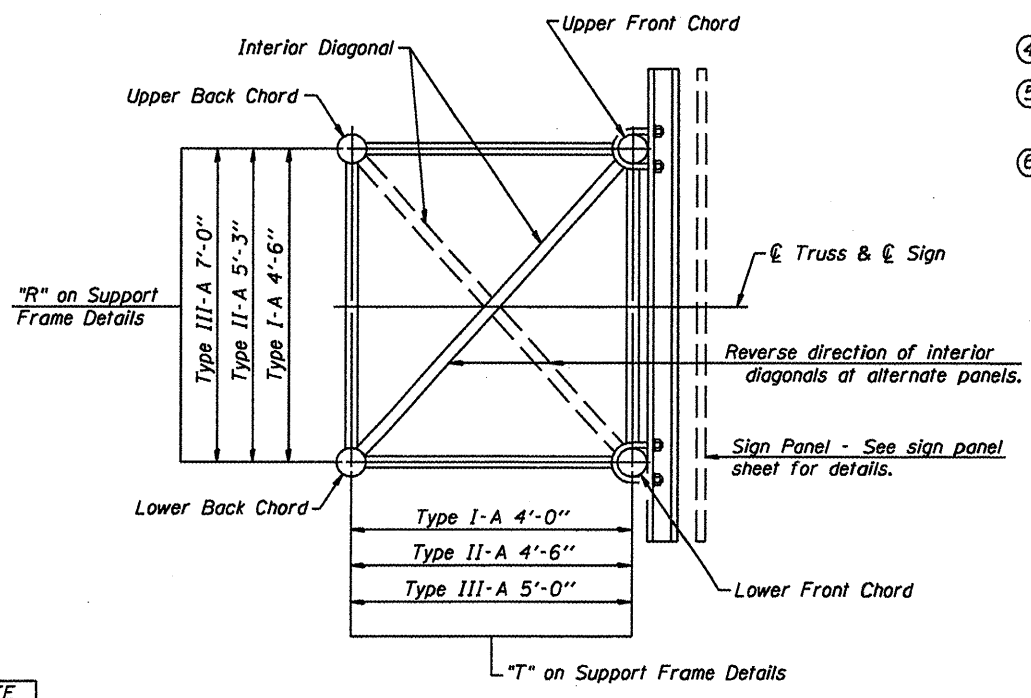
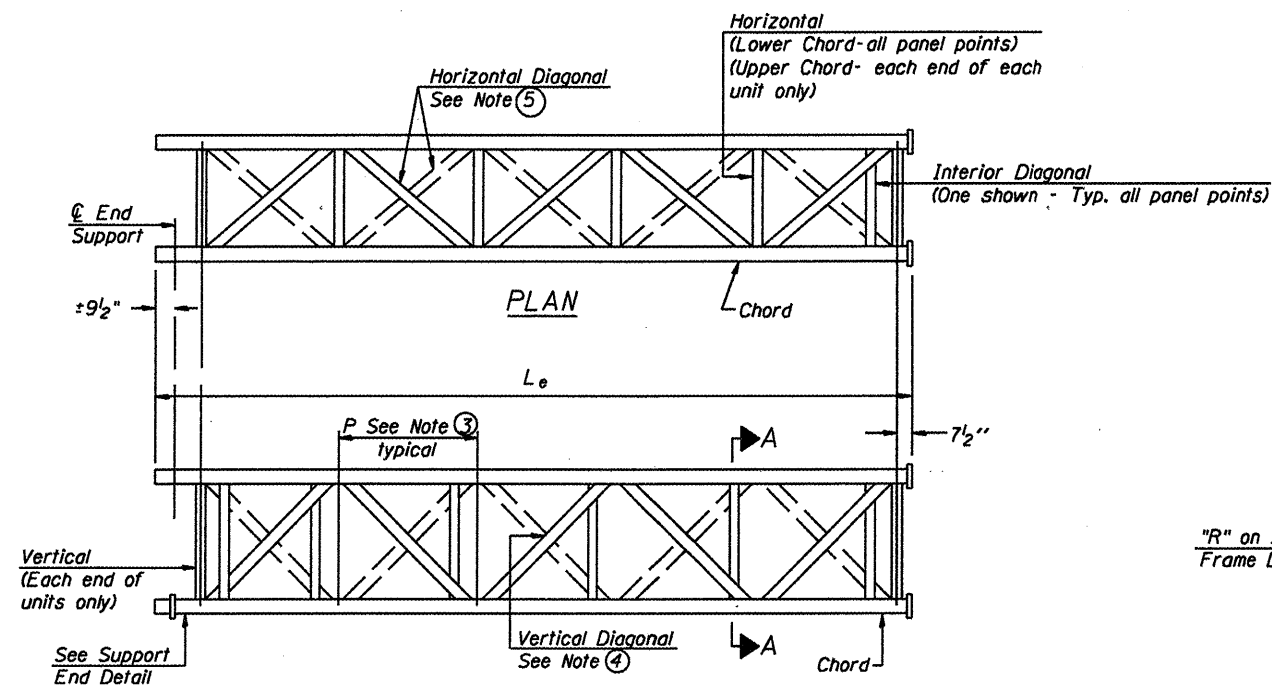

OVERHEAD SIGN STRUCTURES
ALUMINUM TRUSS DETAILS
FOR TRUSS TYPES I-A, II-A and III-A

District 3
Sign Structure Replacement

DESIGNED -	20
CHECKED -	EXAMINED
DRAWN -	PASSED
CHECKED -	

OS-A-2 5/16/08

NUMBER	REVISION	DATE