

STATE OF ILLINOIS
DEPARTMENT OF TRANSPORTATION
DIVISION OF HIGHWAYS
PROPOSED
HIGHWAY PLANS
FAS 732 (CH 12)
SECTION 01-00079-00-FP
MACOUPIN COUNTY
PROJECT HSIP-RS-0732 (150)
JOB NUMBER C-96-210-12

F.A.S. RTE.	SECTION	COUNTY	TOTAL SHEETS	SHEET NO.
732	01-00079-00-FP	MACOUPIN	141	1
FEDERAL AID PROJECT		ILLINOIS	CONTRACT NO. 93574	

FOR INDEX OF SHEETS AND APPLICABLE
 HIGHWAY STANDARDS SEE SHEET NO. 2

UTILITY CONTACTS:

UTILITY TYPE:

ELECTRIC
 AMEREN CIPS
 (217) 221-0850
 ATTN: RICK LAVIN

UTILITY TYPE:

ELECTRIC
 RURAL ELECTRIC CONVENIENCE COOPERATIVE
 (217) 438-6197
 ATTN: THOMAS JONES

UTILITY TYPE:

WATER
 GIRARD CITY OF
 (217) 627-3441
 ATTN: TODD NATALLA

UTILITY TYPE:

GAS
 ATMOS ENERGY
 (217) 836-6732
 ATTN: LES SMITH / CHUCK CONWAY

UTILITY TYPE:

FIBER
 LEVEL 3 COMMUNICATIONS
 (720) 888-7568
 ATTN: RICK MILLER

UTILITY TYPE:

WATER
 MILWOOD VILLAGE OF
 (217) 414-4931
 ATTN: TAMMY PAGE

UTILITY TYPE:

TELEPHONE
 FRONTIER
 (217) 243-0297
 ATTN: STEVE SAYLOR

UTILITY TYPE:

CABLE
 NEW WAVE COMMUNICATIONS
 (217) 287-7892
 ATTN: LARRY HARMON

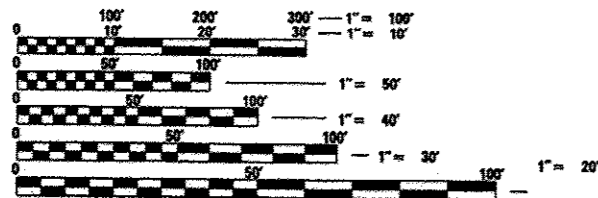
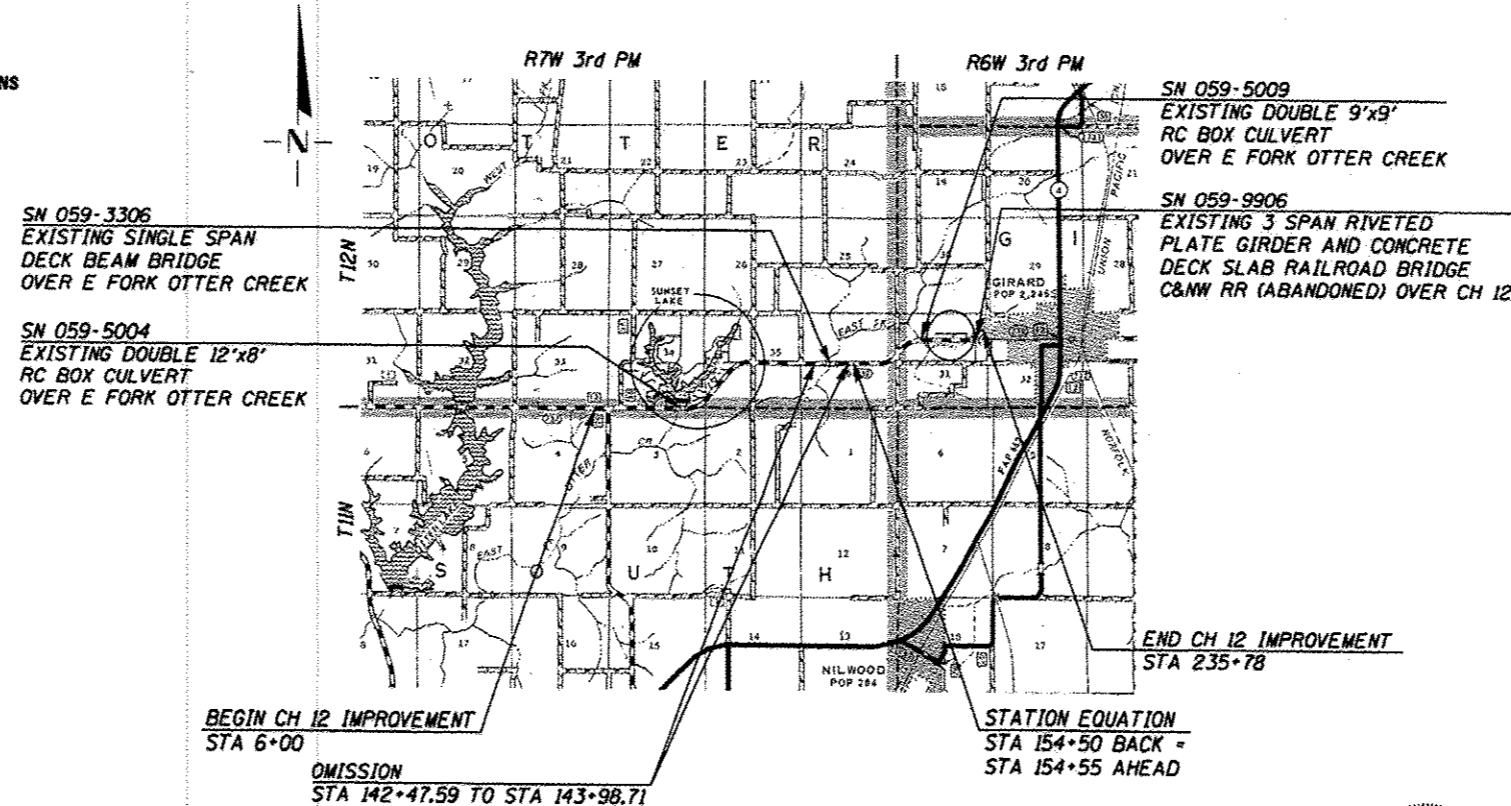
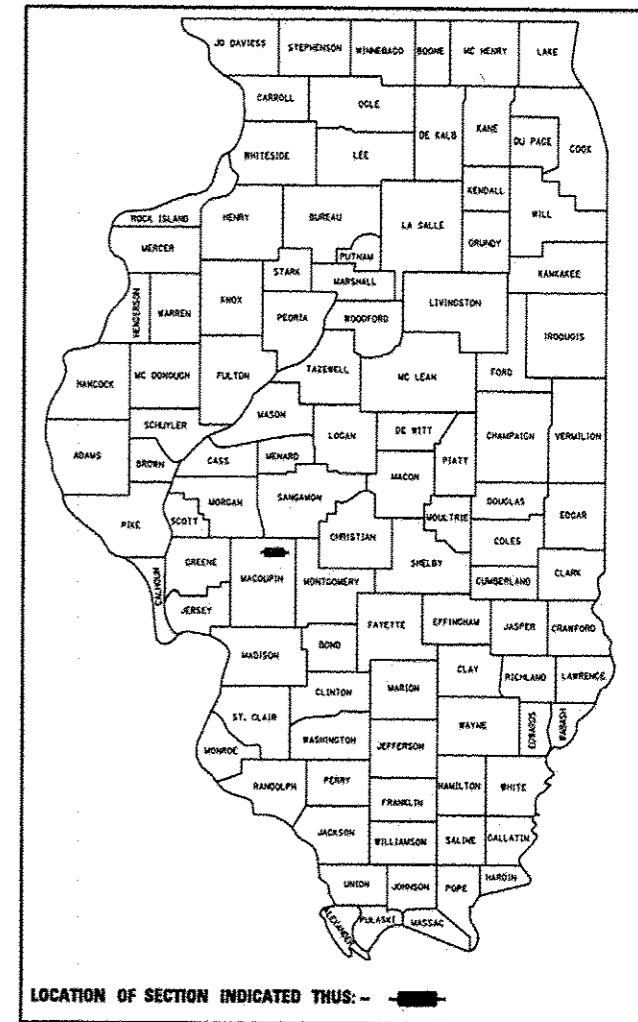

FULL SIZE PLANS HAVE BEEN PREPARED USING STANDARD
 ENGINEERING SCALES. REDUCED SIZED PLANS WILL NOT
 CONFORM TO STANDARD SCALES. IN MAKING MEASUREMENTS
 ON REDUCED PLANS, THE ABOVE SCALES MAY BE USED.

J.U.L.I.E.
 JOINT UTILITY LOCATION INFORMATION FOR EXCAVATION
 1-800-892-0123
 OR 811



CONTRACT NO. 93574

LAYOUT
 Gross Length of Section = 22,973.00 Feet = 4.350 Miles
 Net Length of Section = 22,821.88 Feet = 4.322 Miles



FUNCTIONAL CLASSIFICATION: COLLECTOR
 DESIGN SPEED 50 MPH
 CURRENT ADT = 2300 (2005)
 3R GUIDELINES



Michael D. Cummins 11/25/13
 ILLINOIS PROFESSIONAL NO. 43244
 (Expires 11/30/15)

STATE OF ILLINOIS
 DEPARTMENT OF TRANSPORTATION

APPROVED NOVEMBER 25 2013
Thomas A Reinhard
 MACOUPIN COUNTY ENGINEER

PASSED Jenene J. J. 2013
12-25-2013
 DISTRICT SIX ENGINEER OF
 LOCAL ROADS AND STREETS

PASSED December 12 2013
Ron A. Schaefer
 DISTRICT ENGINEER OF CONSTRUCTION

RELEASED FOR
 BID BASED ON
 LIMITED REVIEW December 12 2013
Debra D. Dethlefs
 DEPUTY DIRECTOR OF HIGHWAYS,
 REGION FOUR ENGINEER

**PRINTED BY THE AUTHORITY
 OF THE STATE OF ILLINOIS**

INDEX OF SHEETS

TITLE	SHEET NO
COVER SHEET	1
GENERAL NOTES, INDEX OF SHEETS, STANDARDS	2
SUMMARY OF QUANTITIES	3
TYPICAL CROSS SECTIONS	4-16
SCHEDULE OF QUANTITIES	17-22
SIGN LOCATION MAP	23
CH 12 PLAN & PROFILES	24-40
E LAKE DRIVE PLAN & PROFILE	41
HENRY ROAD PLAN & PROFILE	42
HENRY ROAD ALIGNMENT	43
HENRY ROAD INTERSECTION	44
CH 12 REMOVAL PLAN	45-52
HENRY ROAD REMOVAL PLAN	53
CH 12 EROSION CONTROL PLAN	54-61
HENRY ROAD EROSION CONTROL PLAN	62
GUARDRAIL PLAN	63
ENTRANCE DETAILS	64-65
TYPE A GUTTER (SPECIAL) (INLET, OUTLET & ENTRANCE)	66-68
PRECAST CONCRETE BOX CULVERT EXTENSION	69-70
CULVERT EXTENSION STA 48+38 SN 059-5004	71-72
CULVERT EXTENSION STA 188+27	73-74
CULVERT EXTENSION STA 198+85.5	75-76
CULVERT EXTENSION STA 224+92	77-78
CH 12 CROSS SECTIONS	79-121
E LAKE DRIVE CROSS SECTIONS	122
HENRY RD CROSS SECTIONS	123-133
CULVERT CROSS SECTIONS	134-141

LIST OF ILLINOIS DOT HIGHWAY STANDARDS

000001-06 STANDARD SYMBOLS, ABBREVIATIONS AND PATTERNS
001001-02 AREAS OF REINFORCEMENT BARS
001006 DECIMAL OF AN INCH AND OF A FOOT
280001-07 TEMPORARY EROSION CONTROL SYSTEMS
542301-03 PRECAST REINFORCED CONCRETE FLARED END SECTION
542306-02 PRECAST REINFORCED CONCRETE ELLIPTICAL FLARED END SECTION
542606-02 REINFORCED CONCRETE PIPE TEE
602401-03 MANHOLE, TYPE A
602406-06 MANHOLE, TYPE A, 6' (1.8 M) DIAMETER
602601-03 PRECAST REINFORCED CONCRETE FLAT SLAB TOP
602701-02 MANHOLE STEPS
604036-02 GRATE, TYPE 8
604101-01 MEDIAN INLET FOR 24" (600 MM) REINFORCED CONCRETE PIPE
630301-06 SHOULDER WIDENING FOR TYPE 1 (SPECIAL) GUARDRAIL TERMINALS
635006-03 REFLECTOR AND TERMINAL MARKER PLACEMENT
635011-02 REFLECTOR MARKER AND MOUNTING DETAILS
701006-05 OFF-ROAD OPERATIONS, 2L, 2W, 15' (4.5 M) TO 24" (600 MM) FROM PAVEMENT EDGE
701011-04 OFF-ROAD MOVING OPERATIONS, 2L, 2W, DAY ONLY
701311-03 LANE CLOSURE, 2L, 2W, MOVING OPERATIONS - DAY ONLY
701201-04 LANE CLOSURE, 2L, 2W, DAY ONLY, FOR SPEEDS > 45 MPH
701306-03 LANE CLOSURE, 2L, 2W, SLOW MOVING OPERATIONS DAY ONLY, FOR SPEEDS > 45 MPH
701901-03 TRAFFIC CONTROL DEVICES
780001-04 TYPICAL PAVEMENT MARKINGS
BLR 20-7 TRAFFIC BARRIER TERMINAL - TYPE 5R
BLR 21-9 TYPICAL APPLICATION OF TRAFFIC CONTROL DEVICES FOR CONSTRUCTION ON RURAL LOCAL HIGHWAYS
BLR 22-7 TYP. APPL. OF T.C.D. FOR RURAL LOC. HWYS. (2-LANE 2 WAY RURAL TRAFF.) (RD. CLOSED TO THRU TRAFF.)
BLR 26-3 STEEL PLATE BEAM GUARDRAIL 29 IN. (731 MM) HEIGHT

GENERAL NOTES

- THIS SECTION SHALL BE CONSTRUCTED IN ACCORDANCE WITH THE PLANS, THE STANDARD SPECIFICATIONS FOR ROAD AND BRIDGE CONSTRUCTION ADOPTED JANUARY 1, 2012, THE SUPPLEMENTAL SPECIFICATIONS AND RECURRING SPECIAL PROVISIONS, AND THE SPECIAL PROVISIONS INCLUDED IN THESE PLANS.
- ANY REFERENCE TO THE STANDARDS THROUGHOUT THE PLANS SHALL BE INTERPRETED TO BE THE EDITION, AS INDICATED BY THE SUB-NUMBER, LISTED IN THE INDEX OF SHEETS, OR THE COPY OF THE STANDARD INCLUDED IN THESE PLANS.
- THE THICKNESS OF HOT-MIX ASPHALT MIXTURES SHOWN ON THE PLANS IS THE NOMINAL THICKNESS. DEVIATIONS FROM THE NOMINAL THICKNESS WILL BE PERMITTED WHEN SUCH DEVIATIONS OCCUR DUE TO IRREGULARITIES IN THE EXISTING SURFACE OR BASE ON WHICH THE HOT-MIX ASPHALT MIXTURE IS PLACED.
- THE LOCATION OF THOSE BURIED AND ABOVE GROUND UTILITIES SHOWN ARE APPROXIMATE. THE CONTRACTOR SHALL BE RESPONSIBLE FOR PROTECTING UTILITY PROPERTY FROM CONSTRUCTION OPERATIONS AS OUTLINED IN ARTICLE 107.26 OF THE STANDARD SPECIFICATIONS. THE J.U.L.I.E NUMBER IS 1 (800) 892-0123. A MINIMUM 48 HOURS ADVANCE NOTICE IS REQUIRED. SEE SPECIAL PROVISIONS FOR STATUS OF UTILITIES WITH UTILITY COMPANIES LISTED.
- THE CONTRACTOR SHALL BE RESPONSIBLE FOR REPAIRS TO ANY UTILITY LINES AND EXISTING IMPROVEMENTS TO REMAIN THAT ARE DAMAGED AS A RESULT OF THE WORK.
- WHERE PROPOSED CONSTRUCTION ABUTS EXISTING APPURTENANCES, A SAW CUT SHALL BE MADE TO ACHIEVE A NEAT BUTT JOINT. SAW CUTS WILL NOT BE PAID FOR SEPARATELY BUT SHALL BE CONSIDERED INCLUDED IN THE TYPE OF WORK ENCOUNTERED.
- ALL ELEVATIONS SHOWN ON THE PLANS ARE BASED ON NAVD 88 DATUM.
- WHERE SECTION OR SUBSECTION MONUMENTS ARE ENCOUNTERED, THE ENGINEER SHALL BE NOTIFIED BEFORE SUCH MONUMENTS ARE REMOVED. THE CONTRACTOR SHALL PROTECT AND CAREFULLY PRESERVE ALL MONUMENTS UNTIL AN AUTHORIZED SURVEYOR OR AGENT HAS WITNESSED OR OTHERWISE REFERENCED THEIR LOCATION. THE CONTRACTOR SHALL BE RESPONSIBLE FOR HAVING AN AUTHORIZED SURVEYOR REESTABLISH ANY SECTION OR SUBSECTION MONUMENTS DESTROYED BY HIS OPERATIONS.
- ANY EXISTING ROAD SIGNS THAT INTERFERE WITH CONSTRUCTION SHALL BE RELOCATED AS DIRECTED BY THE ENGINEER. AFTER CONSTRUCTION IS COMPLETE, THE CONTRACTOR SHALL REPLACE SIGNS AS DIRECTED BY THE ENGINEER. THE COST FOR THIS WORK WILL NOT BE PAID FOR SEPARATELY BUT SHALL BE INCLUDED IN THE COST OF THE TRAFFIC CONTROL ITEMS.
- THE ENGINEER SHALL BE THE SOLE JUDGE CONCERNING CURING TIME FOR THE VARIOUS BITUMINOUS LIFTS.
- FOR STABILIZATION, ALL TYPE III BARRICADES SHALL REQUIRE A MINIMUM OF FOUR SANDBAGS PER BARRICADE.
- REMOVAL OF EXISTING PAVEMENT TO REPLACE CROSS ROAD CULVERTS WILL NOT BE PAID FOR SEPARATELY BUT SHALL BE INCLUDED IN THE COST OF THE PROPOSED PIPE CULVERT. THE TOP 12" OF THE TRENCH SHALL BE BACKFILLED WITH AGGERGATE BASE COURSE TYPE B.

COMMITMENTS

AVOID DISTURBING TWO WETLAND AREAS
(SEE SPECIAL PROVISIONS)

THE FOLLOWING MIXTURE REQUIREMENTS ARE APPLICABLE FOR THIS PROJECT

MIXTURE USES	HOT-MIX ASPHALT SURFACE COURSE MIX "C" N50	LEVEL BINDER (MACHINE METHOD) N50
AC/PG:	PG 64-22	PG 64-22
DESIGN AIR VOIDS	4.0 @ NDESIGN = 50	4.0 @ NDESIGN = 50
MIXTURE COMPOSITION (GRADATION MIXTURE)	IL 9.5	IL 9.5, 19.0
FRICTION AGGREGATE	MIX "C"	N/A

RATES OF APPLICATION

THE FOLLOWING FACTORS WERE USED FOR ESTIMATING PLAN QUANTITIES AND SHALL NOT BE USED FOR THE BASIS OF FINAL QUANTITIES.

HOT MIX ASPHALT	0.056 TONS/SQ. YD./INCH
BITUMINOUS MATERIALS (PRIME COAT)	0.1 GAL/SQ. YD. (ON SOIL-CEMENT OR PAVEMENT)
RIP RAP	0.35 GAL/SQ YD (ON AGGREGATE)
AGGREGATE	1.5 TON/CU YD 2.05 TON/CU. YD.



JOB # 2184	DESIGNED - NAK	REVISED -
FILE NAME # 2184gennotes.dgn	DRAWN - TJD	REVISED -
PLOT SCALE # 2.0000" / IN.	CHECKED - NAK	REVISED -
PLOT DATE # 12/5/2013	DATE - 7/27/2010	REVISED -

MACOUPIN COUNTY
CH 12 IMPROVEMENTS

GENERAL NOTES

F.A.S. RTE.	SECTION	COUNTY	TOTAL SHEETS	SHEET NO.
732	01-00079-00-FP	MACOUPIN	141	2
FED. ROAD DIST. NO. ILLINOIS FED. AID PROJECT			CONTRACT NO. 93574	

SCALE: SHEET NO. OF SHEETS STA. TO STA.

LOCATION OF WORK				FUNDING		
				HSIP STA. 42+00 TO STA. 103+00 STA. 165+00 TO STA. 208+00	STR STA. 6+00 TO STA. 42+00 STA. 103+00 TO STA. 165+00 STA. 208+00 TO STA. 235+78	LOCAL STA. -1+78 TO STA. 6+00 STA. 235+78 TO STA. 247+50
SUMMARY OF QUANTITIES				CONSTRUCTION TYPE CODE		
CODE NO.	ITEM	UNIT	TOTAL QUANTITY	0004	0004	0004
20100110	TREE REMOVAL (8 TO 15 UNITS DIAMETER)	UNIT	362	252	110	
20100210	TREE REMOVAL (OVER 15 UNITS DIAMETER)	UNIT	84	42	42	
20100500	TREE REMOVAL, ACRES	ACRE	1.2	0.8	0.4	
20200100	EARTH EXCAVATION	CU YD	22,239	14,775	7,464	
20200500	EARTH EXCAVATION (WIDENING)	CU YD	4,616	2,311	2,305	
21400100	GRADING AND SHAPING DITCHES	FOOT	50	50		
25100900	TURF REINFORCEMENT MAT	SQ YD	39	39		
28000250	TEMPORARY EROSION CONTROL SEEDING	POUND	1,484	900	584	
28000305	TEMPORARY DITCH CHECKS	FOOT	1,208	584	624	
28000400	PERIMETER EROSION BARRIER	FOOT	6,671	2,764	3,907	
28000500	INLET AND PIPE PROTECTION	EACH	61	35	26	
28100207	STONE RIPRAP, CLASS A4	TON	249	161	88	
28200200	FILTER FABRIC	SQ YD	358	223	133	
35101400	AGGREGATE BASE COURSE, TYPE B	TON	11,898	7,146	4,752	
35200420	PROCESSING SOIL-CEMENT BASE COURSE 12"	SQ YD	60,011	30,044	29,967	
35200500	CEMENT	100 WT	73,993	37,045	36,948	
40200800	AGGREGATE SURFACE COURSE, TYPE B	TON	412	269	143	
40300300	BITUMINOUS MATERIALS (COVER AND SEAL COATS)	GALLON	24,336	12,350	11,986	
40300600	SEAL COAT AGGREGATE	TON	761	386	375	
40600100	BITUMINOUS MATERIALS (PRIME COAT)	GALLON	14,747	8,050	6,697	
40600300	AGGREGATE (PRIME COAT)	TON	130	82	68	
40800982	HOT-MIX ASPHALT SURFACE REMOVAL - BUTT JOINT	SQ YD	541	325	216	
40803080	HOT-MIX ASPHALT BINDER COURSE, IL-19.0, N50	TON	10,045	5,410	4,635	
40603310	HOT-MIX ASPHALT SURFACE COURSE, MIX "C", N50	TON	5,319	2,508	2,811	
40800050	INCIDENTAL HOT-MIX ASPHALT SURFACING	TON	634	320	314	
42300400	PORTLAND CEMENT CONCRETE DRIVEWAY PAVEMENT, 8 INCH	SQ YD	136	136		
44000155	HOT-MIX ASPHALT SURFACE REMOVAL, 1 1/2"	SQ YD	5,521		5,521	
44000200	DRIVEWAY PAVEMENT REMOVAL	SQ YD	601	253	348	
44000400	GUTTER REMOVAL	FOOT	6,441	6,441		
48101200	AGGREGATE SHOULDERS, TYPE B	TON	7,577	3,733	3,844	
48203029	HOT-MIX ASPHALT SHOULDERS, 8"	SQ YD	1,308	1,308		
50102400	CONCRETE REMOVAL	CU YD	8.2		8.2	
50104400	CONCRETE HEADWALL REMOVAL	EACH	8	6	2	
50105220	PIPE CULVERT REMOVAL	FOOT	1,962	1,115	847	
50800105	REINFORCEMENT BARS	POUND	47,670	37,580	10,080	
54001001	BOX CULVERT END SECTIONS, CULVERT NO.1	EACH	2		2	
54001002	BOX CULVERT END SECTIONS, CULVERT NO.2	EACH	1	1		
54001003	BOX CULVERT END SECTIONS, CULVERT NO.3	EACH	2	2		
54001004	BOX CULVERT END SECTIONS, CULVERT NO. 4	EACH	1		1	
54001005	BOX CULVERT END SECTIONS, CULVERT NO. 5	EACH	2		2	
54001006	BOX CULVERT END SECTIONS, CULVERT NO. 6	EACH	2		2	
54001007	BOX CULVERT END SECTIONS, CULVERT NO. 7	EACH	2		2	
54001008	BOX CULVERT END SECTIONS, CULVERT NO. 8	EACH	1		1	
54001009	BOX CULVERT END SECTIONS, CULVERT NO. 9	EACH	1		1	
54001010	BOX CULVERT END SECTIONS, CULVERT NO. 10	EACH	1		1	
54001011	BOX CULVERT END SECTIONS, CULVERT NO. 11	EACH	1		1	
54002020	EXPANSION BOLTS 3/4 INCH	EACH	580	264	316	
54003000	CONCRETE BOX CULVERTS	CU YD	287.7	229.3	58.4	
54010302	PRECAST CONCRETE BOX CULVERTS 3' X 2'	FOOT	3		3	
54010303	PRECAST CONCRETE BOX CULVERTS 3' X 3'	FOOT	4		4	

LOCATION OF WORK				FUNDING		
				HSIP STA. 42+00 TO STA. 103+00 STA. 165+00 TO STA. 208+00	STR STA. 6+00 TO STA. 42+00 STA. 103+00 TO STA. 165+00 STA. 208+00 TO STA. 235+78	LOCAL STA. -1+78 TO STA. 6+00 STA. 235+78 TO STA. 247+50
SUMMARY OF QUANTITIES				CONSTRUCTION TYPE CODE		
CODE NO.	ITEM	UNIT	TOTAL QUANTITY	0004	0004	0004
54010402	PRECAST CONCRETE BOX CULVERTS 4' X 2'	FOOT	4		4	
54213660	PRECAST REINFORCED CONCRETE FLARED END SECTIONS 15"	EACH	3	3		
54213663	PRECAST REINFORCED CONCRETE FLARED END SECTIONS 18"	EACH	24	18	6	
54213669	PRECAST REINFORCED CONCRETE FLARED END SECTIONS 24"	EACH	4	2	2	
54213675	PRECAST REINFORCED CONCRETE FLARED END SECTIONS 30"	EACH	5	4	1	
54213681	PRECAST REINFORCED CONCRETE FLARED END SECTIONS 36"	EACH	2		2	
54214503	PRECAST REINFORCED CONCRETE FLARED END SECTIONS, EQUIVALENT ROUND-SIZE 18"	EACH	2	2		
54216560	REINFORCED CONCRETE PIPE TEE, 18" PIPE WITH 15" RISER	EACH	1	1		
54248510	CONCRETE COLLAR	CU YD	5.5	0.8	4.7	
59300100	CONTROLLED LOW-STRENGTH MATERIAL	CU YD	224	123	101	
60224066	MANHOLES, TYPE A, 6'-DIAMETER, WITH MEDIAN INLET (604101)	EACH	1		1	
60236200	INLETS, TYPE A, TYPE B GRATE	EACH	2		2	
60240301	INLETS, TYPE B, TYPE B GRATE	EACH	1	1		
60600095	CLASS SI CONCRETE (OUTLET)	CU YD	35.6	35.6		
63000001	STEEL PLATE BEAM GUARDRAIL, TYPE A, 6 FOOT POSTS	FOOT	1,025		1,025	
63100080	TRAFFIC BARRIER TERMINAL, TYPE 5R	EACH	4		4	
63100167	TRAFFIC BARRIER TERMINAL, TYPE 1 (SPECIAL) TANGENT	EACH	6		6	
63200310	GUARDRAIL REMOVAL	FOOT	1,163	747	416	
67000500	ENGINEER'S FIELD OFFICE, TYPE B	CAL MO	8	4	4	
67100100	MOBILIZATION	L SUM	1	1		
70100450	TRAFFIC CONTROL AND PROTECTION, STANDARD 701201	L SUM	1	1		
70100460	TRAFFIC CONTROL AND PROTECTION, STANDARD 701306	L SUM	1	1		
70101830	TRAFFIC CONTROL AND PROTECTION, STANDARD BLR 21	L SUM	1	1		
70101835	TRAFFIC CONTROL AND PROTECTION, STANDARD BLR 22	L SUM	1	1		
70300100	SHORT TERM PAVEMENT MARKING	FOOT	10,387	5,200	5,187	
70300220	TEMPORARY PAVEMENT MARKING - LINE 4"	FOOT	84,386	42,488	34,738	7,160
70301000	WORK ZONE PAVEMENT MARKING REMOVAL	SQ FT	693	347	346	
78000200	THERMOPLASTIC PAVEMENT MARKING - LINE 4"	FOOT	84,386	42,488	34,738	7,160
78100100	RAISED REFLECTIVE PAVEMENT MARKER	EACH	275	131	123	21
78200410	GUARDRAIL MARKERS, TYPE A	EACH	19		19	
78201000	TERMINAL MARKER - DIRECT APPLIED	EACH	6		6	
542A0213	PIPE CULVERTS, CLASS A, TYPE 1 8"	FOOT	8	8		
542A0220	PIPE CULVERTS, CLASS A, TYPE 1 15"	FOOT	60	60		
542A0223	PIPE CULVERTS, CLASS A, TYPE 1 18"	FOOT	630	486	144	
542A0229	PIPE CULVERTS, CLASS A, TYPE 1 24"	FOOT	118	64	54	
542A0235	PIPE CULVERTS, CLASS A, TYPE 1 30"	FOOT	234	154	80	
542A0241	PIPE CULVERTS, CLASS A, TYPE 1 36"	FOOT	56		56	
542A5473	PIPE CULVERTS, CLASS A, TYPE 1 EQUIVALENT ROUND-SIZE 18"	FOOT	148	148		
542D0217	PIPE CULVERTS, CLASS D, TYPE 1 12"	FOOT	36	36		
542D0220	PIPE CULVERTS, CLASS D, TYPE 1 15"	FOOT	1,700	890	810	
542D0223	PIPE CULVERTS, CLASS D, TYPE 1 18"	FOOT	74		74	
LR403300	SURFACE PROFILE MILLING	SQ YD	60,002	30,044	29,958	
X2501000	SEEDING, CLASS 2 (SPECIAL)	ACRE	14.8	9.0	5.8	
X2810106	STONE RIPRAP, CLASS A3 (SPECIAL)	SQ YD	412	280	132	
X5400504	PRECAST CONCRETE BOX CULVERTS 2' X 2' (SPECIAL)	FOOT	46	3	43	
X6062700	CONCRETE GUTTER, TYPE A (SPECIAL)	FOOT	1,116	1,116		
Z0076600	TRAINEES	HOURL	500	250	250	
# * Z0076604	TRAINEES TRAINING PROGRAM GRADUATE	HOURL	500	250	250	

* SEE SPECIAL PROVISIONS Δ SPECIALTY ITEM # 0042



JOB - 2184	DESIGNED - NAK	REVISED -
FILE NAME - 2184.swg.dgn	DRAWN - TJD	REVISED -
PLOT SCALE - 2.0000' / IN.	CHECKED - NAK	REVISED -
PLOT DATE - 12/9/2013	DATE - 7/13/2011	REVISED -

**MACOUPIN COUNTY
CH 12 IMPROVEMENTS**

SUMMARY OF QUANTITIES

SCALE:	SHEET NO.	OF	SHEETS	STA.	TO STA.
--------	-----------	----	--------	------	---------

F.A.S. RTE.	SECTION	COUNTY	TOTAL SHEETS	SHEET NO.
732	01-00079-00-FP	MACOUPIN	141	3
CONTRACT NO. 93574				
FED. ROAD DIST. NO. ILLINOIS FED. AID PROJECT				

EXISTING TYPICAL CROSS SECTION

STATION	TO	STATION
LT 6+00		43+00
RT 6+00		42+62
66+46.23		86+54.19
99+78.46		127+50
149+50		169+21.89
182+19.21		186+26.70
LT 207+00		229+55.18
RT 208+00		229+55.18
235+02.55		235+75

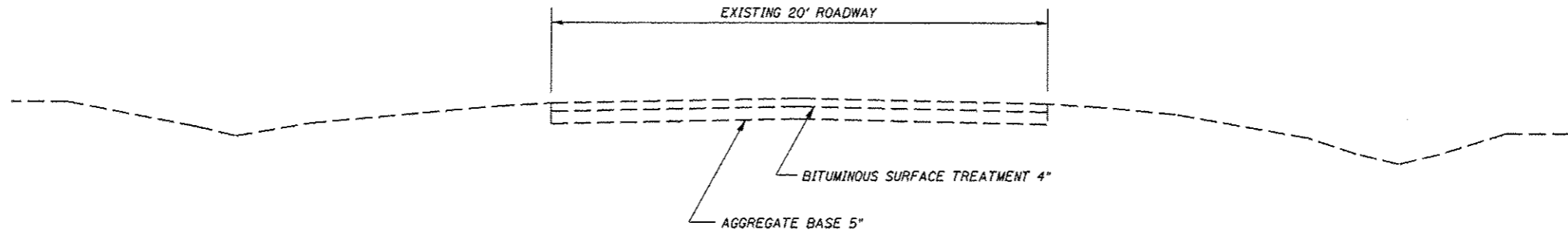

EXISTING TYPICAL CROSS SECTION

OMISSION
STA 142+47.59 TO STA 143+98.71

STATION	TO	STATION
127+50.00		142+47.59
143+98.71		149+50.00

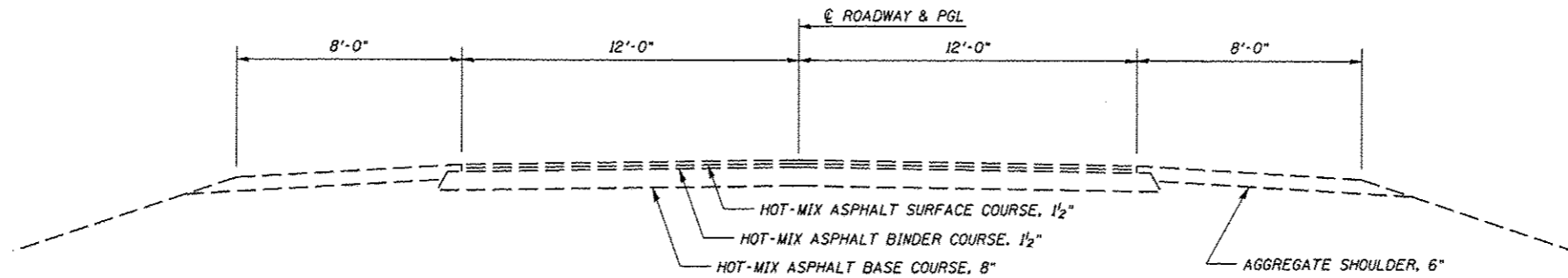

EXISTING TYPICAL CROSS SECTION

STATION	TO	STATION
LT 43+00		53+21.47
RT 42+62		53+21.47
LT 192+22.98		207+00
RT 192+22.98		208+00

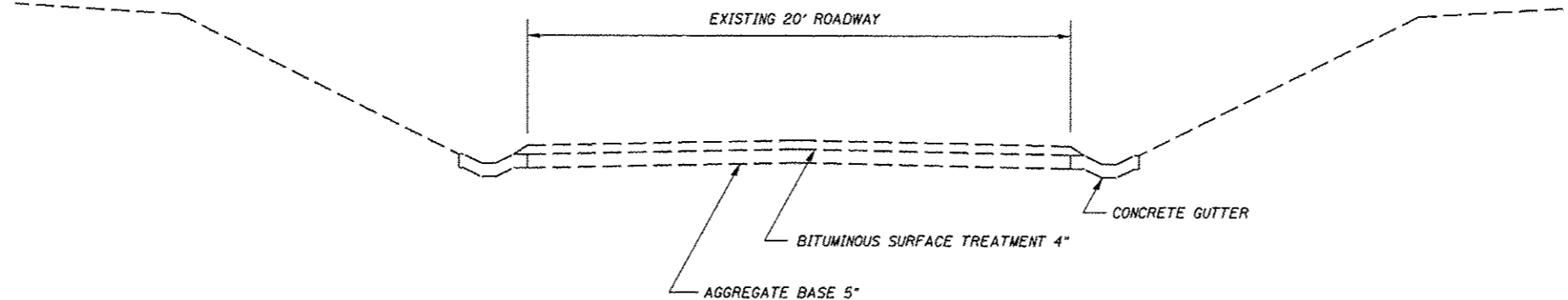

EXISTING TYPICAL CROSS SECTION

STATION	TO	STATION
86+54.19		99+78.46
RT 186+26.70		191+00
LT 186+26.70		192+00
229+55.18		235+02.55

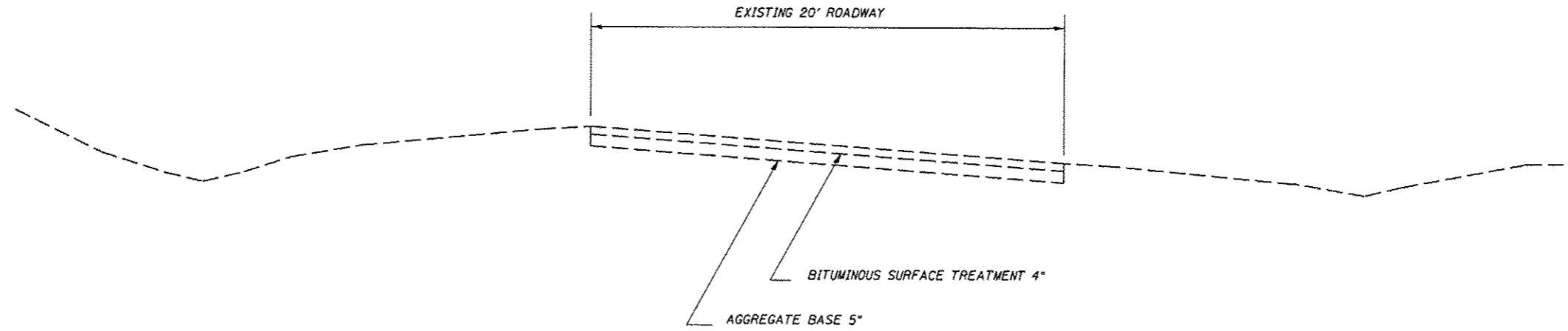

EXISTING TYPICAL CROSS SECTION

STATION	TO	STATION
RT 191+00		199+22.98
LT 192+00		199+22.98

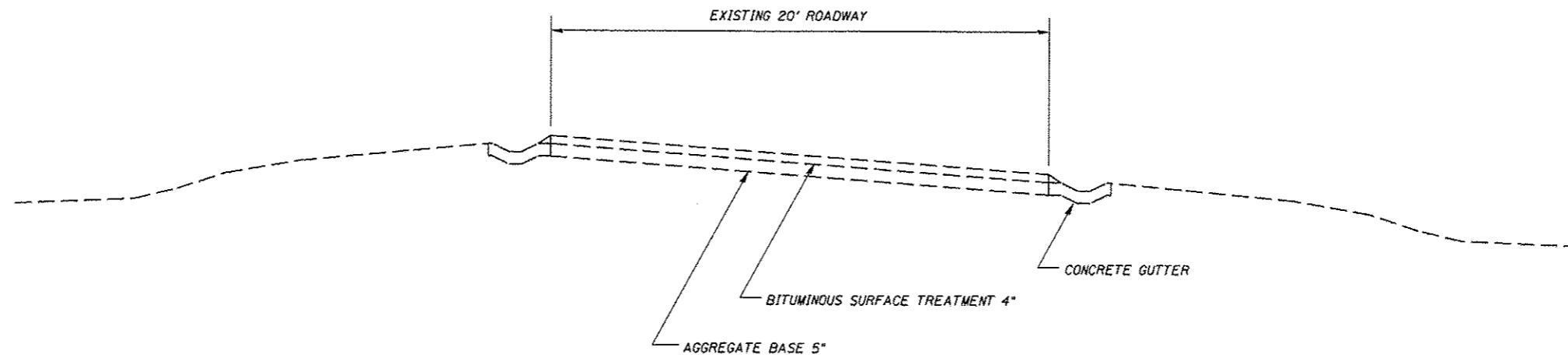

EXISTING TYPICAL CROSS SECTION

STATION	TO	STATION
LT 53+21.47		58+00
RT 53+21.47		57+63

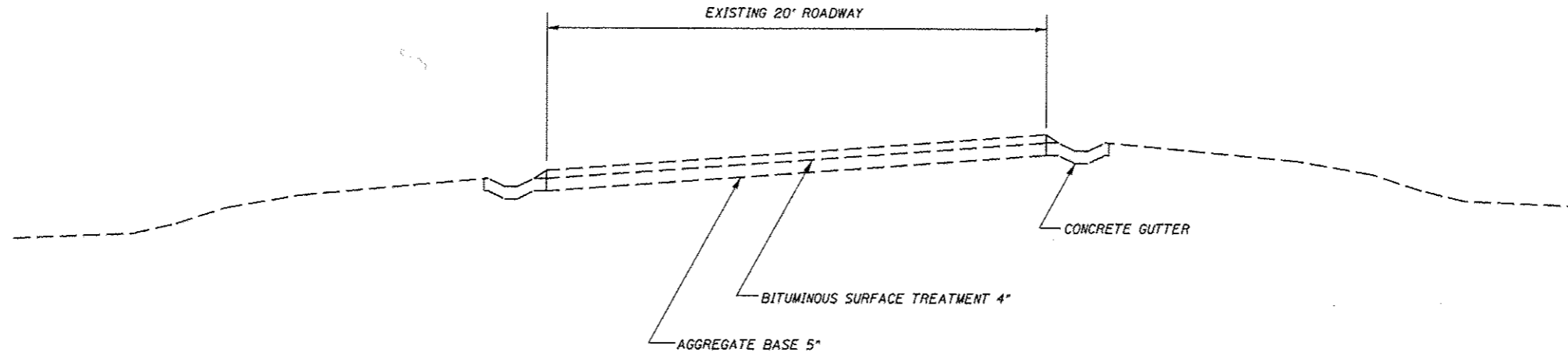

EXISTING TYPICAL CROSS SECTION

STATION	TO	STATION
LT 58+00		66+46.23
RT 57+63		66+46.23
169+21.89		182+19.21

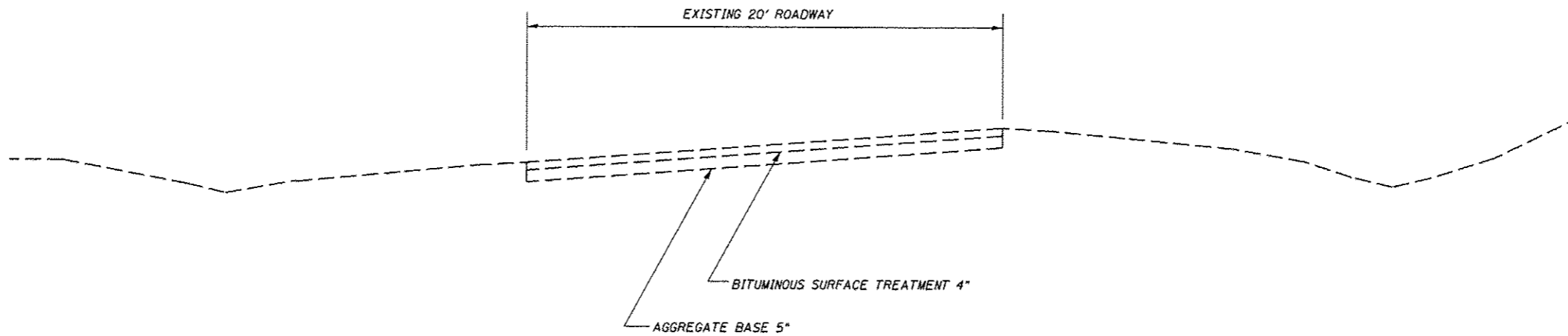

① PROPOSED TYPICAL CROSS SECTION

STATION	TO	STATION
LT 6+00		43+00 ②
RT 6+00		42+62 ②
④ 66+45.73		86+54.49 ⑤

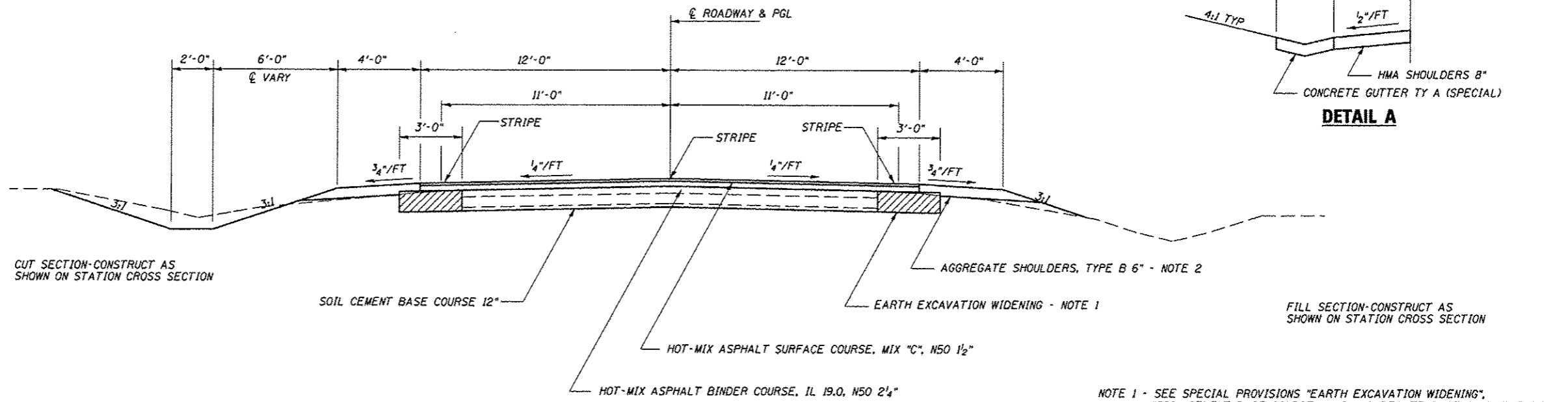

- NOTE 1 - SEE SPECIAL PROVISIONS "EARTH EXCAVATION WIDENING", "SOIL-CEMENT BASE COURSE", AND "AGGREGATE BASE COURSE, TYPE B"
- NOTE 2 - CONSTRUCT HMA SHOULDERS 8" AND CONCRETE GUTTER TY A (SPECIAL) LEFT STA 42+58.40 TO STA 45+36.00 AS SHOWN IN DETAIL A

② PROPOSED TYPICAL CROSS SECTION

STATION	TO	STATION
① LT 43+00		47+50 ①②
① RT 42+62		47+50 ①②
② 49+00		53+21.47 ③

PAVEMENT DESIGN

STA 6+00 TO STA 88+00
 DESIGN TRAFFIC 1,660 (20)
 PV = 88% SU = 5% MU = 7%
 D₁ = 3.75
 3 3/4" HMA BINDER/SURFACE A₁ = 0.36
 12" SOIL-CEMENT BASE COURSE A₂ = 0.20

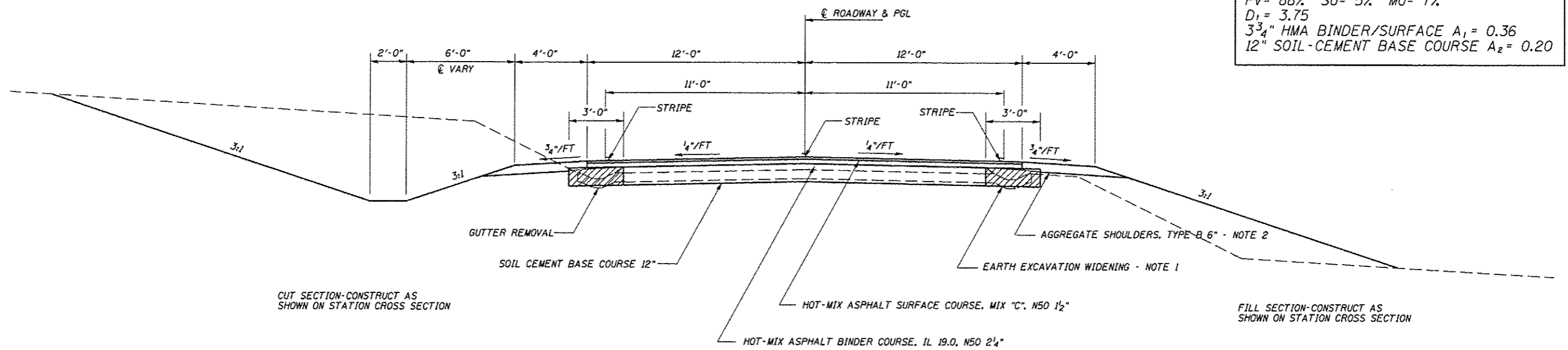

③ PROPOSED TYPICAL CROSS SECTION

STATION	TO	STATION
② LT 53+21.47		58+00 ④
② RT 53+21.47		57+63 ④

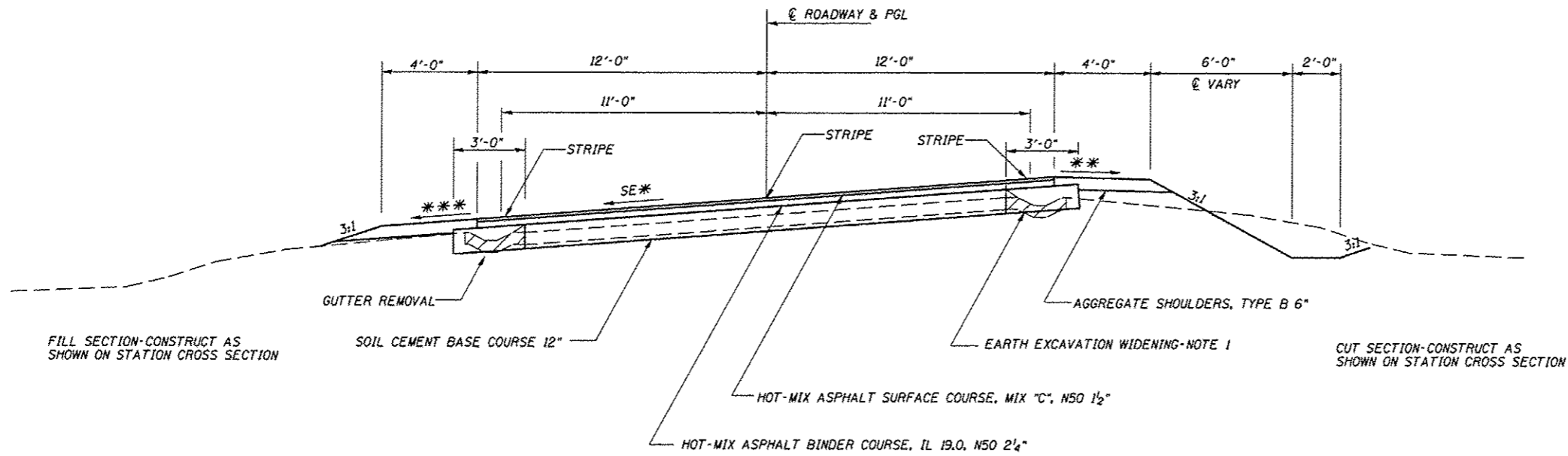

- * SEE PLAN AND PROFILE SHEETS FOR SUPERELEVATION (SE) RATES AND FOR TRANSITION LIMITS
- ** WHEN THE SUPERELEVATION RATE OF THE PAVEMENT IS BETWEEN 0% AND 4%, THE SHOULDER SHALL BE SLOPED AT 6%. WHEN THE SUPERELEVATION RATE OF THE PAVEMENT EXCEEDS 4%, THE SHOULDER SHALL BE SLOPED SO THAT THE ALGEBRAIC DIFFERENCE BETWEEN PAVEMENT AND SHOULDER WILL NOT BE GREATER THAN 10%
- *** SLOPE SHALL BE THE SAME AS THE SUPERELEVATION RATE BUT NOT LESS THAN 6%

NOTE 1 - SEE SPECIAL PROVISIONS "EARTH EXCAVATION WIDENING", "SOIL-CEMENT BASE COURSE", AND "AGGREGATE BASE COURSE, TYPE B"

④ PROPOSED TYPICAL CROSS SECTION

STATION	TO	STATION
③ LT 58+00		66+45.73 ①
③ RT 57+63		66+45.73 ①

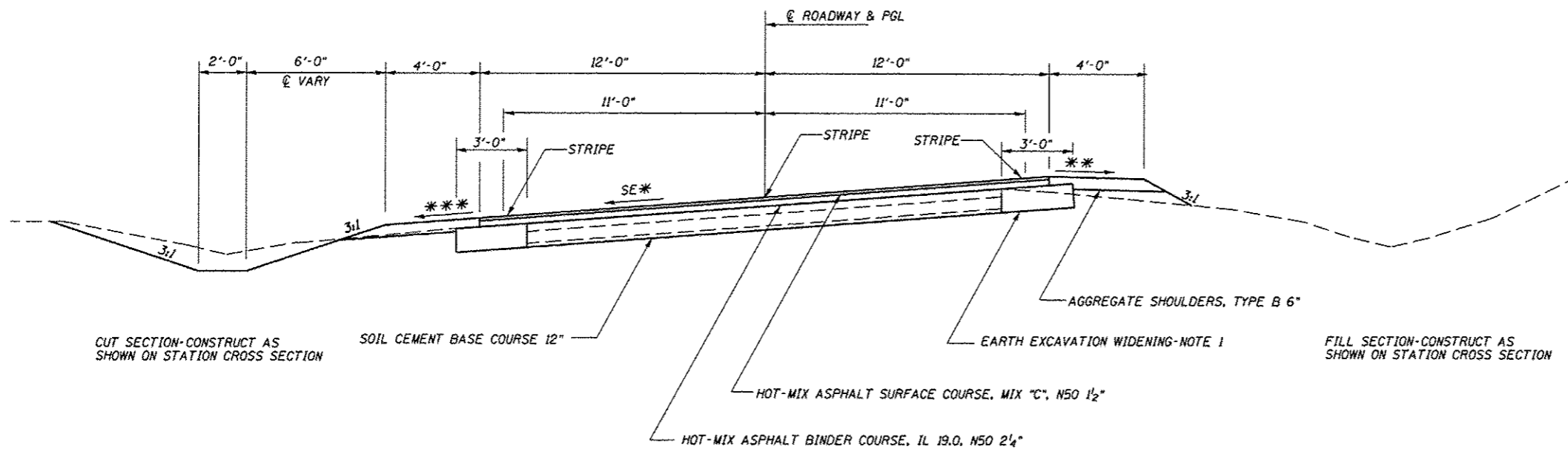

- * SEE PLAN AND PROFILE SHEETS FOR SUPERELEVATION (SE) RATES AND FOR TRANSITION LIMITS
- ** WHEN THE SUPERELEVATION RATE OF THE PAVEMENT IS BETWEEN 0% AND 4%, THE SHOULDER SHALL BE SLOPED AT 6%. WHEN THE SUPERELEVATION RATE OF THE PAVEMENT EXCEEDS 4%, THE SHOULDER SHALL BE SLOPED SO THAT THE ALGEBRAIC DIFFERENCE BETWEEN PAVEMENT AND SHOULDER WILL NOT BE GREATER THAN 10%
- *** SLOPE SHALL BE THE SAME AS THE SUPERELEVATION RATE BUT NOT LESS THAN 6%

⑤ PROPOSED TYPICAL CROSS SECTION

STATION TO STATION
① 86+54.49 88+00 ⑥

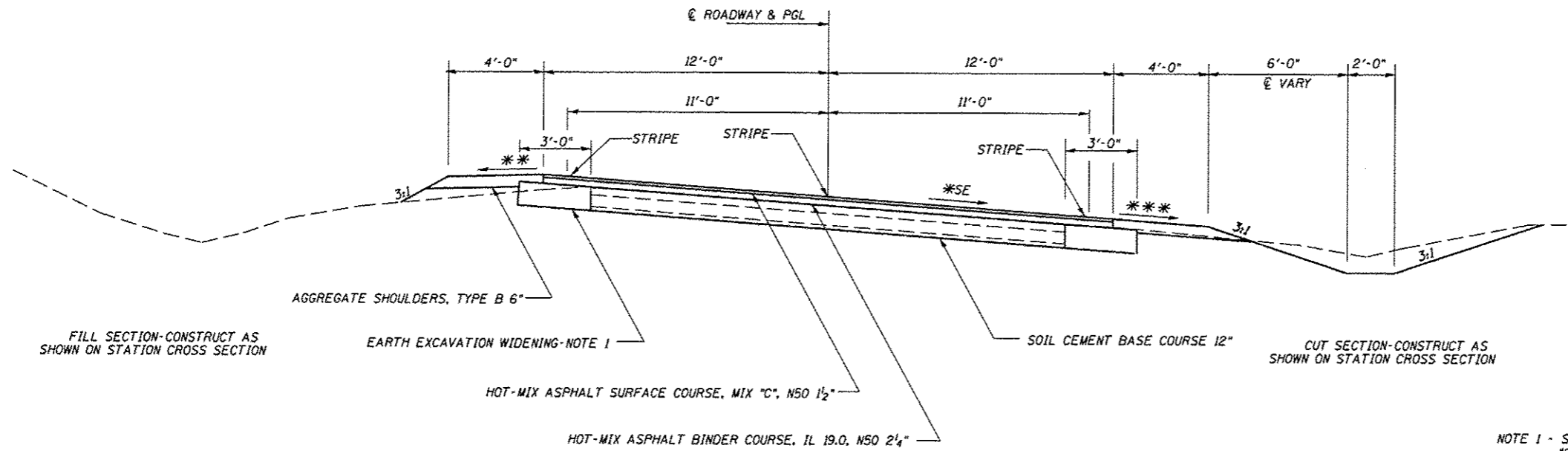

- * SEE PLAN AND PROFILE SHEETS FOR SUPERELEVATION (SE) RATES AND FOR TRANSITION LIMITS
- ** WHEN THE SUPERELEVATION RATE OF THE PAVEMENT IS BETWEEN 0% AND 4%, THE SHOULDER SHALL BE SLOPED AT 6%. WHEN THE SUPERELEVATION RATE OF THE PAVEMENT EXCEEDS 4%, THE SHOULDER SHALL BE SLOPED SO THAT THE ALGEBRAIC DIFFERENCE BETWEEN PAVEMENT AND SHOULDER WILL NOT BE GREATER THAN 10%
- *** SLOPE SHALL BE THE SAME AS THE SUPERELEVATION RATE BUT NOT LESS THAN 6%

NOTE 1 - SEE SPECIAL PROVISIONS "EARTH EXCAVATION WIDENING", "SOIL-CEMENT BASE COURSE", AND "AGGREGATE BASE COURSE, TYPE B"

⑥ PROPOSED TYPICAL CROSS SECTION

STATION TO STATION
⑤ 88+00 99+78.46 ⑦
⑦ RT 186+26.70 187+00 ⑫
⑦ LT 186+26.70 187+00 ⑫
⑫ 190+00 191+00 ⑨
⑫ 190+00 192+00 ⑨
⑦ 229+55.18 235+02.55 ⑦

NOTE 2 - CONSTRUCT HMA SHOULDERS 8" LEFT AND RIGHT STA 93+00.00 TO STA 96+00.00

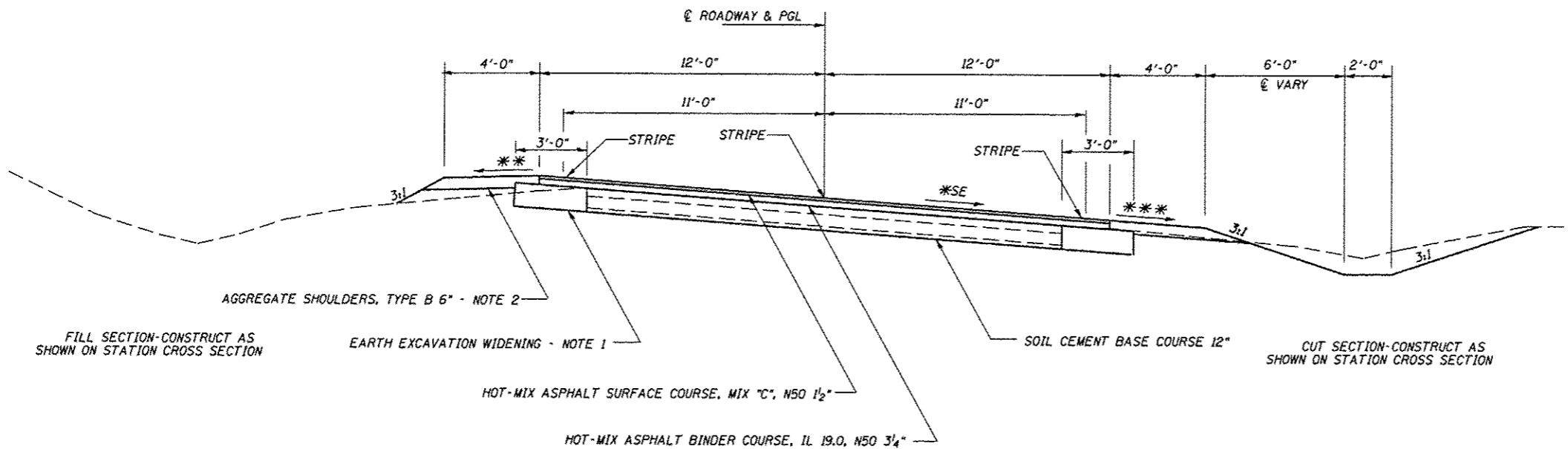

PAVEMENT DESIGN
STA 88+00 TO STA 235+78
DESIGN TRAFFIC 2,850 (20)
PV= 88% SU= 5% MU= 7%
D₁ = 4.07
4 3/4" HMA BINDER/SURFACE A₁ = 0.36
12" SOIL-CEMENT BASE COURSE A₂ = 0.20

- * SEE PLAN AND PROFILE SHEETS FOR SUPERELEVATION (SE) RATES AND FOR TRANSITION LIMITS
- ** WHEN THE SUPERELEVATION RATE OF THE PAVEMENT IS BETWEEN 0% AND 4%, THE SHOULDER SHALL BE SLOPED AT 6%. WHEN THE SUPERELEVATION RATE OF THE PAVEMENT EXCEEDS 4%, THE SHOULDER SHALL BE SLOPED SO THAT THE ALGEBRAIC DIFFERENCE BETWEEN PAVEMENT AND SHOULDER WILL NOT BE GREATER THAN 10%
- *** SLOPE SHALL BE THE SAME AS THE SUPERELEVATION RATE BUT NOT LESS THAN 6%

7 PROPOSED TYPICAL CROSS SECTION

STATION	TO	STATION
7 99+78.46		127+50
149+50		169+21.89 8
8 182+19.21		186+26.70 6
10 LT 207+00		224+50 15
10 RT 203+00		223+00 15
15 227+00		229+55.18 6
6 235+02.55		235+75

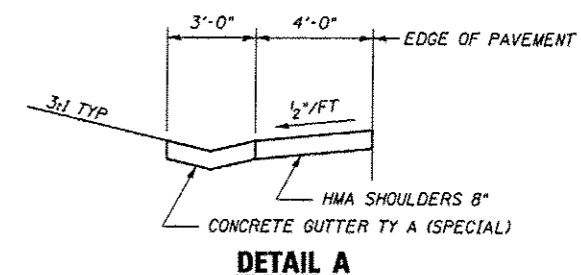
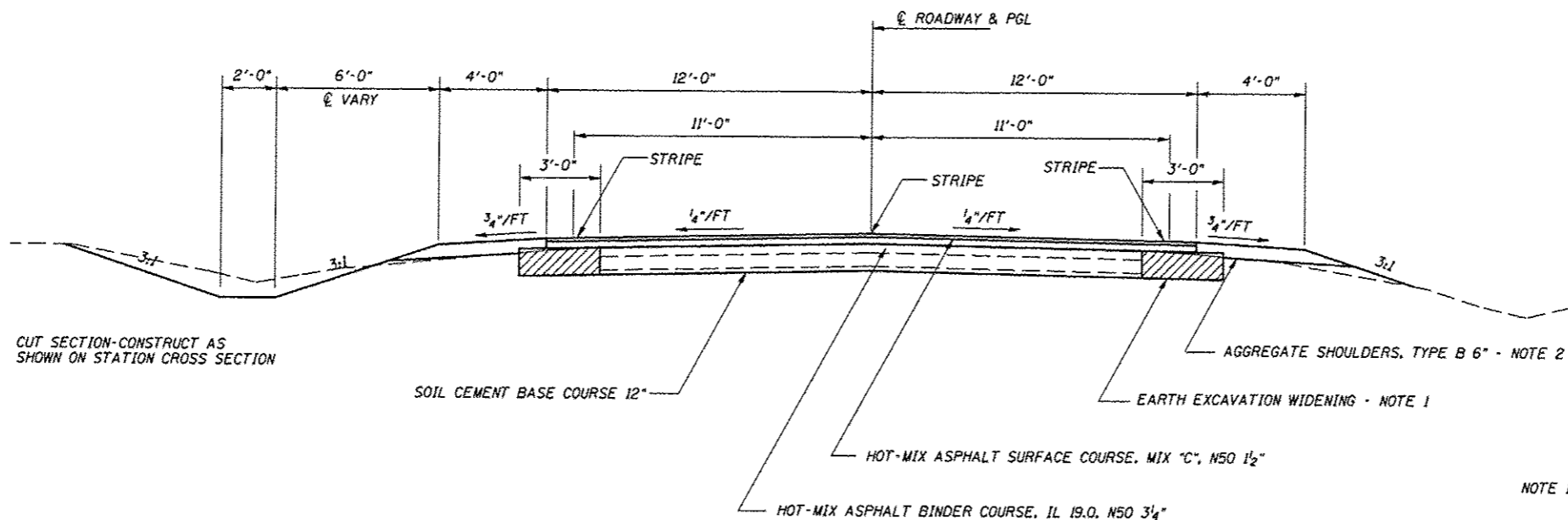

CUT SECTION-CONSTRUCT AS SHOWN ON STATION CROSS SECTION

FILL SECTION-CONSTRUCT AS SHOWN ON STATION CROSS SECTION

- NOTE 1 - SEE SPECIAL PROVISIONS "EARTH EXCAVATION WIDENING", "SOIL-CEMENT BASE COURSE", AND "AGGREGATE BASE COURSE, TYPE B"
- NOTE 2 - CONSTRUCT HMA SHOULDERS 8" AND CONCRETE GUTTER TY A (SPECIAL) LEFT AND RIGHT STA 204+00.00 TO STA 207+75.00 AS SHOWN IN DETAIL A

8 PROPOSED TYPICAL CROSS SECTION

STATION	TO	STATION
7 169+21.89		182+19.21 7

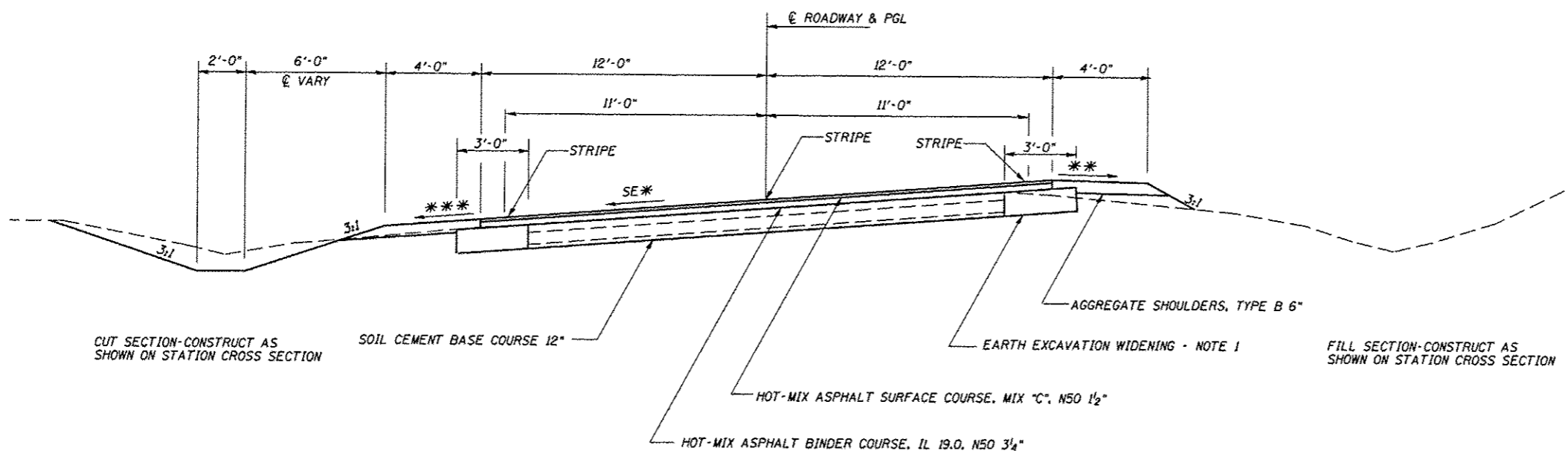

CUT SECTION-CONSTRUCT AS SHOWN ON STATION CROSS SECTION

FILL SECTION-CONSTRUCT AS SHOWN ON STATION CROSS SECTION

- * SEE PLAN AND PROFILE SHEETS FOR SUPERELEVATION (SE) RATES AND FOR TRANSITION LIMITS
- ** WHEN THE SUPERELEVATION RATE OF THE PAVEMENT IS BETWEEN 0% AND 4%, THE SHOULDER SHALL BE SLOPED AT 6%. WHEN THE SUPERELEVATION RATE OF THE PAVEMENT EXCEEDS 4%, THE SHOULDER SHALL BE SLOPED SO THAT THE ALGEBRAIC DIFFERENCE BETWEEN PAVEMENT AND SHOULDER WILL NOT BE GREATER THAN 10%
- *** SLOPE SHALL BE THE SAME AS THE SUPERELEVATION RATE BUT NOT LESS THAN 6%

9 PROPOSED TYPICAL CROSS SECTION

STATION TO STATION
 ⑥ RT STA 191+00 196+00 ⑬
 ⑥ LT STA 192+00 196+00 ⑬

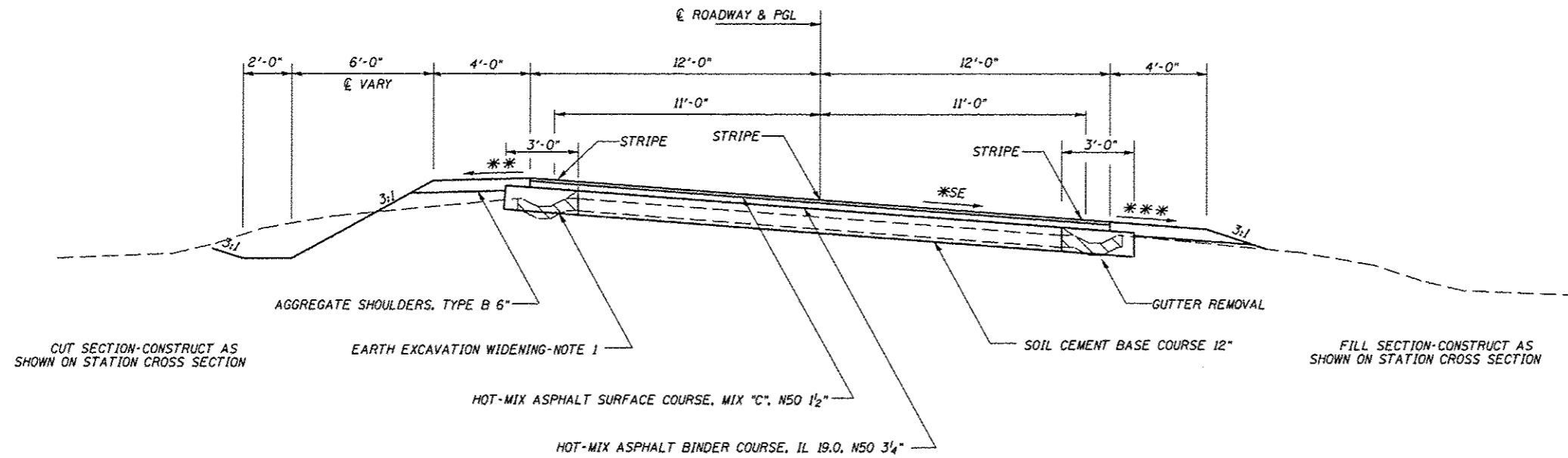

- * SEE PLAN AND PROFILE SHEETS FOR SUPERELEVATION (SE) RATES AND FOR TRANSITION LIMITS
- ** WHEN THE SUPERELEVATION RATE OF THE PAVEMENT IS BETWEEN 0% AND 4%, THE SHOULDER SHALL BE SLOPED AT 6%. WHEN THE SUPERELEVATION RATE OF THE PAVEMENT EXCEEDS 4%, THE SHOULDER SHALL BE SLOPED SO THAT THE ALGEBRAIC DIFFERENCE BETWEEN PAVEMENT AND SHOULDER WILL NOT BE GREATER THAN 10%
- *** SLOPE SHALL BE THE SAME AS THE SUPERELEVATION RATE BUT NOT LESS THAN 6%

NOTE 1 - SEE SPECIAL PROVISIONS "EARTH EXCAVATION WIDENING", "SOIL-CEMENT BASE COURSE", AND "AGGREGATE BASE COURSE, TYPE B"

10 PROPOSED TYPICAL CROSS SECTION

STATION TO STATION
 ⑭ LT 201+00 207+00 ⑦
 ⑭ RT 201+00 203+00 ⑦

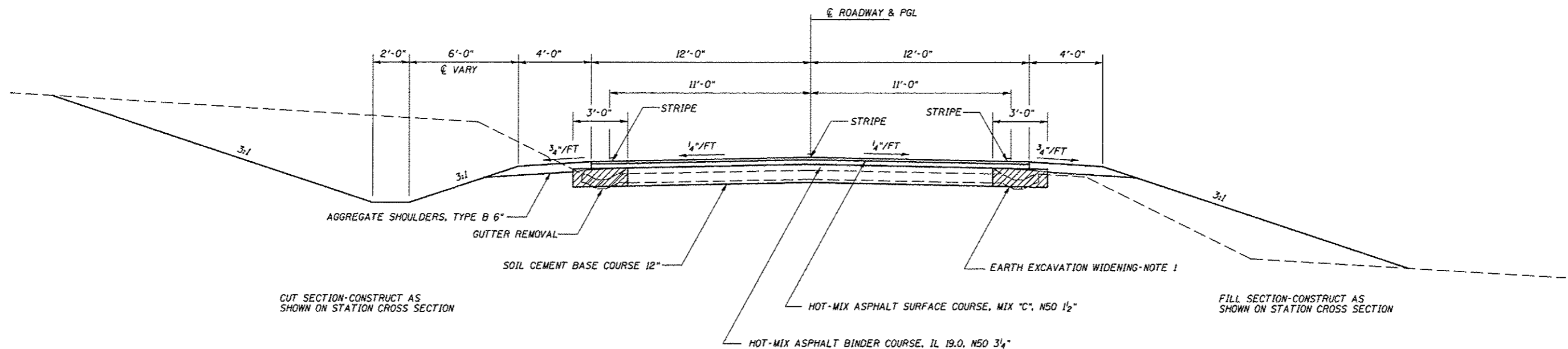

11 PROPOSED TYPICAL CROSS SECTION

STATION TO STATION
 ② 47+50 TO 49+00 ②

TRANSITION TO TYPICAL SECTION 2
 STA 49+00 TO STA 50+00

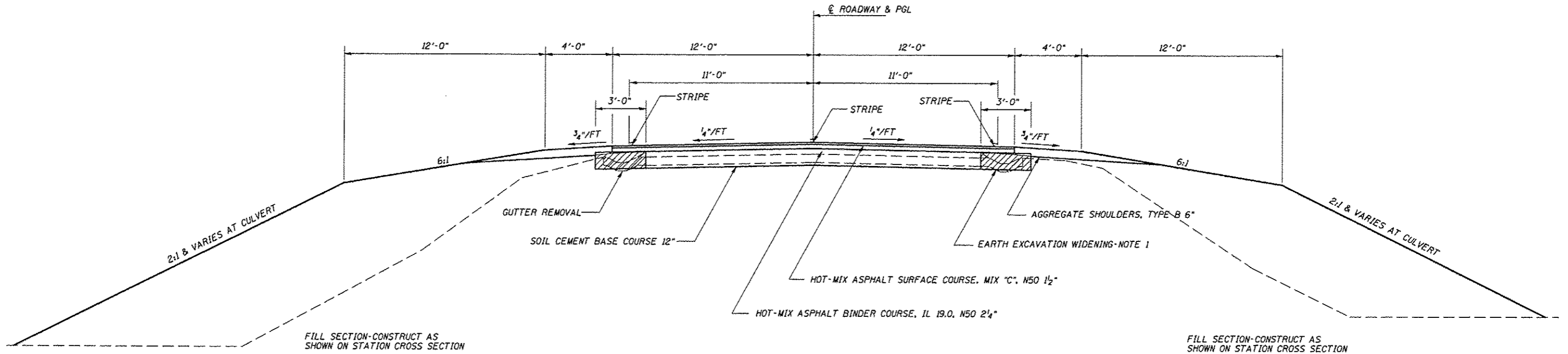

NOTE 1 - SEE SPECIAL PROVISIONS "EARTH EXCAVATION WIDENING",
 "SOIL-CEMENT BASE COURSE", AND "AGGREGATE BASE COURSE, TYPE B"

12 PROPOSED TYPICAL CROSS SECTION

STATION TO STATION
 ⑥ 187+00 TO 190+00 ⑥

TRANSITION EMBANKMENT FROM TYPICAL SECTION NO 6
 AT STA 187+00 TO TYPICAL SECTION NO 13 AT STA 188+00;
 FROM TYPICAL SECTION NO 13 AT STA 189+00 TO TYPICAL
 SECTION NO 6 AT STA 190+00.

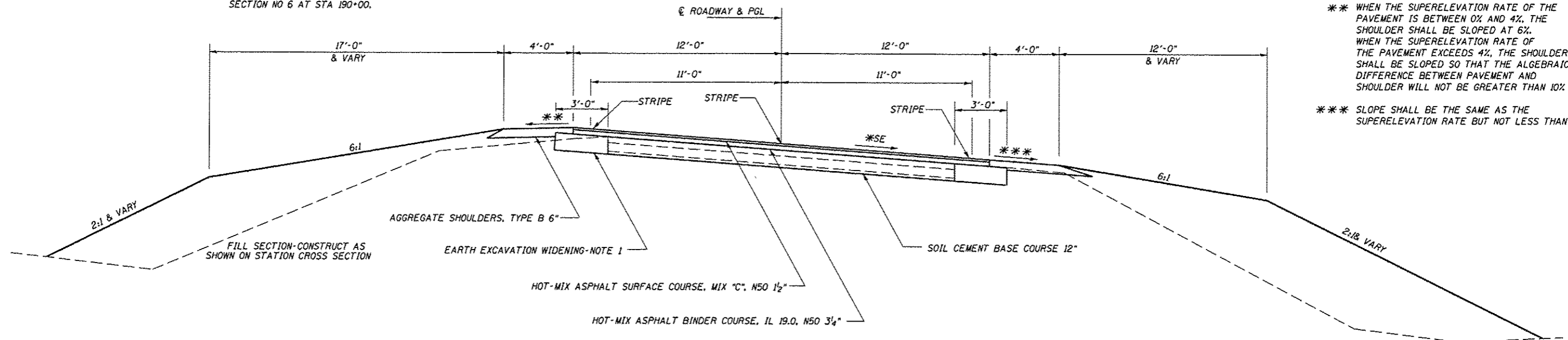

* SEE PLAN AND PROFILE SHEETS FOR
 SUPERELEVATION (SE) RATES AND
 FOR TRANSITION LIMITS

** WHEN THE SUPERELEVATION RATE OF THE
 PAVEMENT IS BETWEEN 0% AND 4%, THE
 SHOULDER SHALL BE SLOPED AT 6%.
 WHEN THE SUPERELEVATION RATE OF
 THE PAVEMENT EXCEEDS 4%, THE SHOULDER
 SHALL BE SLOPED SO THAT THE ALGEBRAIC
 DIFFERENCE BETWEEN PAVEMENT AND
 SHOULDER WILL NOT BE GREATER THAN 10%

*** SLOPE SHALL BE THE SAME AS THE
 SUPERELEVATION RATE BUT NOT LESS THAN 6%

13 PROPOSED TYPICAL CROSS SECTION

TRANSITION EMBANKMENT FROM TYPICAL SECTION NO 9
AT STA 196+00 TO TYPICAL SECTION NO 14 AT STA 197+00.

STATION TO STATION
⑨ 196+00 TO 199+22.98 ⑭

- * SEE PLAN AND PROFILE SHEETS FOR SUPERELEVATION (SE) RATES AND FOR TRANSITION LIMITS
- ** WHEN THE SUPERELEVATION RATE OF THE PAVEMENT IS BETWEEN 0% AND 4%, THE SHOULDER SHALL BE SLOPED AT 6%. WHEN THE SUPERELEVATION RATE OF THE PAVEMENT EXCEEDS 4%, THE SHOULDER SHALL BE SLOPED SO THAT THE ALGEBRAIC DIFFERENCE BETWEEN PAVEMENT AND SHOULDER WILL NOT BE GREATER THAN 10%
- *** SLOPE SHALL BE THE SAME AS THE SUPERELEVATION RATE BUT NOT LESS THAN 6%

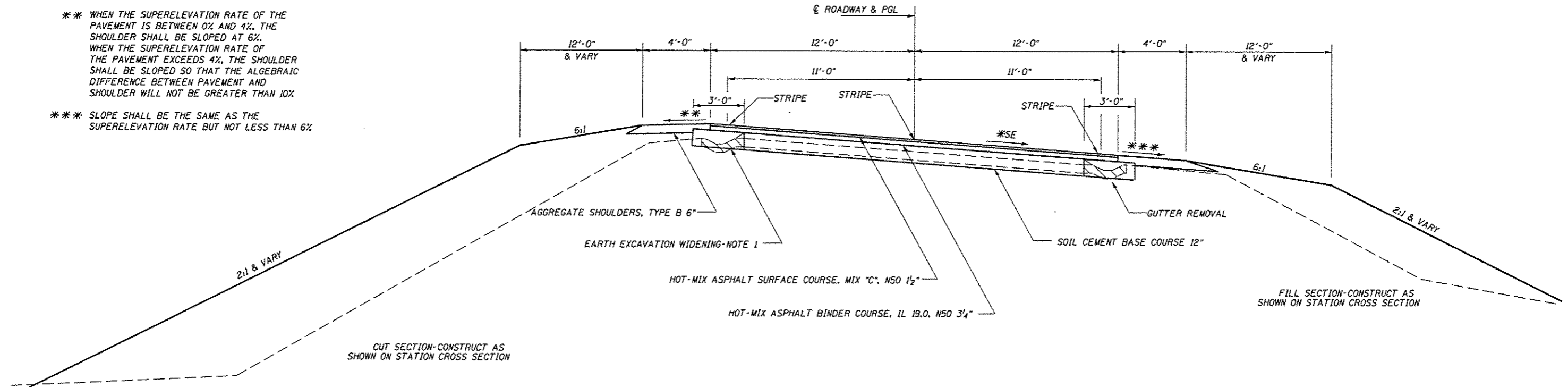

NOTE 1 - SEE SPECIAL PROVISIONS "EARTH EXCAVATION WIDENING", "SOIL-CEMENT BASE COURSE", AND "AGGREGATE BASE COURSE, TYPE B"

14 PROPOSED TYPICAL CROSS SECTION

TRANSITION EMBANKMENT FROM TYPICAL SECTION NO 15
AT STA 200+00 TO TYPICAL SECTION NO 10 AT STA 201+00.

STATION TO STATION
⑬ 199+22.98 TO 201+00 ⑩

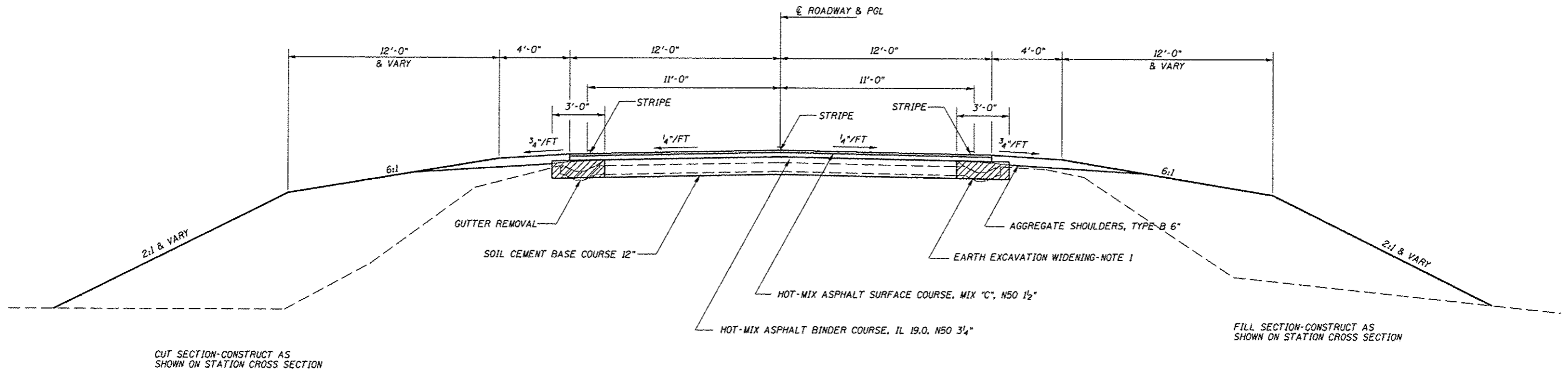

⑮ PROPOSED TYPICAL CROSS SECTION

STATION TO STATION
 ⑦ LT STA 224+50 227+00 ⑦
 ⑦ RT STA 223+00 227+00 ⑦

TRANSITION EMBANKMENT FROM TYPICAL SECTION NO 7 AT RIGHT STA 223+00 TO TYPICAL SECTION NO 16 AT STA 224+00; TRANSITION EMBANKMENT FROM TYPICAL SECTION NO 16 AT STA 226+00 TO TYPICAL SECTION NO 7 AT STA 227+00.

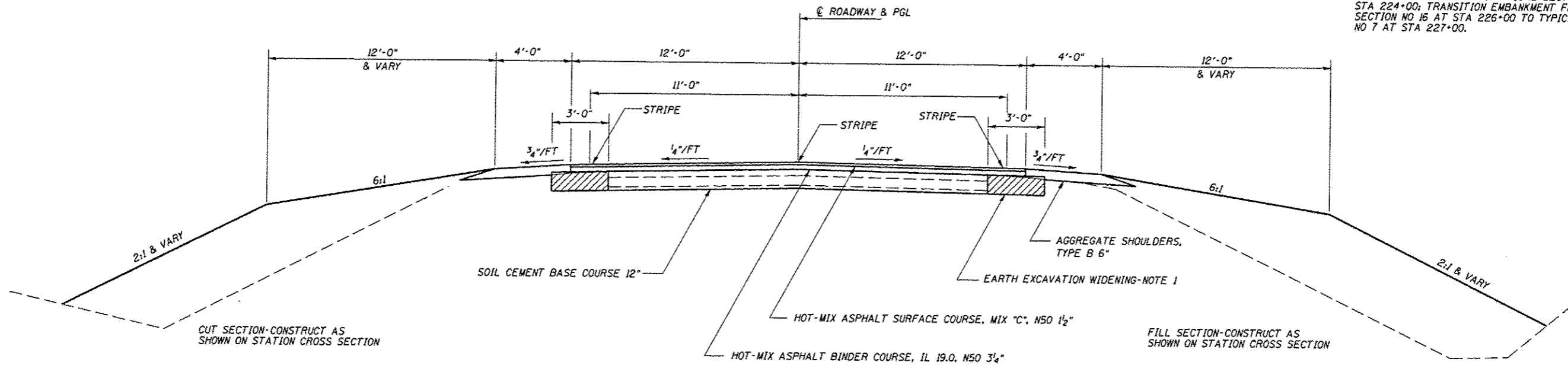

NOTE 1 - SEE SPECIAL PROVISIONS "EARTH EXCAVATION WIDENING", "SOIL-CEMENT BASE COURSE", AND "AGGREGATE BASE COURSE, TYPE B"

PROPOSED TYPICAL CROSS SECTION

STATION TO STATION
 127+50.00 142+47.59
 143+98.71 149+50.00

OMISSION
 STA 142+47.59 TO STA 143+98.71

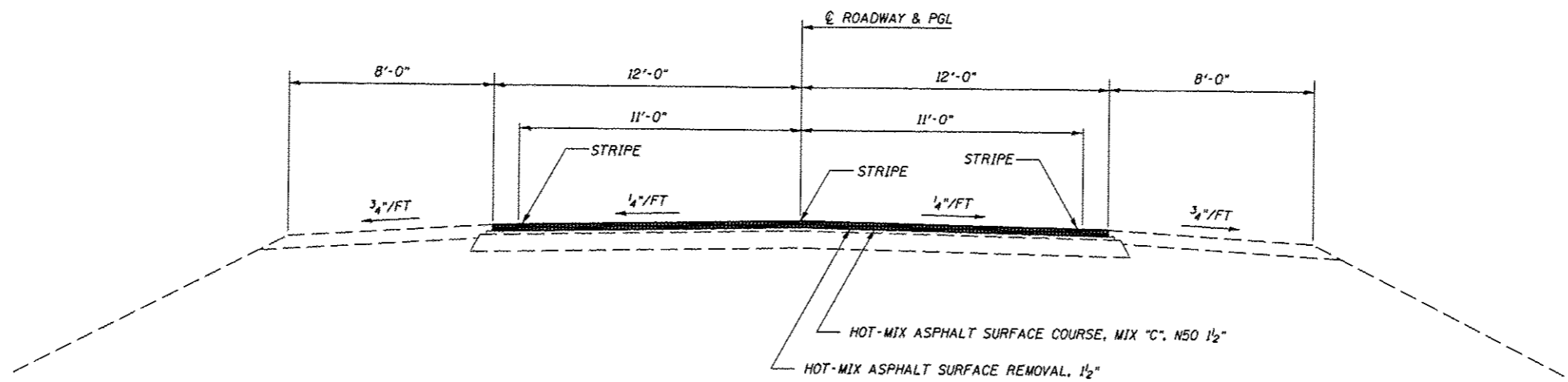

PROPOSED TYPICAL CROSS SECTION

HENRY RD
STA 3+26.81 TO STA 4+62.93

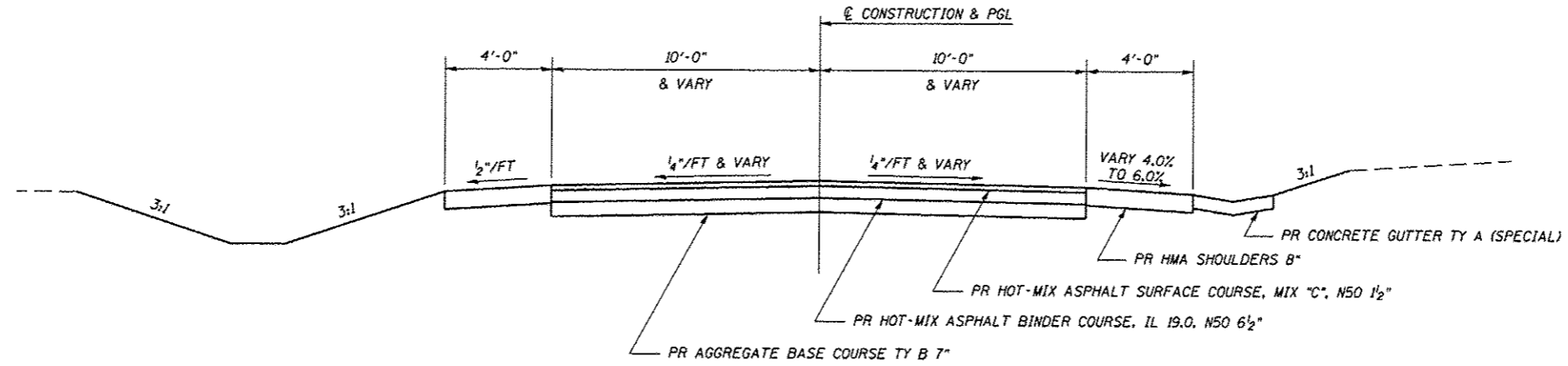

PROPOSED TYPICAL CROSS SECTION

HENRY RD
STA 0+70.00 TO STA 3+26.81
STA 8+41.17 TO STA 9+75.00

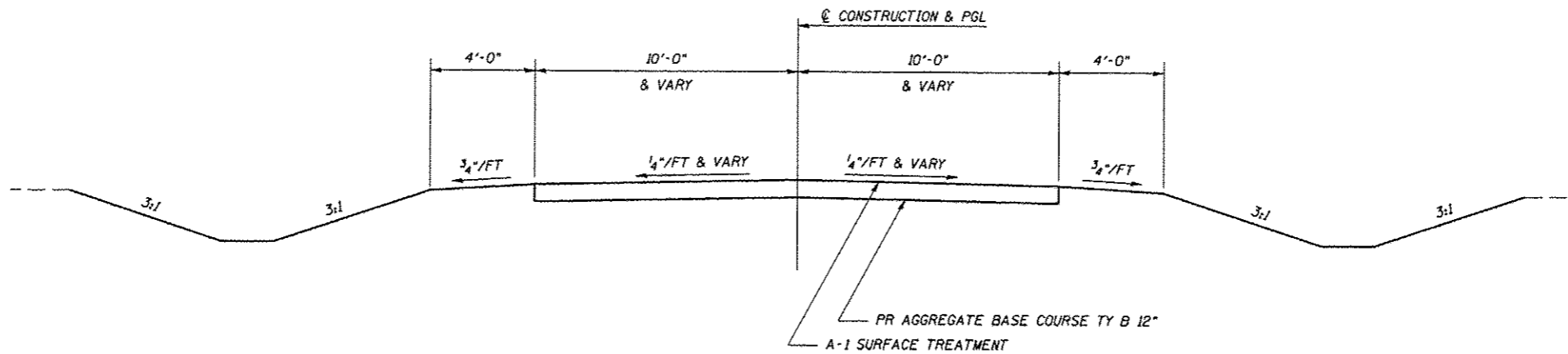

PROPOSED TYPICAL CROSS SECTION

HENRY RD
STA 6+25.00 TO STA 8+41.17

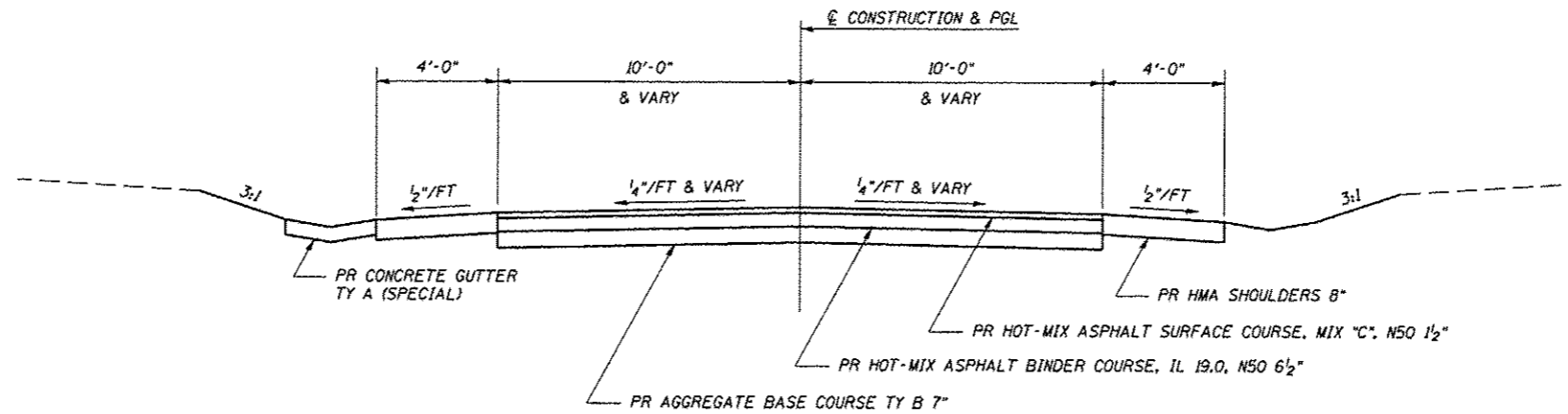

CUT SECTION-CONSTRUCT AS SHOWN ON STATION CROSS SECTION

PROPOSED TYPICAL CROSS SECTION

HENRY RD
STA 4+62.93 TO STA 5+03.29
STA 5+28.14 TO STA 6+25.00
E. LAKE DR
STA 0+12.00 TO STA 11+75.00

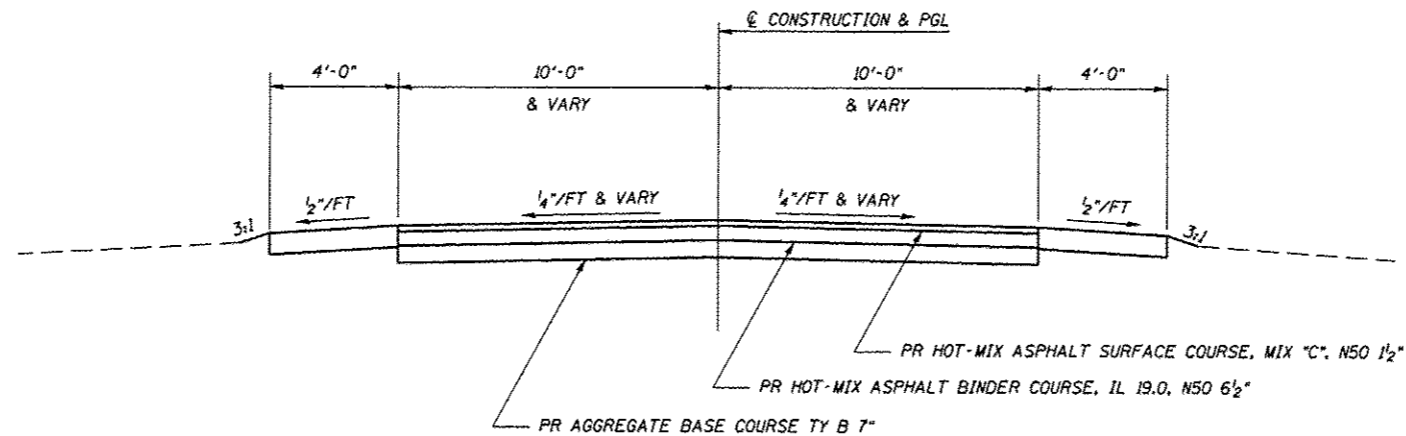

CUT SECTION-CONSTRUCT AS SHOWN ON STATION CROSS SECTION

CONCRETE GUTTER, TYPE A (SPECIAL)

LOCATION	FOOT
CH 12	
LT STA 42+70.40 TO STA 43+35.00	64.60
LT STA 43+65.00 TO STA 45+00.00	135.00
LT STA 204+36.00 TO STA 207+63.00	327.00
RT STA 204+36.00 TO STA 207+63.00	327.00
HENRY RD	
LT STA 6+37.00 TO STA 8+00.00	186.08
RT STA 3+60.84 TO STA 3+73.78	17.92
RT STA 4+01.38 TO STA 4+51.87	58.41
TOTAL	1,116.01

CLASS SI CONCRETE (OUTLET)

LOCATION	TYPE	CU YD
CH 12		
LT STA 42+58.40 TO STA 42+70.40	INLET	1.73
LT STA 43+00.00 TO STA 43+50.00	OUTLET	4.39
LT STA 203+90.50 TO STA 204+36.00	OUTLET	4.06
LT STA 203+63.00 TO STA 204+75.00	INLET	1.73
RT STA 203+90.50 TO STA 204+36.00	OUTLET	4.06
RT STA 203+63.00 TO STA 204+75.00	INLET	1.73
HENRY RD		
LT STA 6+25.00 TO STA 6+37.00	INLET	1.73
LT STA 8+00.00 TO STA 8+52.22	OUTLET	4.62
RT STA 3+07.40 TO STA 3+60.84	OUTLET	4.80
RT STA 3+73.78 TO STA 4+01.35	ENTRANCE	5.00
RT STA 4+51.87 TO STA 4+62.93	INLET	1.73
TOTAL		35.58

PIPE CULVERTS, CLASS A, TYPE 1 15"

LOCATION	FOOT
LT STA 89+36	60
RT STA 101+66	8
TOTAL	60

PIPE CULVERTS, CLASS A, TYPE 1 18"

LOCATION	FOOT
LT STA 36+21	68
LT STA 67+30	48
LT STA 69+05	52
LT STA 73+33	50
LT STA 77+58	54
LT STA 87+52	64
LT STA 101+58	88
LT STA 177+77	56
LT STA 217+17	36
LT STA 224+36	40
RT STA 101+49	74
TOTAL	630

PIPE CULVERTS, CLASS D, TYPE 1 12"

LOCATION	FOOT
HENRY RD	
RT STA 1+00	36
TOTAL	36

CONCRETE COLLAR

LOCATION	SIZE	CONCRETE COLLAR CU YD	REINFORCEMENT BARS POUND	EXPANSION BOLTS 3/4 INCH EACH
LT STA 17+31	CULVERT NO. 1 2'X2'	0.35	20	16
RT STA 17+31	CULVERT NO. 1 2'X2'	0.35	20	16
LT STA 65+37	CULVERT NO. 2 2'X2'	0.26	20	16
LT STA 85+31	CULVERT NO. 3 2'X2'	0.26	20	16
RT STA 85+31	CULVERT NO. 3 2'X2'	0.26	20	16
LT STA 112+34	CULVERT NO. 4 3'X3'	0.37	30	16
LT STA 123+75	CULVERT NO. 5 2'X2'	0.26	20	16
RT STA 123+75	CULVERT NO. 5 2'X2'	0.26	20	16
LT STA 150+59	CULVERT NO. 6 2'X2'	0.28	20	16
RT STA 150+59	CULVERT NO. 6 2'X2'	0.28	20	16
LT STA 152+99	CULVERT NO. 7 2'X2'	0.28	20	16
RT STA 152+99	CULVERT NO. 7 2'X2'	0.28	20	16
LT STA 209+18	30"	0.34	40	4
LT STA 212+41	CULVERT NO. 8 3'X2'	0.34	30	16
RT STA 212+41	CULVERT NO. 11 3'X3'	0.37	30	16
LT STA 219+28	4'X2'	0.41	30	20
RT STA 230+56	CULVERT NO. 9 2'X2'	0.26	20	16
LT STA 233+56	CULVERT NO. 10 2'X2'	0.30	20	16
TOTAL		5.51	420	280

CAST-IN-PLACE BOX CULVERT EXTENSIONS

LOCATION	CONCRETE REMOVAL CU YD	REINFORCEMENT BARS POUNDS	EXPANSION BOLTS 3/4 INCH EACH	CONCRETE BOX CULVERTS CU YD
STA 48+38		20,770	100	124.4
STA 188+27		3,550	32	23.3
STA 198+86		13,170	84	81.6
STA 224+92.0	7.83	9,760	84	58.4
TOTAL	7.83	47,250	300	287.7

PRECAST CONCRETE BOX CULVERT EXTENSIONS ASTM C 1577, DESIGN EARTH COVER LESS THAN 2 FEET

LOCATION	SPECIAL	2'X2'	3'X2'	3'X3'	4'X2'	SKEW
		FOOT	FOOT	FOOT	FOOT	
LT STA 17+31	CULVERT NO. 1	3				32°
RT STA 17+31	CULVERT NO. 1	3				32°
LT STA 65+37	CULVERT NO. 2	3				0°
LT STA 112+34	CULVERT NO. 4			4		0°
LT STA 123+75	CULVERT NO. 5	3				0°
RT STA 123+75	CULVERT NO. 5	3				0°
LT STA 150+59	CULVERT NO. 6	3				13° 15'
RT STA 150+59	CULVERT NO. 6	6				13° 15'
LT STA 152+99	CULVERT NO. 7	4				13° 15'
RT STA 152+99	CULVERT NO. 7	6				13° 15'
LT STA 212+41	CULVERT NO. 8		3			0°
LT STA 219+28					4	0°
RT STA 230+56	CULVERT NO. 9	3				0°
LT STA 233+56	CULVERT NO. 10	9				19°
TOTAL		46	3	4	4	

SEE PRECAST CONCRETE BOX CULVERT EXTENSION DETAILS ON SHEET 69

PRECAST REINFORCED CONCRETE FLARED END SECTIONS 15"

LOCATION	EACH
LT STA 89+36	2
RT STA 101+66	1
TOTAL	3

PIPE CULVERTS, CLASS D, TYPE 1 15"

LOCATION	FOOT
LT STA 17+90	26
LT STA 37+48	24
LT STA 40+24	30
LT STA 71+21	30
LT STA 81+83	52
LT STA 83+47	48
LT STA 118+61	24
LT STA 127+10	34
LT STA 161+00	28
LT STA 166+56	48
LT STA 182+74	52
LT STA 186+50	44
LT STA 203+70	28
LT STA 214+62	24
LT STA 221+75	28
LT STA 222+00	24
RT STA 8+50	32
RT STA 16+32	120
RT STA 38+58	30
RT STA 39+52	44
RT STA 58+00	32
RT STA 67+33	38
RT STA 71+00	26
RT STA 72+00	50
RT STA 77+30	30
RT STA 79+81	58
RT STA 92+67	32
RT STA 93+95	34
RT STA 111+26	28
RT STA 113+05	50
RT STA 114+17	26
RT STA 122+56	30
RT STA 124+00	26
RT STA 124+60	30
RT STA 125+80	52
RT STA 153+60	24
RT STA 161+32	28
RT STA 167+54	48
RT STA 168+65	24
RT STA 175+25	50
RT STA 176+35	32
RT STA 178+45	32
RT STA 180+05	28

PRECAST REINFORCED CONCRETE FLARED END SECTIONS 18"

LOCATION	EACH
LT STA 36+21	2
LT STA 42+28	1
LT STA 42+59	1
LT STA 67+30	2
LT STA 69+05	2
LT STA 73+33	2
LT STA 77+58	2
LT STA 87+52	2
LT STA 101+58	2
RT STA 101+49	2
LT STA 177+77	2
LT STA 217+17	2
LT STA 224+36	2
TOTAL	24

REINFORCED CONCRETE PIPE TEE, 18" PIPE WITH 15" RISER

LOCATION	EACH
RT STA 101+66	1
TOTAL	1

BOX CULVERT END SECTIONS

LOCATION	SIZE	EACH
LT STA 17+31	CULVERT NO. 1 2'X2'	1
RT STA 17+31	CULVERT NO. 1 2'X2'	1
LT STA 65+37	CULVERT NO. 2 2'X2'	1
LT STA 85+31	CULVERT NO. 3 2'X2'	1
RT STA 85+31	CULVERT NO. 3 2'X2'	1
LT STA 112+34	CULVERT NO. 4 3'X3'	1
LT STA 123+75	CULVERT NO. 5 2'X2'	1
RT STA 123+75	CULVERT NO. 5 2'X2'	1
LT STA 150+59	CULVERT NO. 6 2'X2'	1
RT STA 150+59	CULVERT NO. 6 2'X2'	1
LT STA 152+99	CULVERT NO. 7 2'X2'	1
RT STA 152+99	CULVERT NO. 7 2'X2'	1
LT STA 212+41	CULVERT NO. 8 3'X2'	1
RT STA 212+41	CULVERT NO. 11 3'X3'	1
RT STA 230+56	CULVERT NO. 9 2'X2'	1
LT STA 233+56	CULVERT NO. 10 2'X2'	1

HENRY RD		FOOT
LT STA 2+32		44
LT STA 5+60.65		34
RT STA 8+20		44
TOTAL		1,700



JOB # 2184	DESIGNED - NAK	REVISED -
FILE NAME = 2184.sched.dgn	DRAWN - TJD	REVISED -
PLT SCALE = 2,0000' / IN.	CHECKED - NAK	REVISED -
DATE = 7/13/2011	DATE -	REVISED -

MACOUPIN COUNTY
CH 12 IMPROVEMENTS

SCHEDULES OF QUANTITIES

SCALE:	SHEET NO.	OF	SHEETS	STA.	TO	STA.

F.A.S. RTE.	SECTION	COUNTY	TOTAL SHEETS	SHEET NO.
732	01-00079-00-FP	MACOUPIN	141	19
			CONTRACT NO. 93574	

AGGREGATE BASE COURSE, TYPE B

LOCATION	WIDTH	RATE (LB/SQ YD)	TON
CH 12 WIDENING			
LT STA 6+00 TO STA 127+50	10'	410	2,767.50
LT STA 149+50 TO STA 154+50	10'	410	113.89
LT STA 154+55 TO STA 235+75	10'	410	1,849.56
RT STA 6+00 TO STA 127+50	10'	410	2,767.50
RT STA 149+50 TO STA 154+50	10'	410	113.89
RT STA 154+55 TO STA 235+75	10'	410	1,849.56

LOCATION	WIDTH	THICKNESS	TON
CROSS ROAD CULVERTS			
STA 13+19	6'	12"	9.11
STA 167+14	6'	12"	9.11
STA 159+94	6'	12"	9.11
STA 171+75	6'	12"	9.11
STA 202+78	6'	12"	9.11
STA 209+12	6'	12"	9.11

LOCATION	WIDTH	THICKNESS	TON
SIDE ROADS			
E LAKE DR			
STA 10+12 TO STA 11+75	23.33'	7"	243.21
HENRY RD			
STA 0+70 TO STA 3+27	20'	12"	389.97
STA 3+27 TO STA 5+03	23.33'	7"	353.79
STA 5+28 TO STA 8+41	23.33'	7"	496.35
STA 8+41 TO STA 9+75	20'	12"	203.22
TOTAL			11,203.10

AGGREGATE BASE COURSE TYPE B FOR CH 12 WIDENING SHALL BE DONE IN CONJUNCTION WITH EARTH EXCAVATION WIDENING AND PULVERIZING FOR SOIL-CEMENT BASE COURSE. SEE SPECIAL PROVISIONS.

SEE ENTRANCE AND SIDE ROAD SCHEDULES FOR ADDITIONAL QUANTITY.

EARTH EXCAVATION WIDENING

LOCATION	WIDTH	THICKNESS	CJ YD
LT STA 6+00 TO STA 127+50	3'	12"	1,350.00
LT STA 149+50 TO STA 154+50	3'	12"	55.56
LT STA 154+55 TO STA 235+75	3'	12"	902.23
RT STA 6+00 TO STA 127+50	3'	12"	1,350.00
RT STA 149+50 TO STA 154+50	3'	12"	55.56
RT STA 154+55 TO STA 235+75	3'	12"	902.23
TOTAL			4,615.58

GRADING AND SHAPING DITCHES

LOCATION	FOOT
LT STA 202+30	50
TOTAL	50

HOT MIX ASPHALT SURFACE COURSE, MIX "C" N50

LOCATION	WIDTH	THICKNESS	TON
CH 12			
STA 6+00.00 TO STA 142+47.59	24.00'	1.5"	3,057.07
STA 143+98.71 TO STA 154+50.00	24.00'	1.5"	235.49
STA 154+55.00 TO STA 235+75.00	24.00'	1.5"	1,818.88

E LAKE DR			
STA 10+12 TO STA 11+75	20.00'	1.5"	45.45

HENRY RD			
STA 3+27 TO STA 5+03	20.00'	1.5"	68.05
STA 5+28 TO STA 8+41	20.00'	1.5"	93.85
TOTAL			5,318.79

HOT-MIX ASPHALT SURFACE REMOVAL, 1 1/2"

LOCATION	WIDTH	SQ YD
STA 127+50.00 TO STA 142+47.59	24.25'	4,035.17
STA 143+98.71 TO STA 149+50.00	24.25'	1,485.42
TOTAL		5,520.59

HOT MIX ASPHALT BINDER COURSE, IL19.0 N50

LOCATION	WIDTH	THICKNESS	TON
CH 2			
STA 6+00 TO STA 88+00	24.63'	2.25"	2,827.53
STA 88+00 TO STA 127+50	24.79'	3.25"	1,980.18
STA 149+50 TO STA 154+50	24.79'	3.25"	250.66
STA 154+55 TO STA 235+75	24.79'	3.25"	4,070.63

E LAKE DR			
STA 10+12 TO STA 11+75	21.33'	6.50"	196.95

HENRY RD			
STA 3+27 TO STA 5+03	21.33'	6.50"	301.61
STA 5+28 TO STA 8+41	21.33'	6.50"	417.77
TOTAL			10,045.33

BITUMINOUS MATERIALS (PRIME COAT)

LOCATION	WIDTH	RATE (GAL/SQ YD)	GALLON
CH 12			
STA 6+00.00 TO STA 88+00.00	24.63'	0.10	2,244.07
STA 88+00.00 TO STA 127+50.00	24.79'	0.10	1,088.01
STA 127+50.00 TO STA 142+47.59	24.25'	0.10	403.52
STA 143+98.71 TO STA 149+50.00	24.25'	0.10	148.55
STA 149+50.00 TO STA 154+50.00	24.79'	0.10	137.73
STA 154+55.00 TO STA 235+75.00	24.79'	0.10	2,236.61

E LAKE DR			
STA 10+12 TO STA 11+75	20.00'	0.35	189.38

HENRY RD			
STA 3+27 TO STA 5+03	20.00'	0.35	283.54
STA 5+28 TO STA 8+41	20.00'	0.35	391.04
TOTAL			7,122.45

AGGREGATE (PRIME COAT)

LOCATION	WIDTH	RATE (LB/SQ YD)	TON
CH 12			
STA 6+00.00 TO STA 88+00.00	24.63'	4	44.89
STA 88+00.00 TO STA 127+50.00	24.79'	4	21.77
STA 127+50.00 TO STA 142+47.59	24.25'	4	8.08
STA 143+98.71 TO STA 149+50.00	24.25'	4	2.98
STA 149+50.00 TO STA 154+50.00	24.79'	4	2.76
STA 154+55.00 TO STA 235+75.00	24.79'	4	44.74

E LAKE DR			
STA 10+12.00 TO STA 11+75.00	20.00'	4	1.09

HENRY RD			
STA 3+28.81 TO STA 5+03.24	20.00'	4	1.63
STA 5+28.15 TO STA 8+41.17	20.00'	4	2.24
TOTAL			130.18

SEAL COAT

LOCATION	WIDTH	BITUMINOUS MATERIALS (PRIME COAT) RATE (GAL/SQ YD)	GALLON	BITUMINOUS MATERIALS (COVER AND SEAL) SEAL COAT GAL/SQ YD	GALLON	SEAL COAT AGGREGATE TON
CH 12						
STA 6+00 TO STA 127+50	26	0.10	3,510	0.40	14,040	438.75
STA 149+50 TO STA 154+50	26	0.10	144	0.40	578	18.06
STA 154+55 TO STA 235+78	26	0.10	2,347	0.40	9,387	293.33
HENRY RD						
STA 0+70 TO STA 3+27	20	0.35	192	0.40	219	6.84
STA 8+41 TO STA 9+75	20	0.35	99	0.40	113	3.53
TOTAL			6,292		24,336	760.51

SOIL-CEMENT BASE COURSE 12"

LOCATION	WIDTH	PROCESSING SOIL-CEMENT BASE COURSE 12 SQ YD	CEMENT 100 WT
CH 12			
STA 6+00 TO STA 127+50	26	35,100.00	43,278.30
STA 149+50 TO STA 154+50	26	1,444.44	1,780.99
STA 154+55 TO STA 235+78	26	23,466.44	28,934.12
TOTAL		60,010.88	73,993.41

PORTLAND CEMENT CONCRETE DRIVEWAY PAVEMENT, 8 INCH

LOCATION	SQ YD
LT STA 89+36.00	136.00



JOB # 2184
 FILE NAME = 2184sched.dgn
 PLOT SCALE = 2.0000' / IN.
 PLOT DATE = 12/9/2013

DESIGNED - NAK
 DRAWN - TJD
 CHECKED - NAK
 DATE - 7/13/2011

REVISED -
 REVISED -
 REVISED -
 REVISED -

MACOUPIN COUNTY
 CH 12 IMPROVEMENTS

SCHEDULES OF QUANTITIES

SCALE: SHEET NO. OF SHEETS STA. TO STA. FEDERAL ROAD DIST. NO. [ILLINOIS] FED. AID PROJECT

F.A.S. RTE.	SECTION	COUNTY	TOTAL SHEETS	SHEET NO.
732	01-00079-00-FP	MACOUPIN	141	21
CONTRACT NO. 93574				

BEGIN CH 12 IMPROVEMENT
STA 6+00

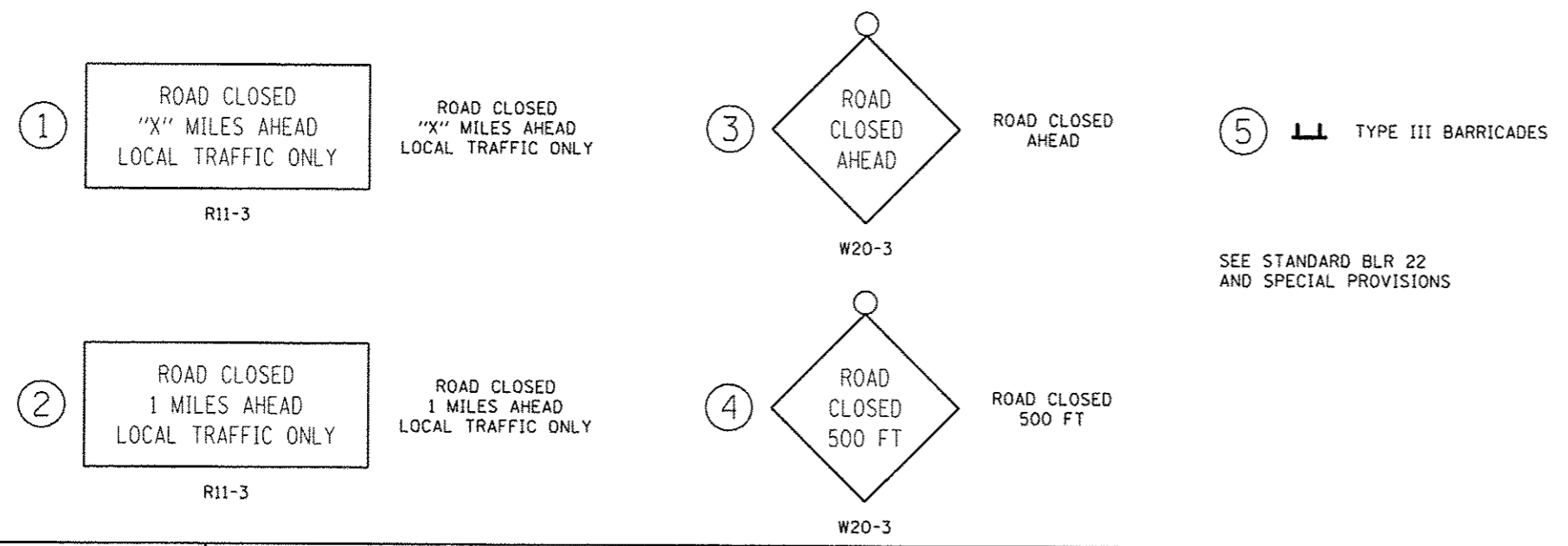
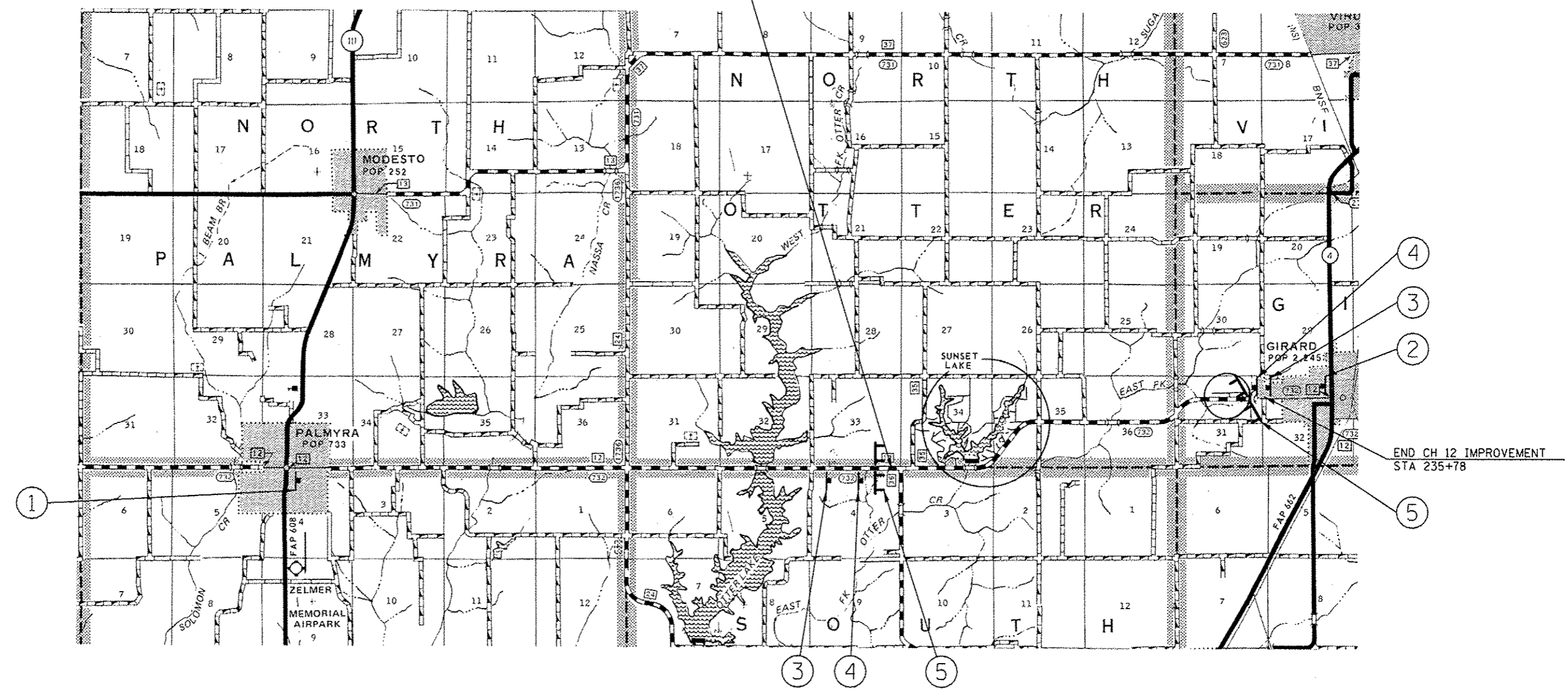

CEC Cummins Engineering Corporation Civil and Structural Engineering	JOB • 2184	DESIGNED -	REVISED -	MACOUPIN COUNTY CH 12 IMPROVEMENTS	SIGN LOCATION MAP	F.A.S. RTE.	SECTION	COUNTY	TOTAL SHEETS	SHEET NO.
	FILE NAME • 2184SignLocationMap.dgn	CHECKED -	REVISED -			732	01-00079-00-FP	MACOUPIN	141	23
	PLOT SCALE • 2.0000" / 1"	DRAWN -	REVISED -			CONTRACT NO. 93574		ILLINOIS FED. AID PROJECT		
	PLOT DATE • 11/21/2013	CHECKED -	REVISED -			SHEET NO. OF SHEETS				

STA 17+31 ASTM C 1577
PR 2'x2' BOX CULVERT EXTENSION
SKEW 32° RH DESIGN FILL < 2'
CONCRETE COLLAR
3' PRECAST BOX CULVERT 2'x2'
PRECAST END SECTION

PROP PIPE CULVERTS
CL D TY 15"x120"
USFL 27.4' RT STA 16+17.4 650.8
DSFL 31.6' RT STA 17+37.8 648.0
INLETS TYPE A, TYPE B GRATE
29.95' RT STA 16+90
E GRATE 651.0
E 15' 649.11

PROP PIPE CULVERT
CL D TY 15"x26'

STA 20+52
EXIST 2'x2' BOX CULVERT

PROP PIPE CULVERT CL A
TY 1 24"x54' WITH
STD 542301 END SECTIONS
USFL 30.15' LT STA 13+06.10 649.74
DSFL 30.60' RT STA 13+32.50 649.19

STA 17+31 ASTM C 1577
PR 2'x2' BOX CULVERT EXTENSION
SKEW 32° RH DESIGN FILL < 2'
CONCRETE COLLAR
3' PRECAST BOX CULVERT 2'x2'
PRECAST END SECTION

STONE RIPRAP CL A 3
(SPECIAL) 26"x16.5"

DATE	
BY	
REVISION	
NO.	
PLAN	
DATE	
BY	
REVISION	
NO.	
NOTE BOOK	
NO.	
NO. OF PAGES CHECKED	
NO.	
FILE NAME	

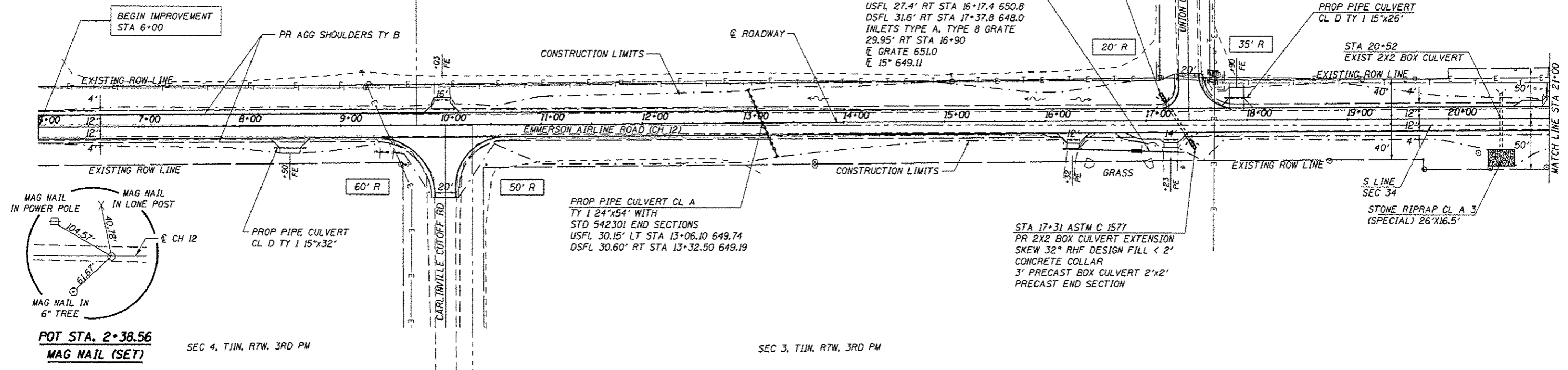

POT STA. 2+38.56
MAG NAIL (SET)

SEC 4, T11N, R7W, 3RD PM

SEC 3, T11N, R7W, 3RD PM

DATE	
BY	
REVISION	
NO.	
PROFILE	
DATE	
BY	
REVISION	
NO.	
NOTE BOOK	
NO.	
NO. OF PAGES CHECKED	
NO.	
FILE NAME	

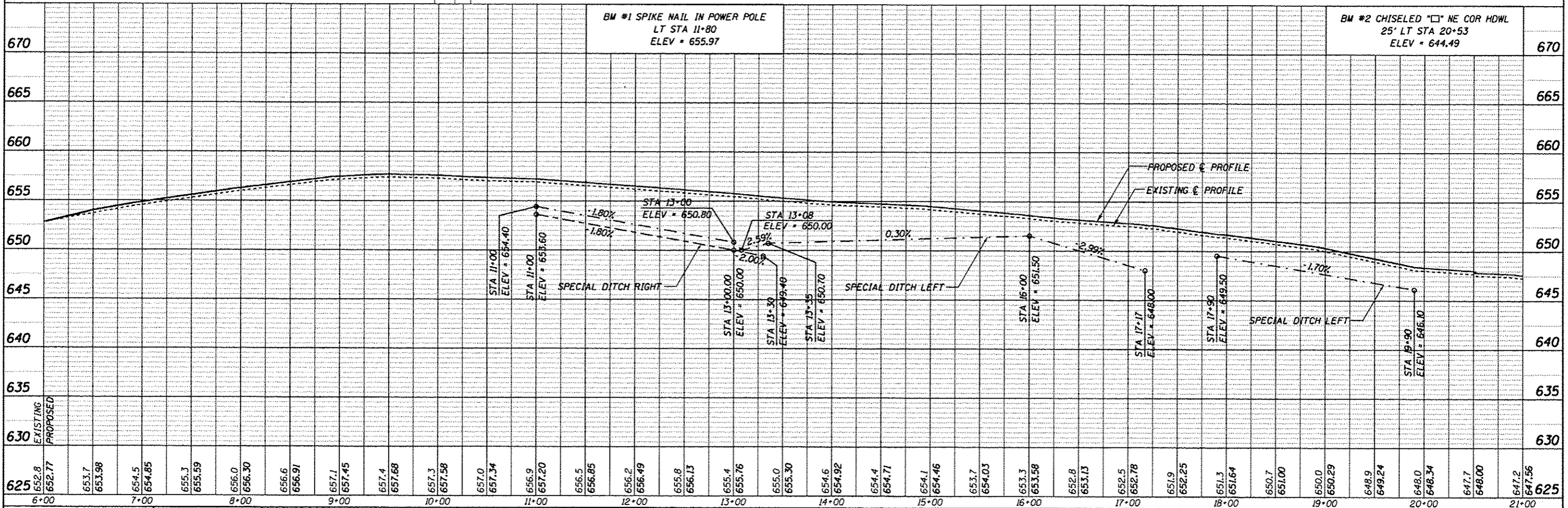

CEC Cummins Engineering Corporation
Civil and Structural Engineering

JOB # 2184
FILE NAME = 2184p&g.dgn
PLOT SCALE = 1/8" = 1'-0"
PLOT DATE = 12/5/2013

DESIGNED - NAK
DRAWN - TJO
CHECKED - NAK
DATE - 5/31/2011

REVISED -
REVISED -
REVISED -
REVISED -

**MACOUPIN COUNTY
CH 12 IMPROVEMENTS**

PLAN & PROFILE

SCALE: SHEET NO. OF SHEETS STA. 6+00 TO STA. 21+00

F.A.S. RTE.	SECTION	COUNTY	TOTAL SHEETS	SHEET NO.
732	01-00079-00-FP	MACOUPIN	141	24
FED. ROAD DIST. NO.		ILLINOIS FED. AID PROJECT		CONTRACT NO. 93574

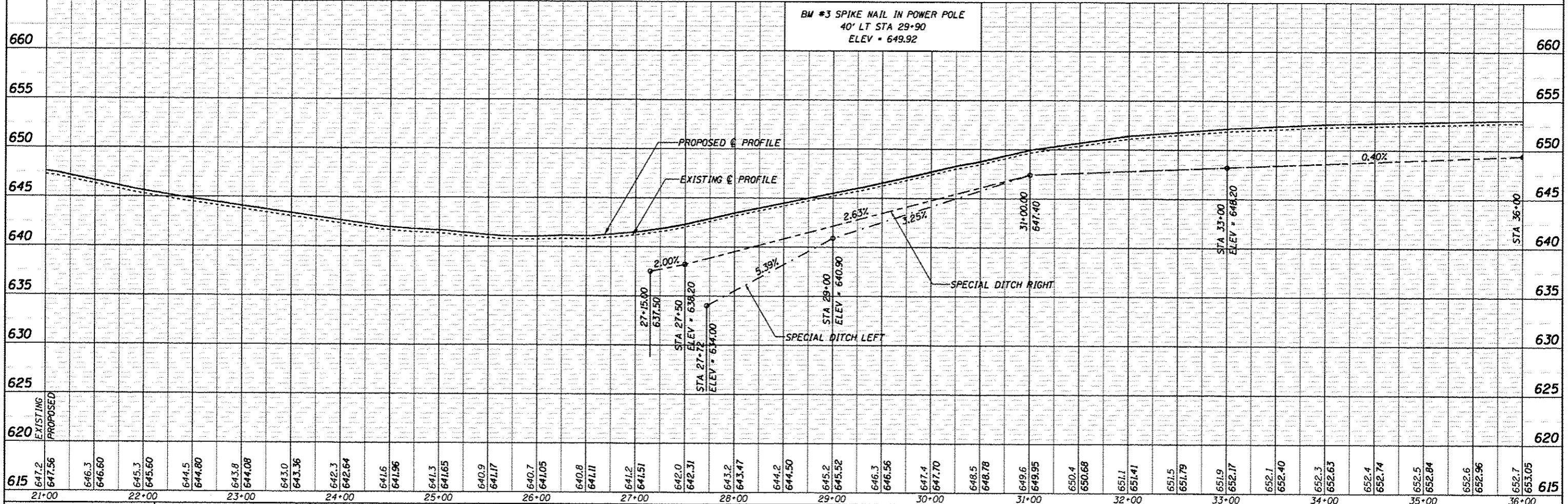
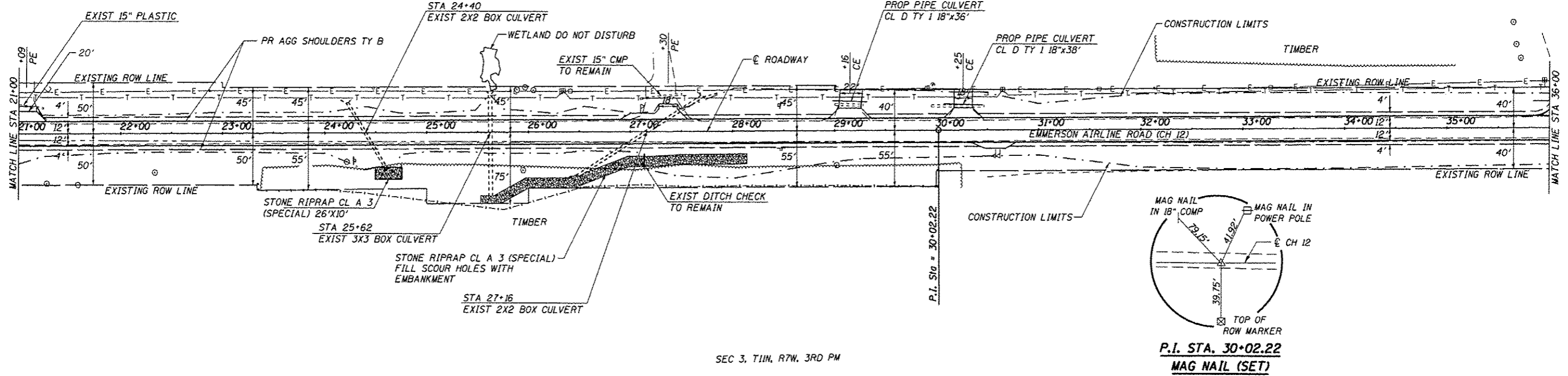

CEC Cummins Engineering Corporation Civil and Structural Engineering	JOB = 2184	DESIGNED - NAK	REVISED -	MACOUPIN COUNTY CH 12 IMPROVEMENTS	PLAN & PROFILE		F.A.S. RTE. 732 SECTION 01-00079-00-FP COUNTY MACOUPIN TOTAL SHEETS 141 SHEET NO. 25 CONTRACT NO. 93574
	FILE NAME = 2184p.dgn PLOT SCALE = 1/800.000" / 1" PLOT DATE = 12/5/2013	DRAWN - TJD CHECKED - NAK DATE - 5/31/2011	REVISED - REVISED - REVISED - REVISED -		SCALE: SHEET NO. OF SHEETS STA. 21+00 TO STA. 36+00	FEDERAL ROAD DIST. NO. ILLINOIS FED. AID PROJECT	

DATE	
BY	
APPROVED	
PLANNED	
NOTED	
FILED	
NO.	

DATE	
BY	
APPROVED	
PLANNED	
NOTED	
FILED	
NO.	

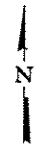

EXISTING STRUCTURE NO. 059-5004
 ORIGINALLY BUILT AS STA 38+37
 DOUBLE 12' SPAN x 8' RISE
 REINFORCED CONCRETE BOX CULVERT
 72.5' O-O HEADWALLS
 0° SKEW

SEC 34, T12N, R7W, 3RD PM

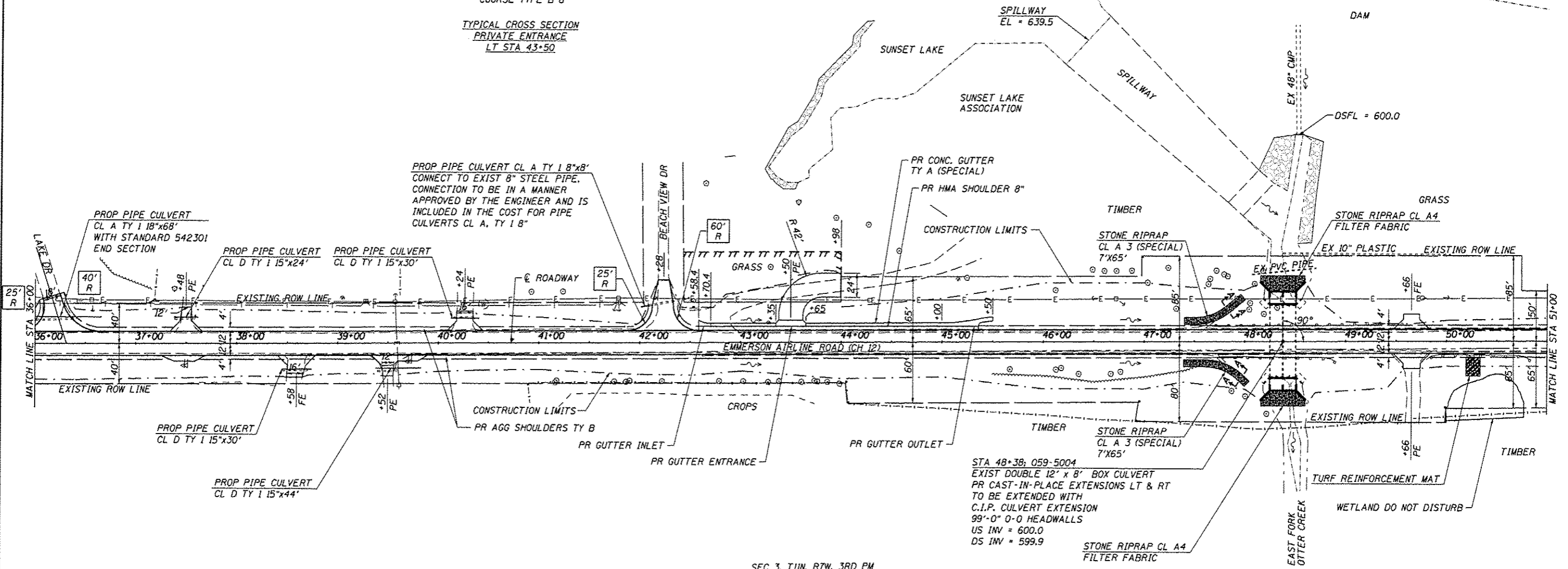
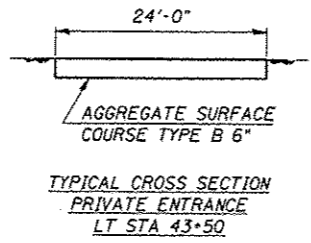

SEC 3, T11N, R7W, 3RD PM

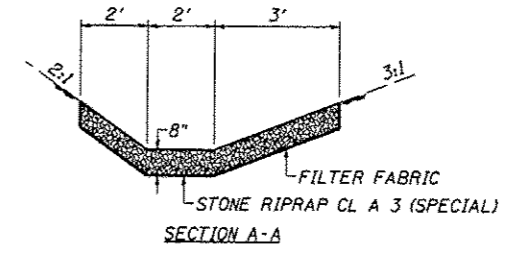

BM #4 SPIKE NAIL IN POWER POLE
 43' LT STA 36+56
 ELEV = 652.94

BM #5 SPIKE NAIL IN POWER POLE
 41' LT STA 44+29
 ELEV = 651.66



JOB # 2184	DESIGNED - NAK	REVISED -
FILE NAME = 2184sp.dgn	DRAWN - TJD	REVISED -
PLOT SCALE = 1/8" = 1'-0"	CHECKED - NAK	REVISED -
PLOT DATE = 12/5/2013	DATE - 5/31/2011	REVISED -

**MACOUPIN COUNTY
 CH 12 IMPROVEMENTS**

SCALE:	SHEET NO. OF SHEETS	STA. 36+00 TO STA. 51+00
--------	---------------------	--------------------------

F.A.S. RTE.	SECTION	COUNTY	TOTAL SHEETS	SHEET NO.
732	01-00079-00-FP	MACOUPIN	141	26
FED. ROAD DIST. NO. ILLINOIS FED. AID PROJECT			CONTRACT NO. 93574	

PLAN	DATE
BY	
REVIEWED	
ALLOTTMENT CHECKED	
RT. OF WAY CHECKED	
NO. OF	
ADD FILE NAME	

PROFILE	DATE
BY	
REVIEWED	
PLOTTED	
UPDATES CHECKED	
STRUCTURE NOTATION CHECKED	
NO.	

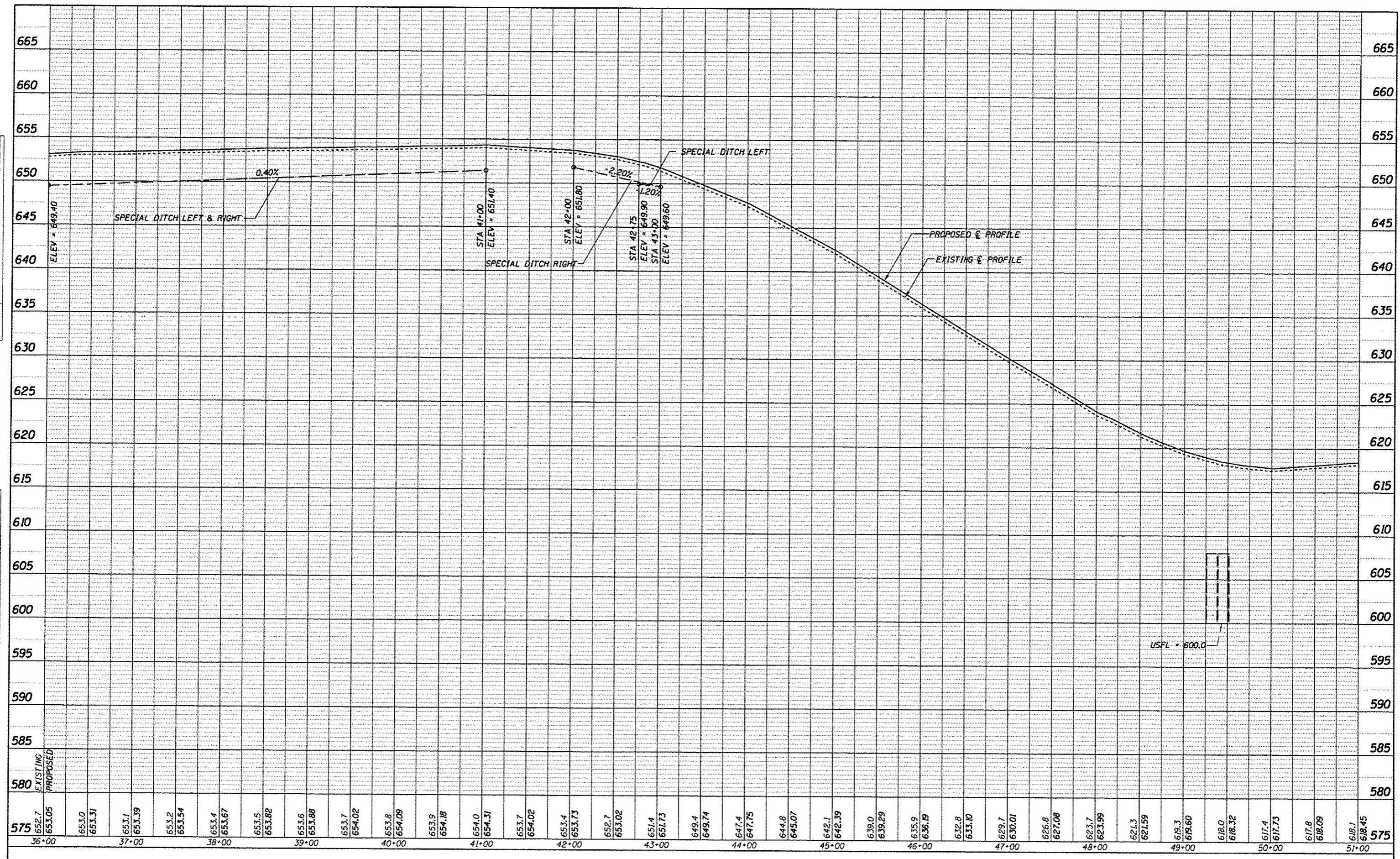

CEC Cummins Engineering Corporation Civil and Structural Engineering	JOB # 2184 FILE NAME = 2184p&p.dgn PLOT SCALE = 1/80,000" = 1" PLOT DATE = 11/21/2013	DESIGNED - NAK DRAWN - TJD CHECKED - NAK DATE - 5/31/2011	REVISED - REVISED - REVISED - REVISED -	MACOUPIN COUNTY CH 12 IMPROVEMENTS	PROFILE SCALE: SHEET NO. OF SHEETS STA. 36+00 TO STA. 51+00	F.A.S. RTE. 732 SECTION 01-00079-00-FP COUNTY MACOUPIN TOTAL SHEETS 141 SHEET NO. 27 CONTRACT NO. 93574 FED. ROAD DIST. NO. [ILLINOIS] FED. AID PROJECT
--	--	--	--	---	---	---

CURVE DATA

PI = STA 60+21.31
 Δ = 51° 23' 5"
 D = 5° 00'
 R = 1145.92
 T = 551.34
 L = 1027.76
 E = 125.74
 PC = STA 54+69.97
 PT = STA 64+97.73
 SE = 7.5%
 SE = TRANSITION LENGTH 198'
 ATTAIN FROM STA 53+21.47 TO STA 55+19.47
 REMOVE FROM STA 64+47.73 TO STA 66+45.73

STA 65+37 ASTM C 1577
 PR 2X2 BOX CULVERT EXTENSION
 CONCRETE COLLAR
 3' PRECAST BOX CULVERT 2'x2'
 PRECAST END SECTION
 0° SKEW DESIGN FILL < 2'

DATE	
BY	
REVISIONS	
NO.	
DATE	
BY	
REVISIONS	
NO.	
DATE	
BY	
REVISIONS	
NO.	

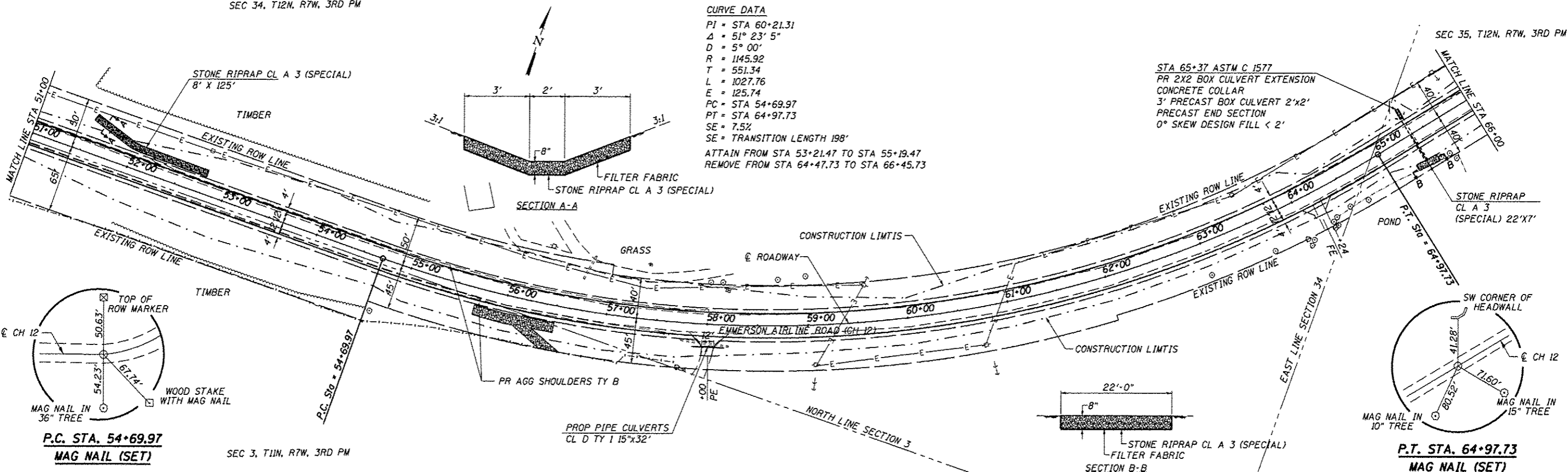

P.C. STA. 54+69.97
 MAG NAIL (SET)

SEC 3, T11N, R7W, 3RD PM

P.T. STA. 64+97.73
 MAG NAIL (SET)

DATE	
BY	
REVISIONS	
NO.	
DATE	
BY	
REVISIONS	
NO.	
DATE	
BY	
REVISIONS	
NO.	

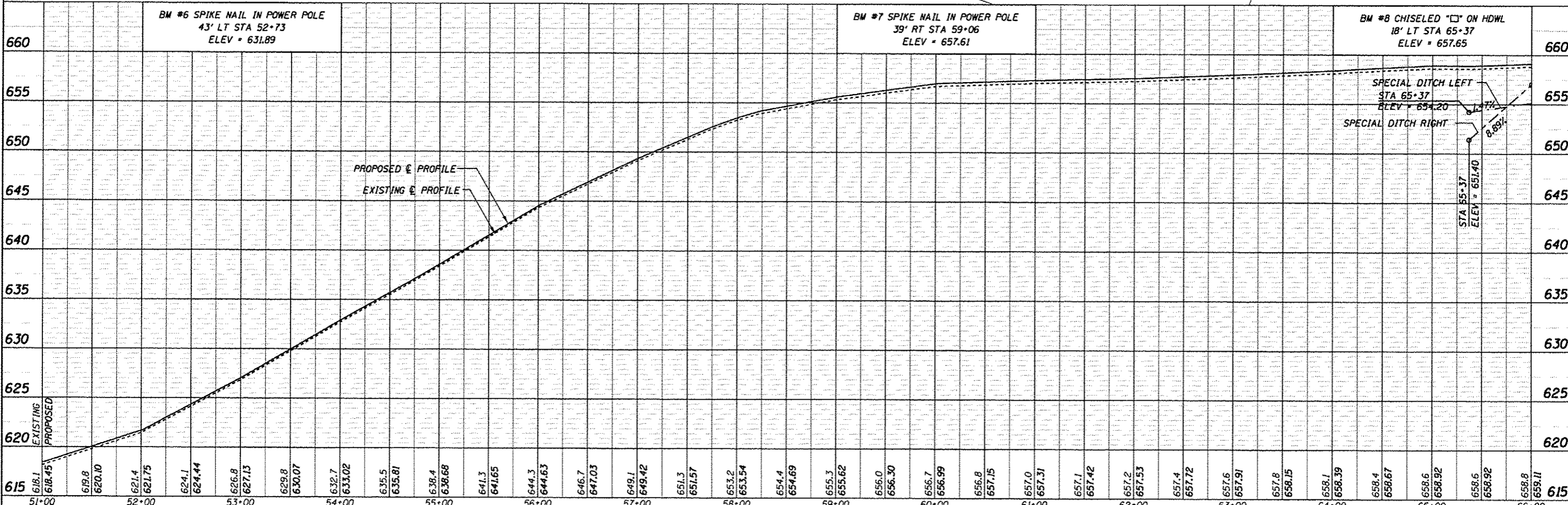

CEC Cummins Engineering Corporation Civil and Structural Engineering	JOB # 2184 FILE NAME = 2184p&p.dgn PLOT SCALE = 1/8" = 100'-0" / IN. PLOT DATE = 12/5/2013	DESIGNED - NAK DRAWN - TJD CHECKED - NAK DATE - 5/31/2011	REVISED - REVISED - REVISED - REVISED -	MACOUPIN COUNTY CH 12 IMPROVEMENTS	PLAN & PROFILE SCALE: 1" = 40'-0" SHEET NO. OF SHEETS STA. 51+00 TO STA. 66+00	F.A.S. RTE. 732 SECTION 01-00079-00-FP COUNTY MACOUPIN TOTAL SHEETS 141 SHEET NO. 28 CONTRACT NO. 93574
--	---	--	--	---------------------------------------	--	--

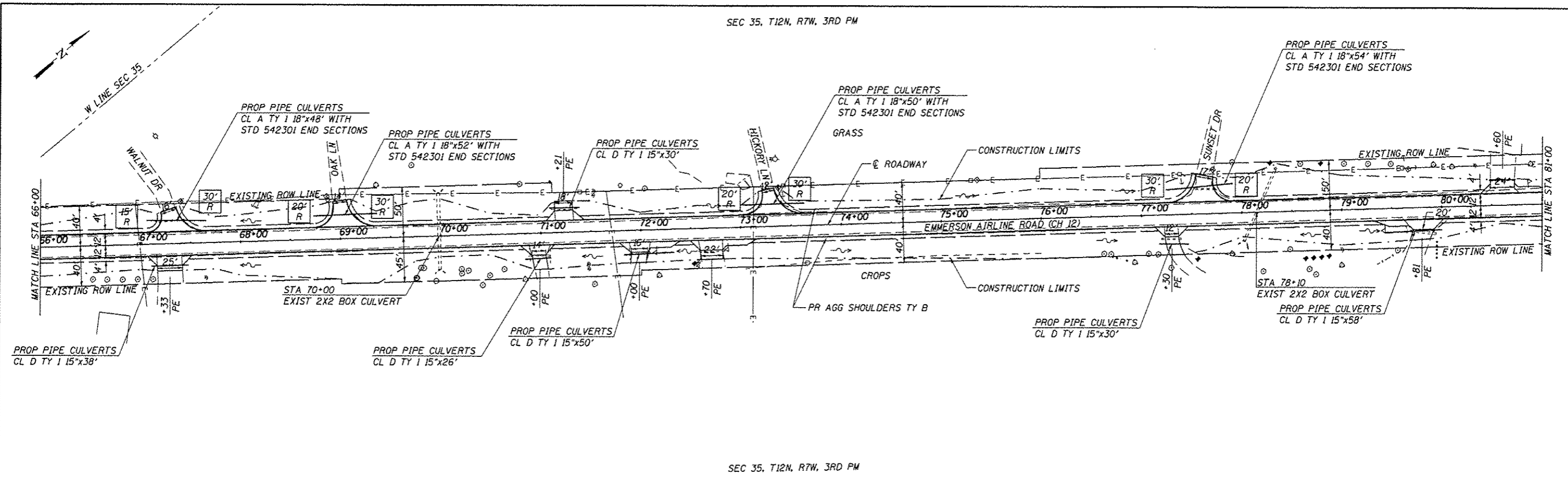

DATE	
BY	
PLAN	
NO.	
NOTE BOOK	
NO.	
DATE	
BY	
PROFILE	
NO.	
NOTE BOOK	
NO.	
DATE	
BY	

DATE	
BY	
PROFILE	
NO.	
NOTE BOOK	
NO.	
DATE	
BY	

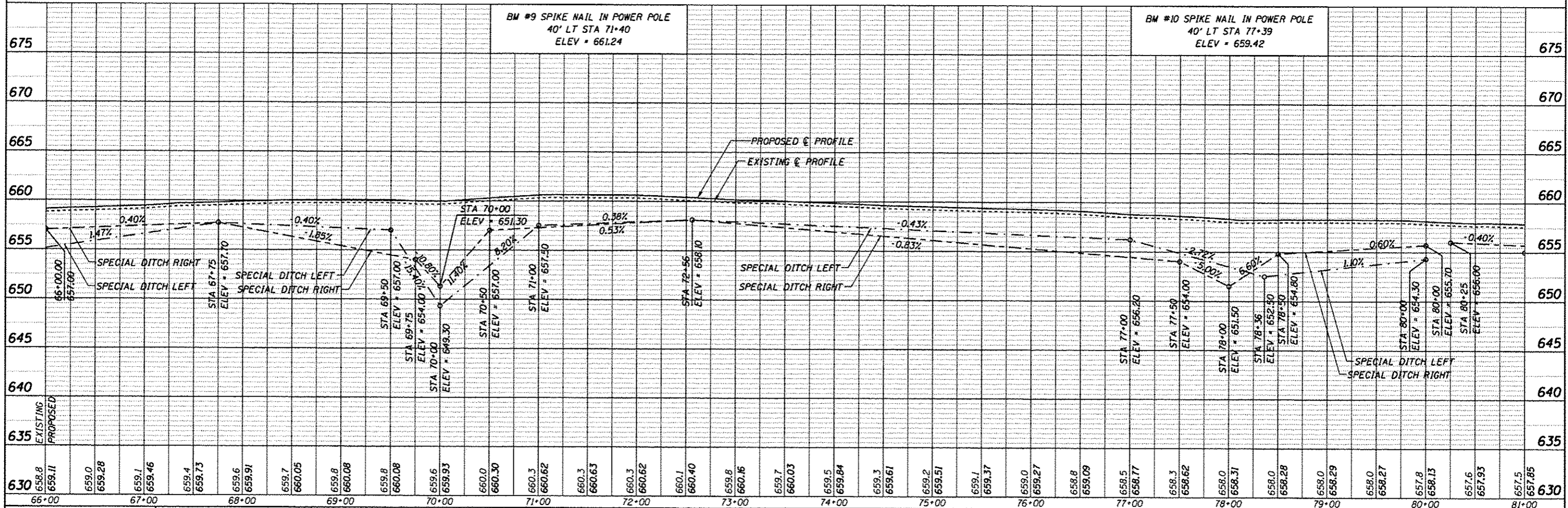

CEC Cummins Engineering Corporation
Civil and Structural Engineering

JOB #	2184
FILE NAME	2184p&g.dgn
PLOT SCALE	1/8" = 1'-0"
PLOT DATE	12/5/2013
DESIGNED	NAK
DRAWN	TJD
CHECKED	NAK
DATE	5/31/2011
REVISED	
REVISED	
REVISED	
REVISED	

MACOUPIN COUNTY CH 12 IMPROVEMENTS

PLAN & PROFILE	
SCALE:	
SHEET NO.	OF SHEETS
STA. 66+00	TO STA. 81+00

F.A.S. RTE.	SECTION	COUNTY	TOTAL SHEETS	SHEET NO.
732	01-00079-00-FP	MACOUPIN	141	29
FED. ROAD DIST. NO.		CONTRACT NO. 93574		
ILLINOIS		FED. AID PROJECT		

SEC 35, T12N, R7W, 3RD PM

SUNSET LAKE ASSOCIATION

GARY L. HAYS

DATE
BY
CHECKED
NOTED
NO.

DATE
BY
CHECKED
NOTED
NO.

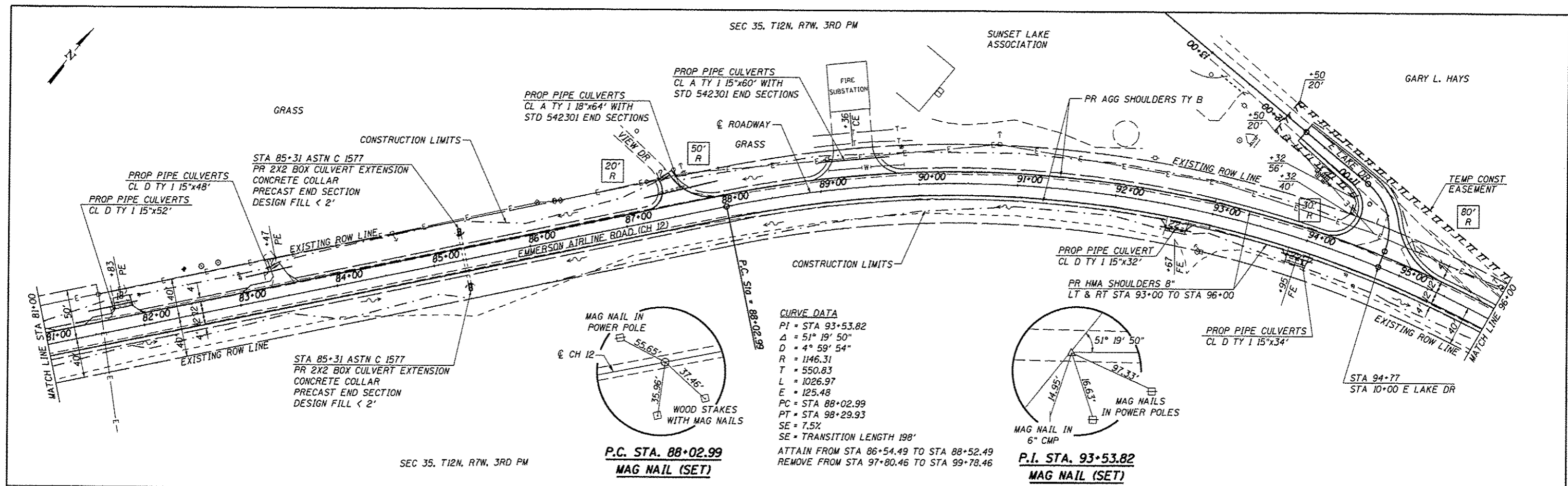

SEC 35, T12N, R7W, 3RD PM

P.C. STA. 88+02.99
MAG NAIL (SET)

P.I. STA. 93+53.82
MAG NAIL (SET)

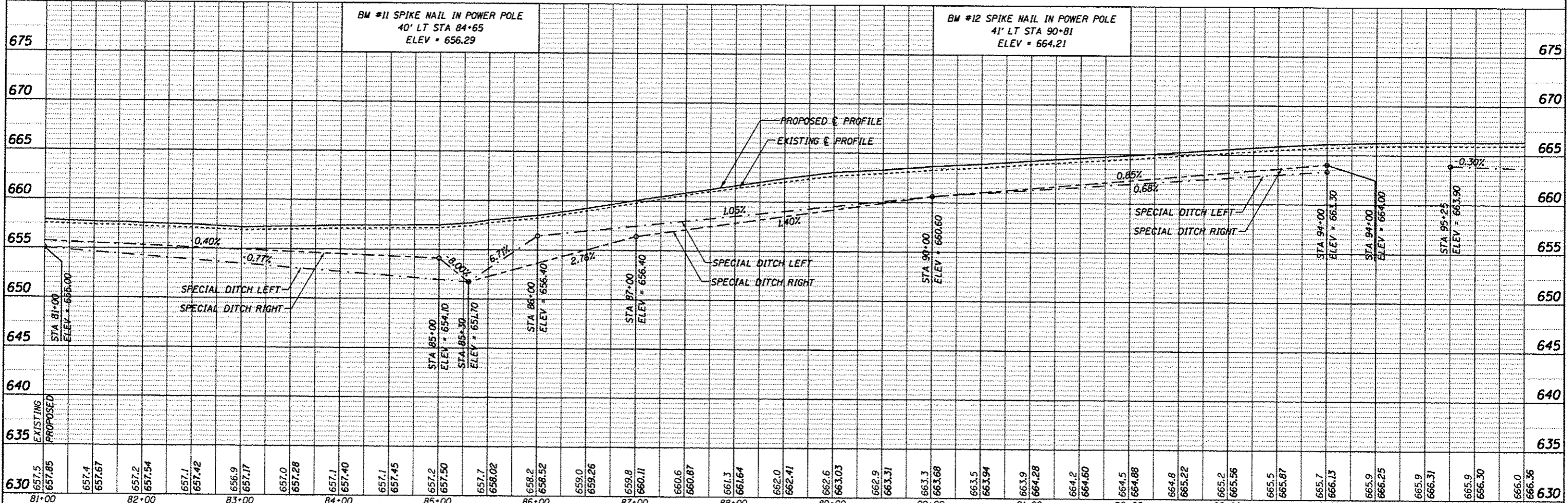

CEC Cummins Engineering Corporation Civil and Structural Engineering	JOB = 2184	DESIGNED - NAK	REVISED -	MACOUPIN COUNTY CH 12 IMPROVEMENTS	PLAN & PROFILE	F.A.S. RTE.	SECTION	COUNTY	TOTAL SHEETS	SHEET NO.	
	FILE NAME = 2184p&p.dgn	DRAWN - TJD	REVISED -			732	01-00079-00-FP	MACOUPIN	141	30	
	PLOT SCALE = 100.000' / IN.	CHECKED - NAK	REVISED -			CONTRACT NO. 93574					
	PLOT DATE = 11/21/2013	DATE - 5/31/2011	REVISED -			FED. ROAD DIST. NO. [ILLINOIS] FED. AID PROJECT					

DATE	
BY	
REVISIONS	
NO.	
DATE	
BY	
REVISIONS	
NO.	
DATE	
BY	
REVISIONS	
NO.	
DATE	
BY	
REVISIONS	
NO.	
DATE	
BY	
REVISIONS	
NO.	

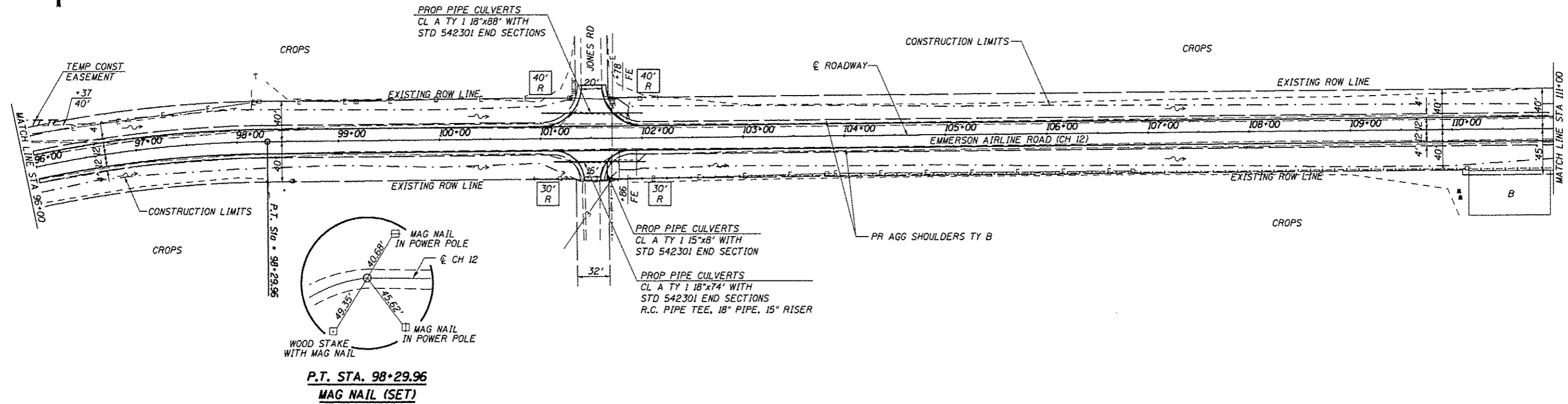

DATE	
BY	
REVISIONS	
NO.	
DATE	
BY	
REVISIONS	
NO.	
DATE	
BY	
REVISIONS	
NO.	
DATE	
BY	
REVISIONS	
NO.	

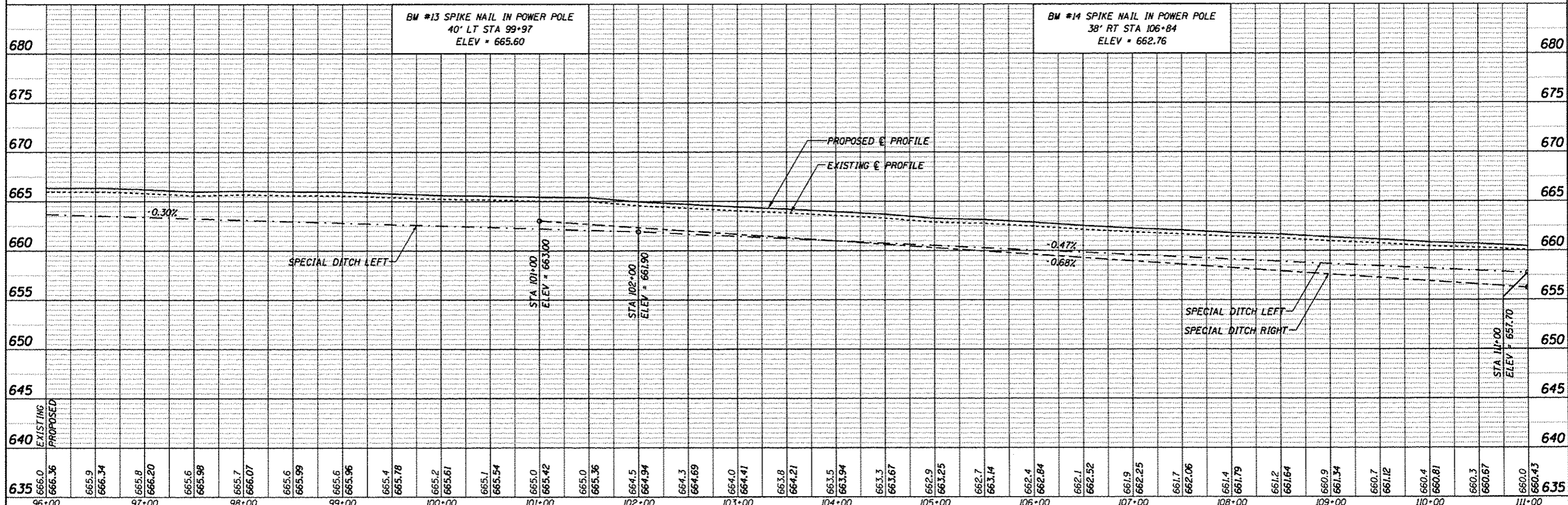

CEC Cummins Engineering Corporation
Civil and Structural Engineering

JOB # 2184
FILE NAME # 2184p&o.dgn
PLOT SCALE # 1/8"=1'-0"
PLOT DATE # 11/21/2013

DESIGNED - NAK
DRAWN - TJD
CHECKED - NAK
DATE - 5/31/2011

REVISED -
REVISED -
REVISED -
REVISED -

**MACOUPIN COUNTY
CH 12 IMPROVEMENTS**

PLAN & PROFILE

SCALE: SHEET NO. OF SHEETS STA. 96+00 TO STA. 111+00

F.A.S. RTE. 732	SECTION 01-00079-00-FP	COUNTY MACOUPIN	TOTAL SHEETS 141	SHEET NO. 31
FED. ROAD DIST. NO. ILLINOIS FED. AID PROJECT			CONTRACT NO. 93574	

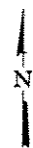

DATE	
BY	
REVISIONS	
NO.	
DESCRIPTION	
DATE	
BY	
REVISIONS	
NO.	
DESCRIPTION	
DATE	
BY	
REVISIONS	
NO.	
DESCRIPTION	

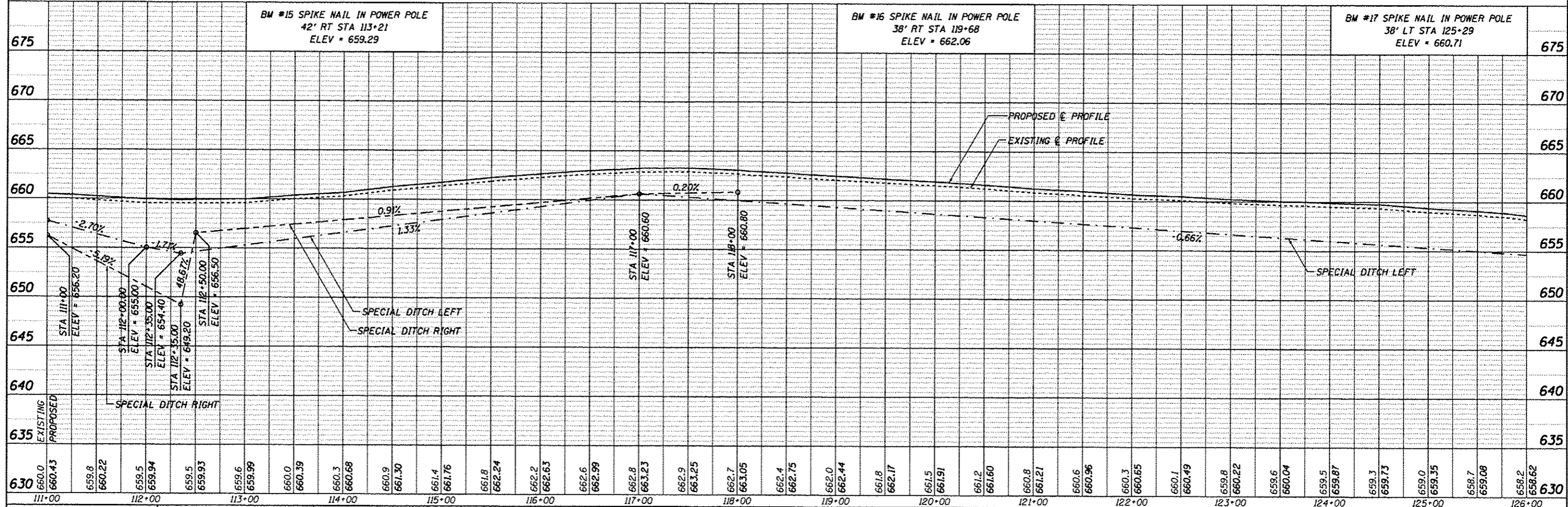
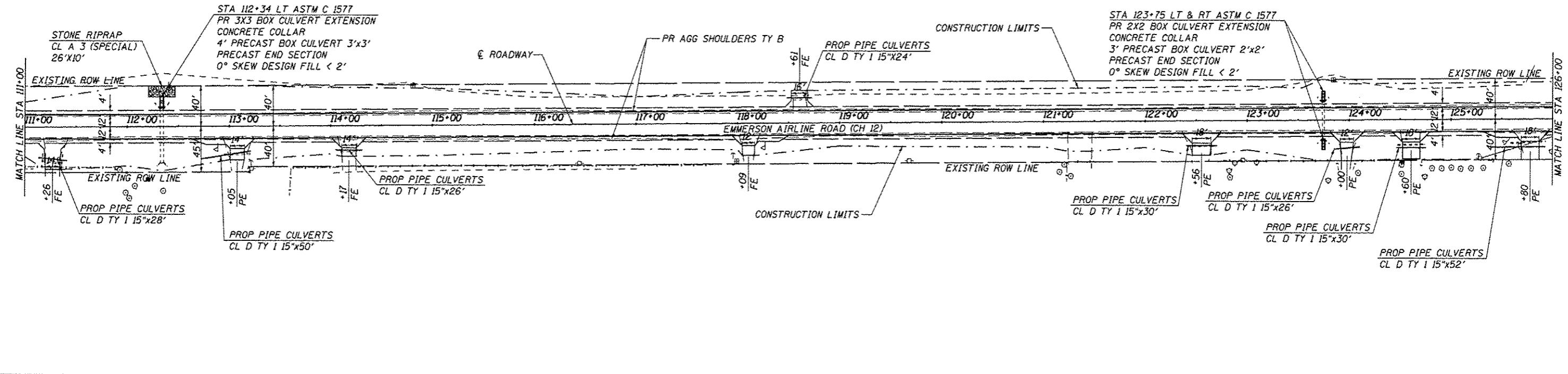

DATE	
BY	
REVISIONS	
NO.	
DESCRIPTION	
DATE	
BY	
REVISIONS	
NO.	
DESCRIPTION	

CEC Cummins Engineering Corporation
Civil and Structural Engineering

JOB # 2184
FILE NAME = 2184p&pdgn
PLOT SCALE = 1/8" = 100'-0" / 1" IN.
PLOT DATE = 12/5/2013

DESIGNED - NAK
DRAWN - TJD
CHECKED - NAK
DATE - 5/31/2011

REVISED -
REVISED -
REVISED -
REVISED -

**MACOUPIN COUNTY
CH 12 IMPROVEMENTS**

PLAN & PROFILE

SCALE: SHEET NO. OF SHEETS STA. 111+00 TO STA. 126+00

F.A.S. RTE.	SECTION	COUNTY	TOTAL SHEETS	SHEET NO.
732	01-00079-00-FP	MACOUPIN	141	32
FED. ROAD DIST. NO. [ILLINOIS] FED. AID PROJECT			CONTRACT NO. 93574	

SEC 35, T12N, R7W, 3RD PM

SEC 36, T12N, R7W, 3RD PM



WALK RD
EAST LINE_SECTION 35

PROP PIPE CULVERTS
CL D TY 1 15"x34"

CONSTRUCTION LIMITS

EXISTING ROW LINE

ROADWAY

EXISTING ROW LINE

EMMERSON AIRLINE ROAD (CH 12)

EXISTING ROW LINE

EXISTING ROW LINE

STA 127+50.00

HOT-MIX ASPHALT SURFACE REMOVAL 1/2"

DATE	
BY	
PLAN	
NO.	
NOTE BOOK	
NO.	
DATE	
BY	
PROFILE	
NO.	
NOTE BOOK	
NO.	
DATE	
BY	

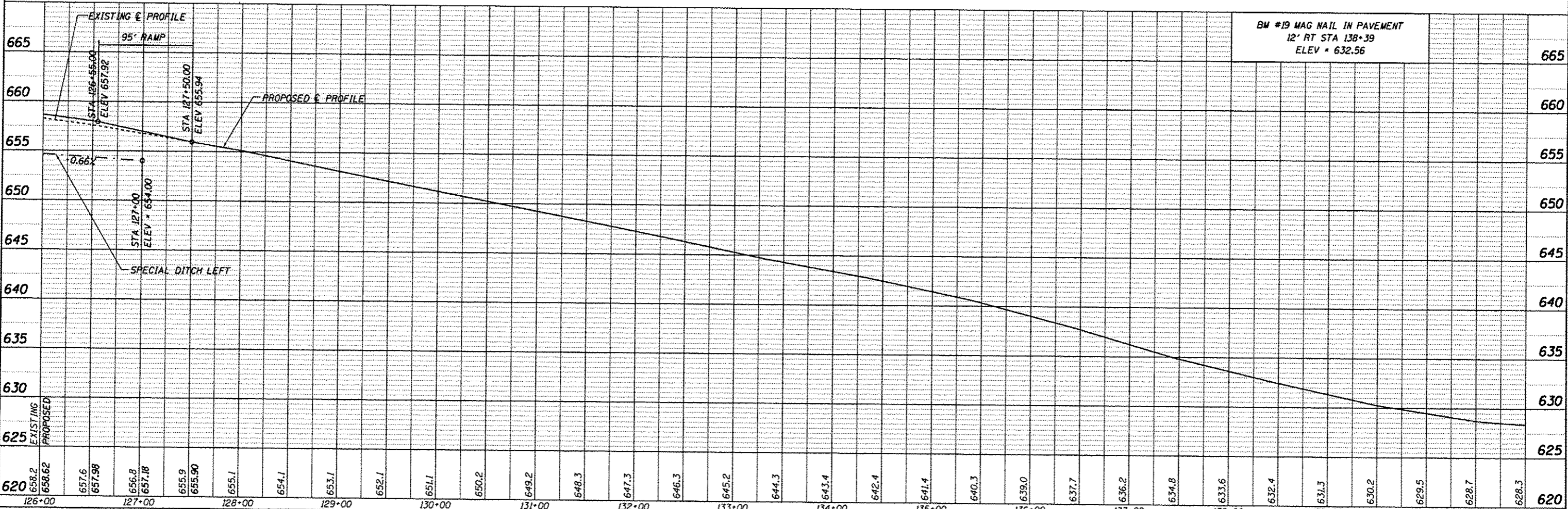

DATE	
BY	
PROFILE	
NO.	
NOTE BOOK	
NO.	
DATE	
BY	

CEC Cummins Engineering Corporation
Civil and Structural Engineering

JOB # 2184
FILE NAME = 2184sp.dgn
PLOT SCALE = 100.000' / IN.
PLOT DATE = 11/21/2013

DESIGNED - NAK
DRAWN - TJD
CHECKED - NAK
DATE - 5/31/2011

REVISED -
REVISED -
REVISED -
REVISED -

**MACOUPIN COUNTY
CH 12 IMPROVEMENTS**

PLAN & PROFILE

SCALE: SHEET NO. OF SHEETS STA. 126+00 TO STA. 141+00

F.A.S. RTE.	SECTION	COUNTY	TOTAL SHEETS	SHEET NO.
732	01-00079-00-FP	MACOUPIN	141	33
FED. ROAD DIST. NO.			ILLINOIS FED. AID PROJECT	
			CONTRACT NO. 93574	

DATE	
BY	
REVIEWED	
PLANNED	
NOTED	
NO. OF WAY CHECKED	
NO. OF BOX CHECKED	
NO. OF FILE NAME	

DATE	
BY	
REVIEWED	
PLANNED	
NOTED	
NO. OF WAY CHECKED	
NO. OF BOX CHECKED	
NO. OF FILE NAME	

SEC 36, T12N, R7W, 3RD PM

STA 150+59 LT ASTM C 1577
PR 2X2 BOX CULVERT EXTENSION
SKEW 13°15' LHF DESIGN FILL < 2'
CONCRETE COLLAR
3' PRECAST BOX CULVERT 2'x2'
PRECAST END SECTION

STA 152+99 LT ASTM C 1577
PR 2X2 BOX CULVERT EXTENSION
SKEW 13°15' LHF DESIGN FILL < 2'
CONCRETE COLLAR
4' PRECAST BOX CULVERT 2'x2'
PRECAST END SECTION

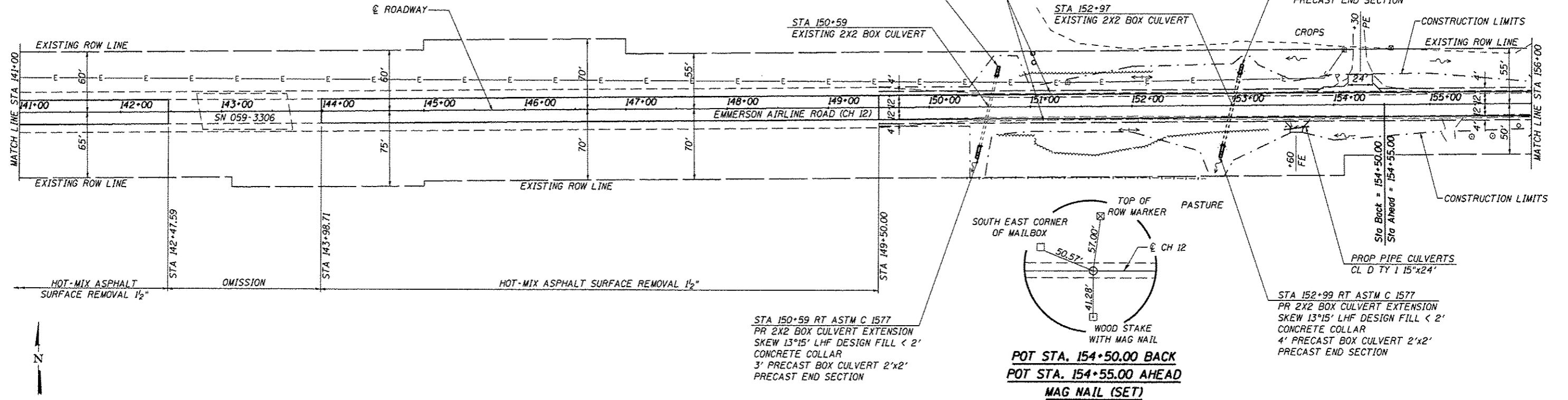

POT STA. 154+50.00 BACK
POT STA. 154+55.00 AHEAD
MAG NAIL (SET)

STA 150+59 RT ASTM C 1577
PR 2X2 BOX CULVERT EXTENSION
SKEW 13°15' LHF DESIGN FILL < 2'
CONCRETE COLLAR
3' PRECAST BOX CULVERT 2'x2'
PRECAST END SECTION

STA 152+99 RT ASTM C 1577
PR 2X2 BOX CULVERT EXTENSION
SKEW 13°15' LHF DESIGN FILL < 2'
CONCRETE COLLAR
4' PRECAST BOX CULVERT 2'x2'
PRECAST END SECTION

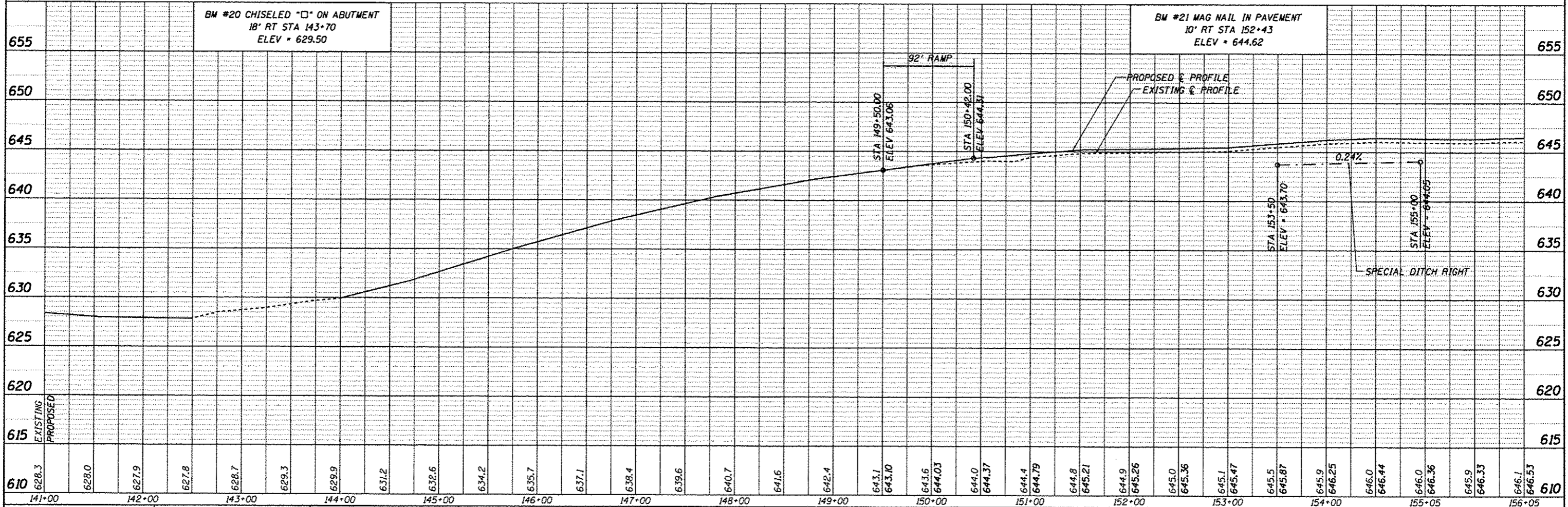

CEC Cummins
Engineering
Corporation
Civil and Structural Engineering

JOB # 2184
FILE NAME = 2184a.p.dgn
PLOT SCALE = 1/8" = 1' IN.
PLOT DATE = 12/5/2013

DESIGNED - NAK
DRAWN - TJD
CHECKED - NAK
DATE - 5/31/2011

REVISED -
REVISED -
REVISED -
REVISED -

**MACOUPIN COUNTY
CH 12 IMPROVEMENTS**

SCALE: SHEET NO. OF SHEETS STA. 141+00 TO STA. 156+00

F.A.S. RTE. 732	SECTION 01-00079-00-FP	COUNTY MACOUPIN	TOTAL SHEETS 141	SHEET NO. 34
CONTRACT NO. 93574			ILLINOIS FED. AID PROJECT	

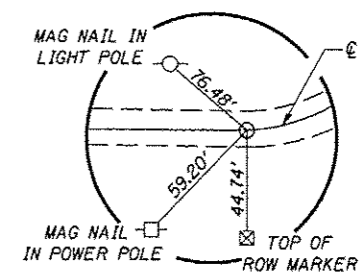
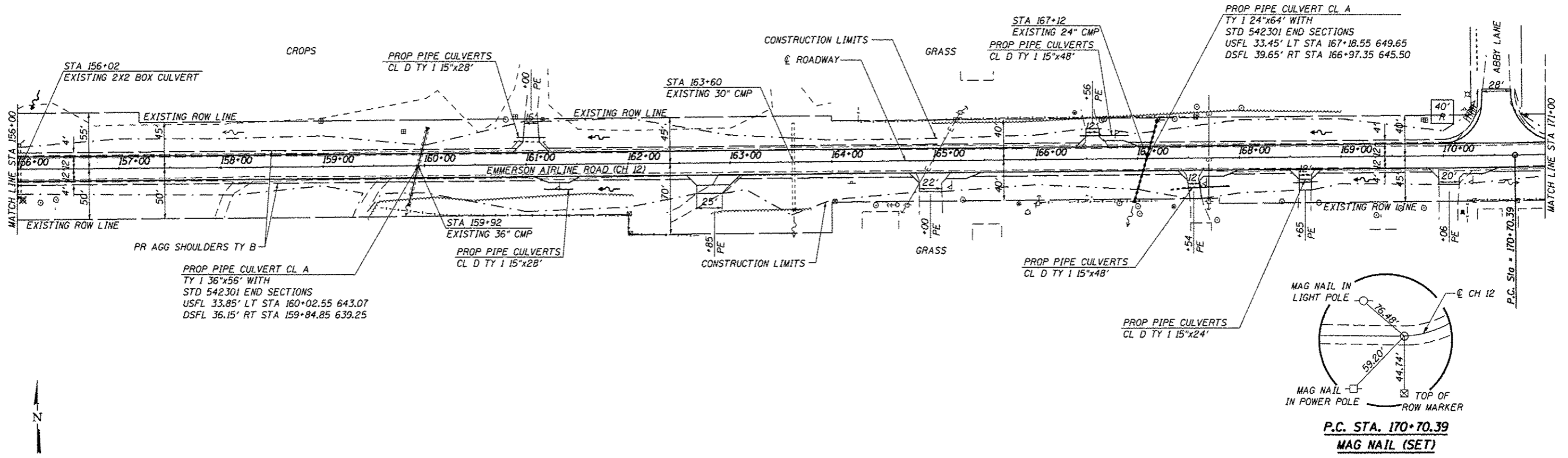

P.C. STA. 170+70.39
MAG NAIL (SET)

DATE	
BY	
REVISIONS	
NOTED	
ALIGNED	
CHECKED	
PLANNED	
FILED	
NO.	

DATE	
BY	
REVISIONS	
NOTED	
ALIGNED	
CHECKED	
PLANNED	
FILED	
NO.	

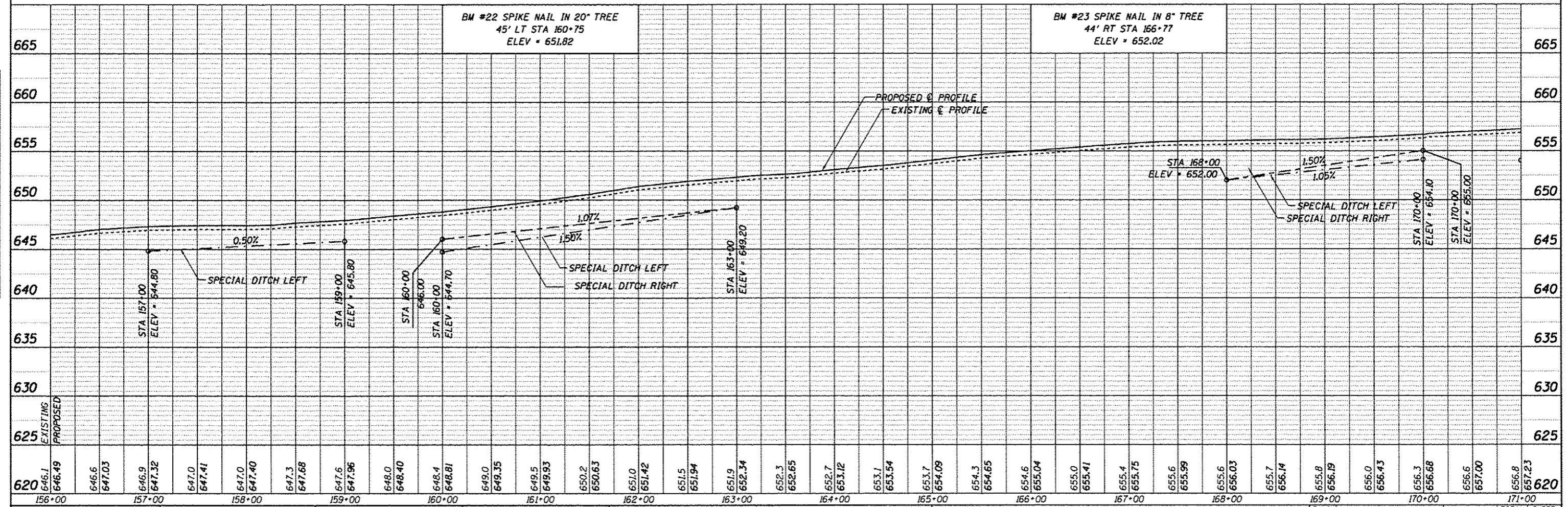

CEC Cummins Engineering Corporation Civil and Structural Engineering	JOB # 2184 FILE NAME = 2184p&p.dgn PLOT SCALE = 1/8" = 100'-0" / IN. PLOT DATE = 12/5/2013	DESIGNED - NAK DRAWN - TJD CHECKED - NAK DATE - 5/31/2011	REVISED - REVISED - REVISED - REVISED -	MACOUPIN COUNTY CH 12 IMPROVEMENTS	PLAN & PROFILE SCALE: SHEET NO. OF SHEETS STA. 156+00 TO STA. 171+00	F.A.S. RTE. 732 SECTION 01-00079-00-PP COUNTY MACOUPIN TOTAL SHEETS 141 SHEET NO. 35 CONTRACT NO. 93574 FED. ROAD DIST. NO. ILLINOIS FED. AID PROJECT
--	---	--	--	---------------------------------------	---	---

CURVE DATA
 PI = STA 176+04.91
 $\Delta = 49^\circ 59' 57''$
 $D = 4^\circ 59' 59''$
 $R = 1146.30$
 $T = 534.52$
 $L = 1000.32$
 $E = 118.50$
 PC = STA 170+70.39
 PT = STA 180+70.71
 $SE = 7.5\%$
 $SE = \text{TRANSITION LENGTH } 198'$
 ATTAIN FROM STA 169+21.89 TO STA 171+19.89
 REMOVE FROM STA 180+21.21 TO STA 182+19.21

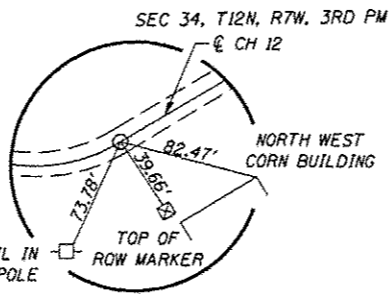

P.T. STA. 180+70.71
MAG NAIL (SET)

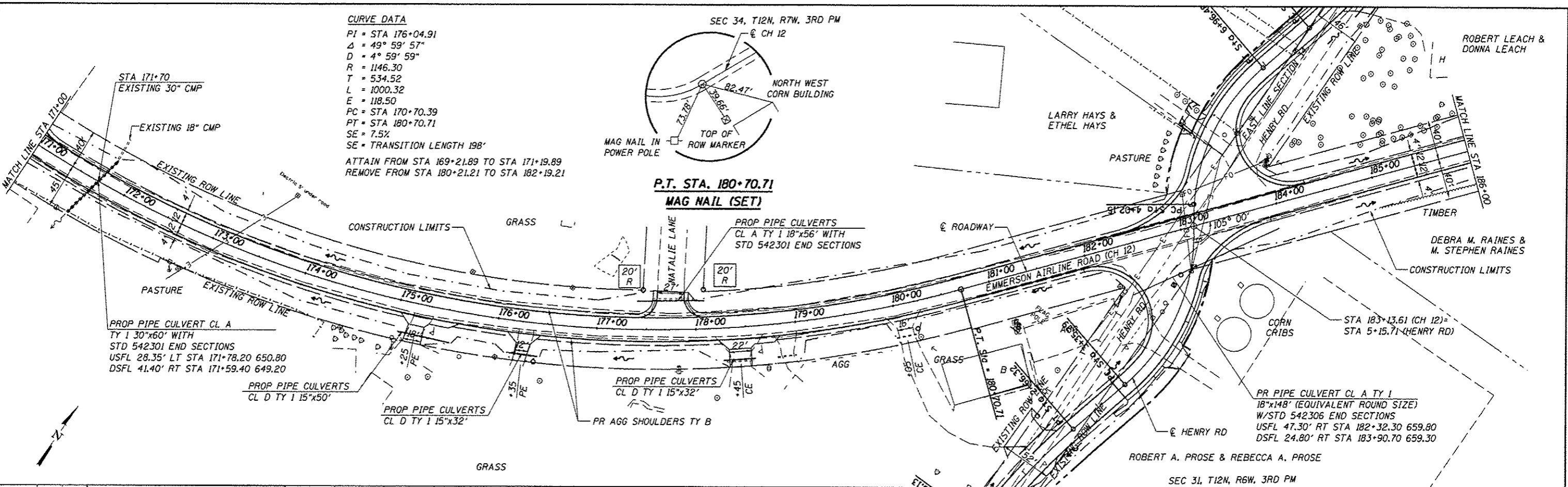

DATE	
BY	
CHECKED	
DESIGNED	
PLANNED	
NOTED	
NO.	

DATE	
BY	
CHECKED	
DESIGNED	
PLANNED	
NOTED	
NO.	

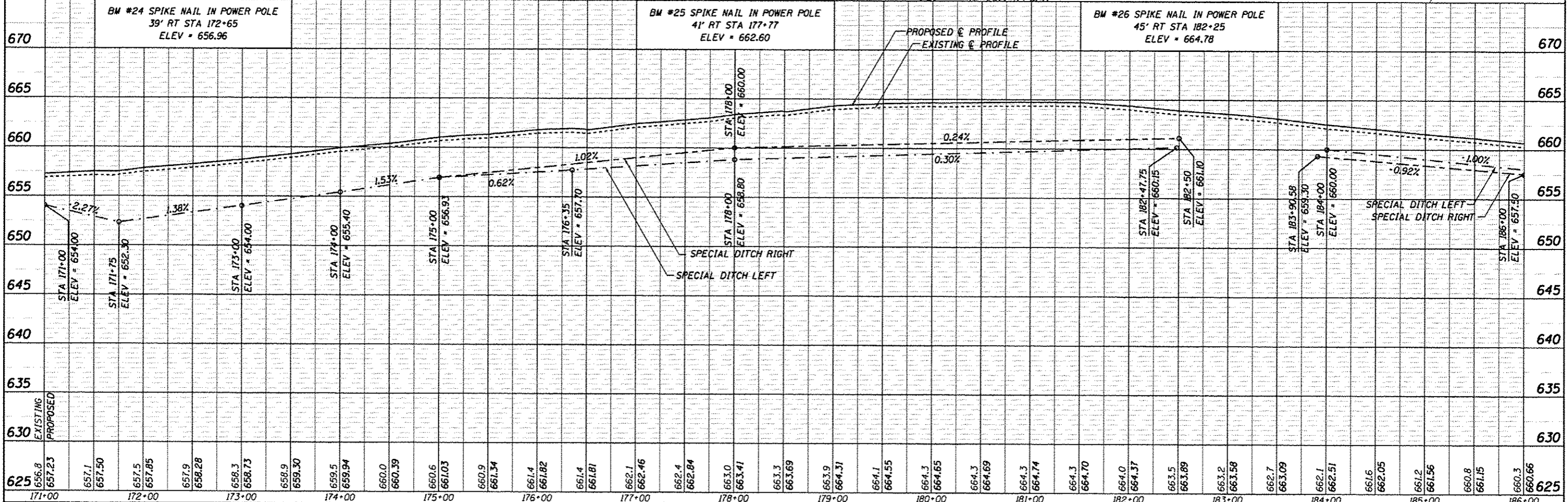

CEC Cummins Engineering Corporation Civil and Structural Engineering	JOB = 2184 FILE NAME = 2184p&p.dgn PLOT SCALE = 100,000 / IN. PLOT DATE = 12/9/2013	DESIGNED - NAK DRAWN - TJD CHECKED - NAK DATE - 5/31/2011	REVISED - REVISED - REVISED - REVISED -	MACOUPIN COUNTY CH 12 IMPROVEMENTS	PLAN & PROFILE	SCALE: SHEET NO. OF SHEETS STA. 171+00 TO STA. 186+00	F.A.S. RTE. SECTION COUNTY TOTAL SHEETS SHEET NO. 732 01-00079-00-FP MACOUPIN 141 36 CONTRACT NO. 93574
--	--	--	--	---	---------------------------	---	---

DATE	
BY	
APPROVED	
DESIGNED	
DRAWN	
CHECKED	
PLT	
SCALE	
DATE	

DATE	
BY	
APPROVED	
DESIGNED	
DRAWN	
CHECKED	
PLT	
SCALE	
DATE	

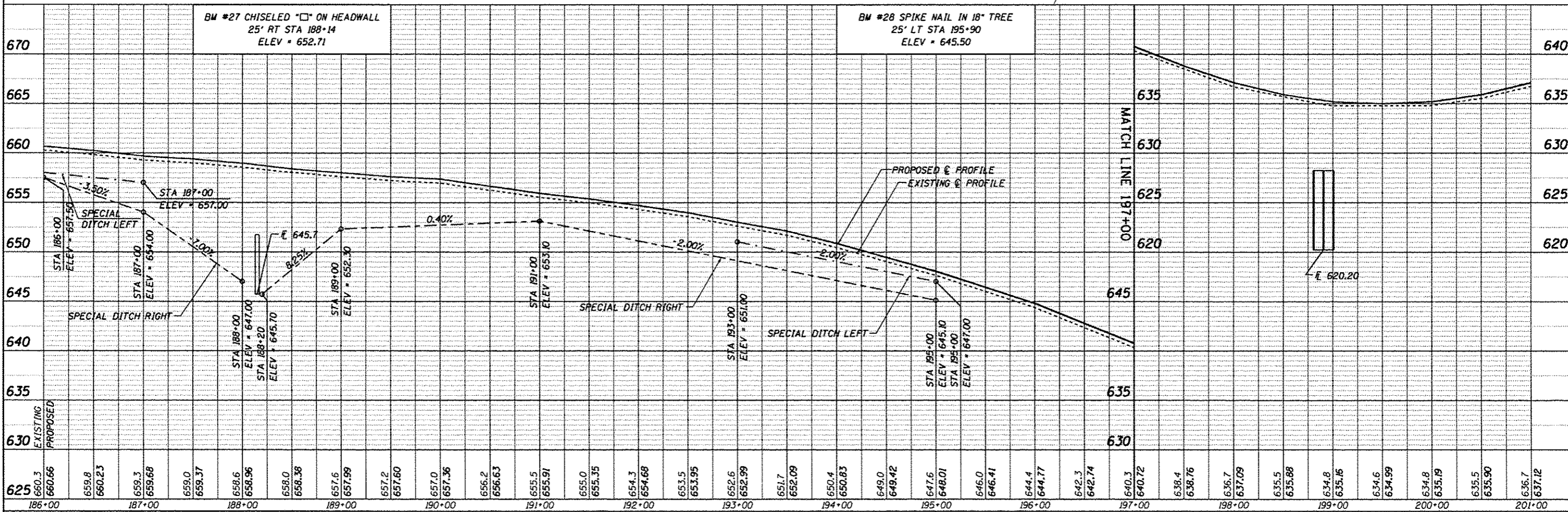
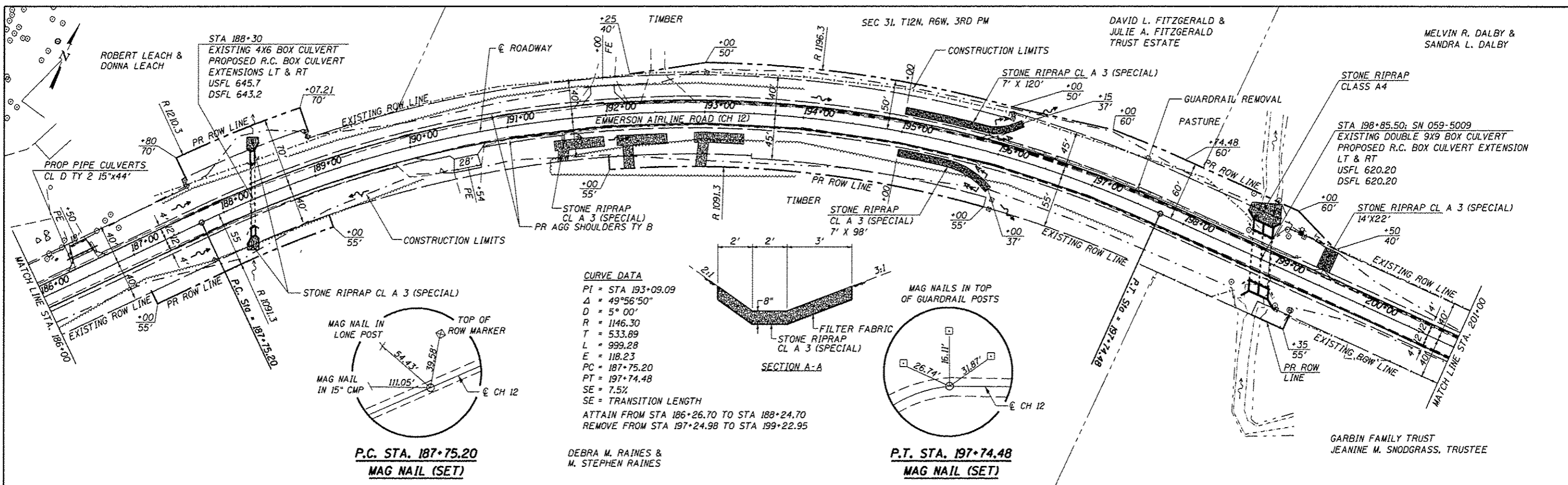

CEC Cummins Engineering Corporation Civil and Structural Engineering	JOB # 2184	DESIGNED - NAK	REVISED -	MACOUPIN COUNTY CH 12 IMPROVEMENTS	PLAN & PROFILE	F.A.S. RTE. 732	SECTION 01-00079-00-FP	COUNTY MACOUPIN	TOTAL SHEETS 141	SHEET NO. 37
	FILE NAME = 2184p&p.dgn	DRAWN - TJD	REVISED -			SCALE: SHEET NO. OF SHEETS STA. 186+00 TO STA. 201+00	FED. ROAD DIST. NO.	ILLINOIS FED. AID PROJECT	CONTRACT NO. 93574	
PLT SCALE = 1/8\"/>										

DATE	
BY	
PLAN	
NO.	
NOTE BOOK	
NO.	
FILE NAME	

DATE	
BY	
PROFILE	
NO.	
NOTE BOOK	
NO.	
FILE NAME	

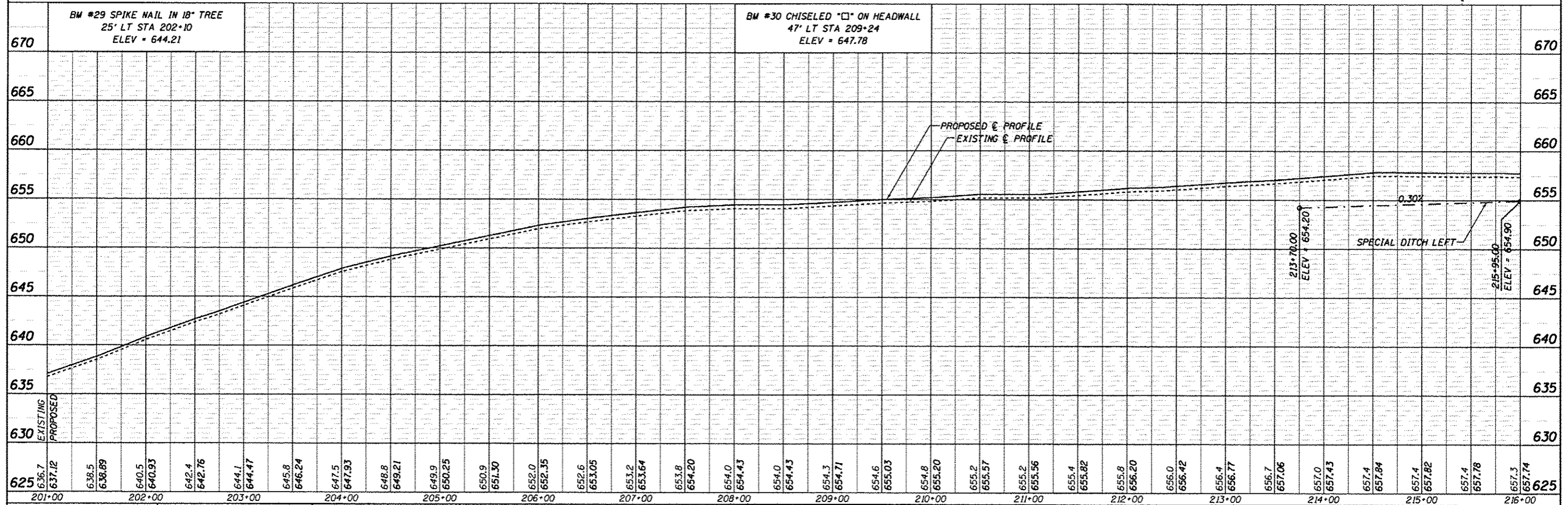
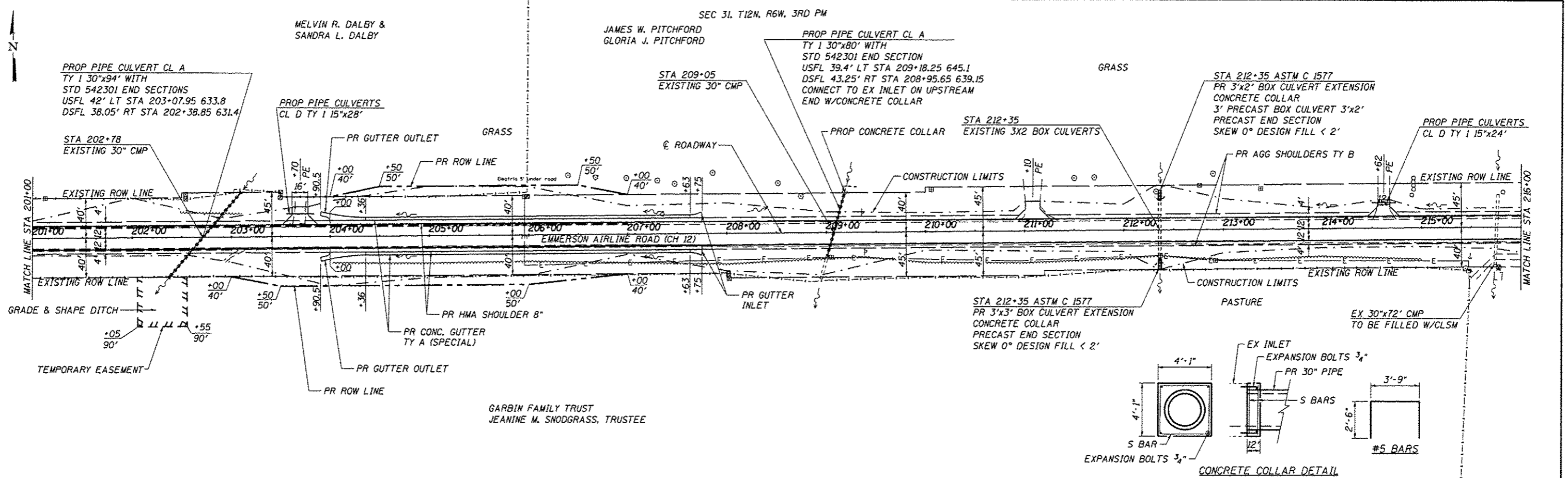

CEC Cummins Engineering Corporation Civil and Structural Engineering	JOB : 2184 FILE NAME : 2184p.dgn PLOT SCALE : 1/8\"/>	DESIGNED - NAK DRAWN - TJD CHECKED - NAK DATE - 5/31/2011	REVISED - REVISED - REVISED - REVISED -	MACOUPIN COUNTY CH 12 IMPROVEMENTS				PLAN & PROFILE				F.A.S. RTE. 732 SECTION 01-00079-00-FP COUNTY MACOUPIN TOTAL SHEETS 141 SHEET NO. 38 CONTRACT NO. 93574
	SCALE: SHEET NO. OF SHEETS STA. 201+00 TO STA. 216+00										FED. ROAD DIST. NO. ILLINOIS FED. AID PROJECT	
	FEDERAL AID PROJECT NO.											
	CONTRACT NO. 93574											

TERRY W. ULERY &
BETTY J. ULERY

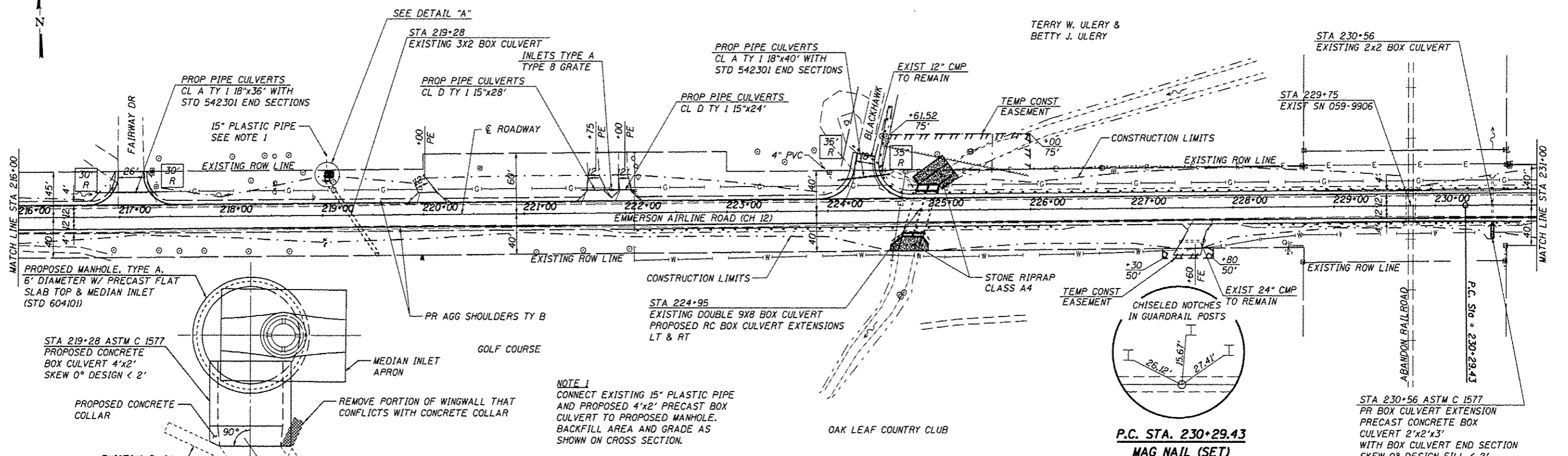

DATE	
BY	
PLANNED	
CHECKED	
NO.	

DATE	
BY	
PROFILING	
CHECKED	
NO.	

NOTE 1
CONNECT EXISTING 15" PLASTIC PIPE AND PROPOSED 4'x2' PRECAST BOX CULVERT TO PROPOSED MANHOLE. BACKFILL AREA AND GRADE AS SHOWN ON CROSS SECTION.

P.C. STA. 230+29.43
MAG NAIL (SET)

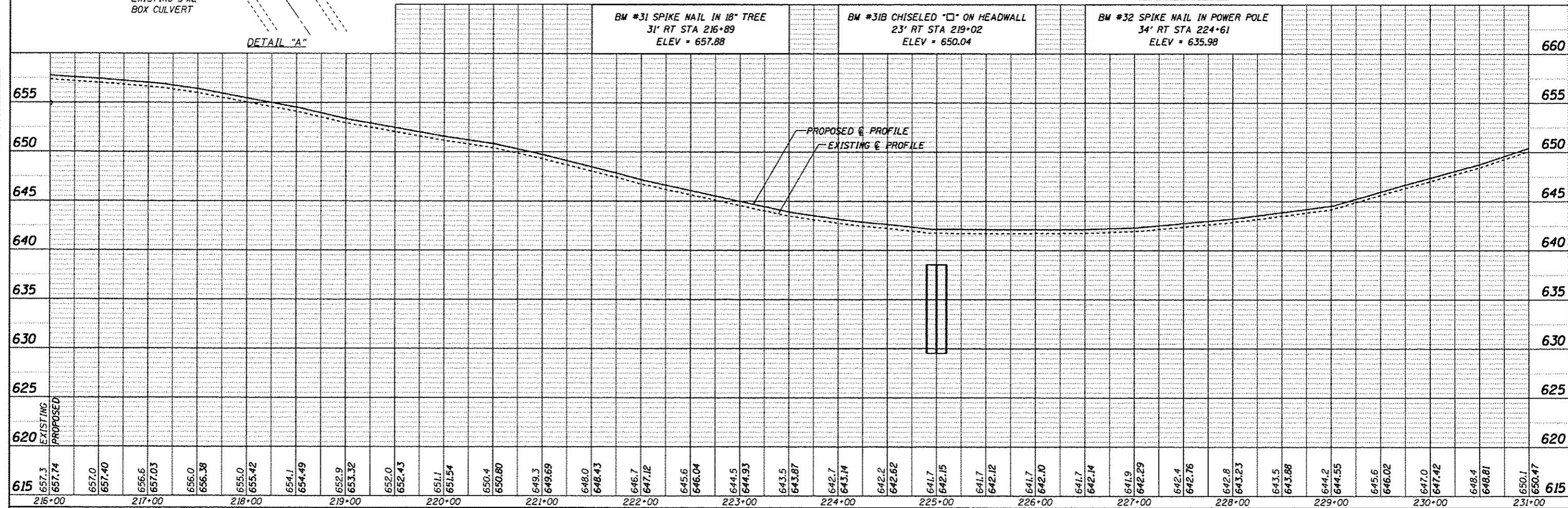

CEC Cummins Engineering Corporation Civil and Structural Engineering	JOB # 2184	DESIGNED - NAK	REVISED -	MACOUPIN COUNTY CH 12 IMPROVEMENTS	PLAN & PROFILE	F.A.S. RTE. 732	SECTION 01-00079-00-FP	COUNTY MACOUPIN	TOTAL SHEETS 141	SHEET NO. 39	
	FILE NAME 2184p&g.dgn	DRAWN - TJD	REVISED -			SCALE:	SHEET NO. OF SHEETS	STA. 216+00 TO STA. 231+00	FED. ROAD DIST. NO.	ILLINOIS FED. AID PROJECT	CONTRACT NO. 93574
	PLDT SCALE = 1/8" = 100.000' / IN.	CHECKED - NAK	REVISED -								
	PLDT DATE = 12/5/2013	DATE - 5/31/2011	REVISED -								

SEC 31, T12N, R6W, 3RD PM

SEC 32, T12N, R6W, 3RD PM

CURVE DATA

PI = STA 237+29.37
 $\Delta = 4^\circ 50' 00''$
 $D = 1^\circ 12'$
 $R = 4774.62$
 $T = 201.51$
 $L = 402.78$
 $E = 4.25$
 $PC = STA 235+27.86$
 $PT = STA 239+30.64$
 $SE = 3.0\%$
 $SE = TRANSITION LENGTH 99'$
 ATTAIN FROM OX AT STA 234+27.86
 TO MATCH EXISTING SLOPE AT STA 235+78

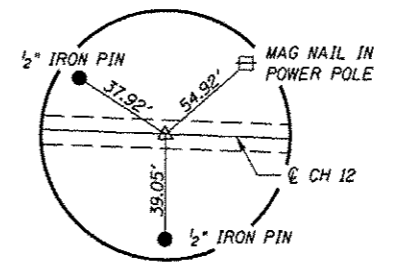

P.I. STA. 232+28.86
MAG NAIL (SET)

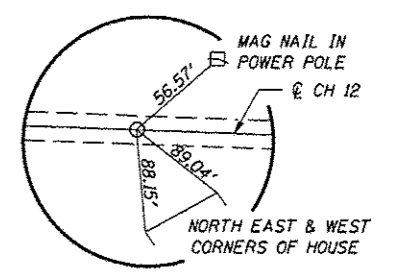

P.T. STA. 234+28.05
MAG NAIL (SET)

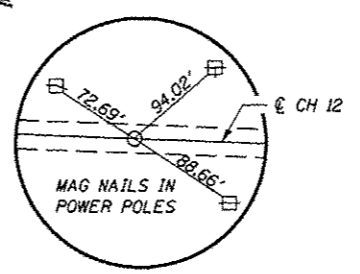

P.C. STA. 235+27.86
MAG NAIL (SET)

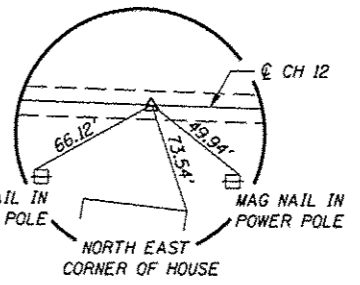

P.I. STA. 237+29.37
MAG NAIL (SET)

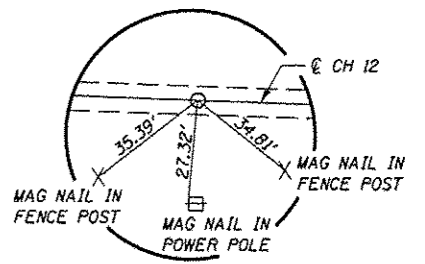

P.T. STA. 239+30.64
MAG NAIL (SET)

CURVE DATA
 PI = STA 232+28.86
 $\Delta = 4^\circ 47' 00''$
 $D = 1^\circ 12' 00''$
 $R = 4774.70$
 $T = 199.42$
 $L = 398.61$
 $E = 4.16$
 $PC = STA 230+29.43$
 $PT = STA 234+28.05$
 $SE = 3.0\%$
 $SE = TRANSITION LENGTH 99'$
 ATTAIN FROM STA 229+55.18 TO STA 230+54.18
 REMOVE FROM STA 234+03.30 TO OX AT STA 234+27.86

PLAN	DATE
CONVERTED	
PLOTTED	
ALIGNED	
FILED	
NO.	

PROFILE	DATE
SURVEYED	
PLOTTED	
GRADES CHECKED	
STRUCTURE NOTATIONS OK'D	
NO.	

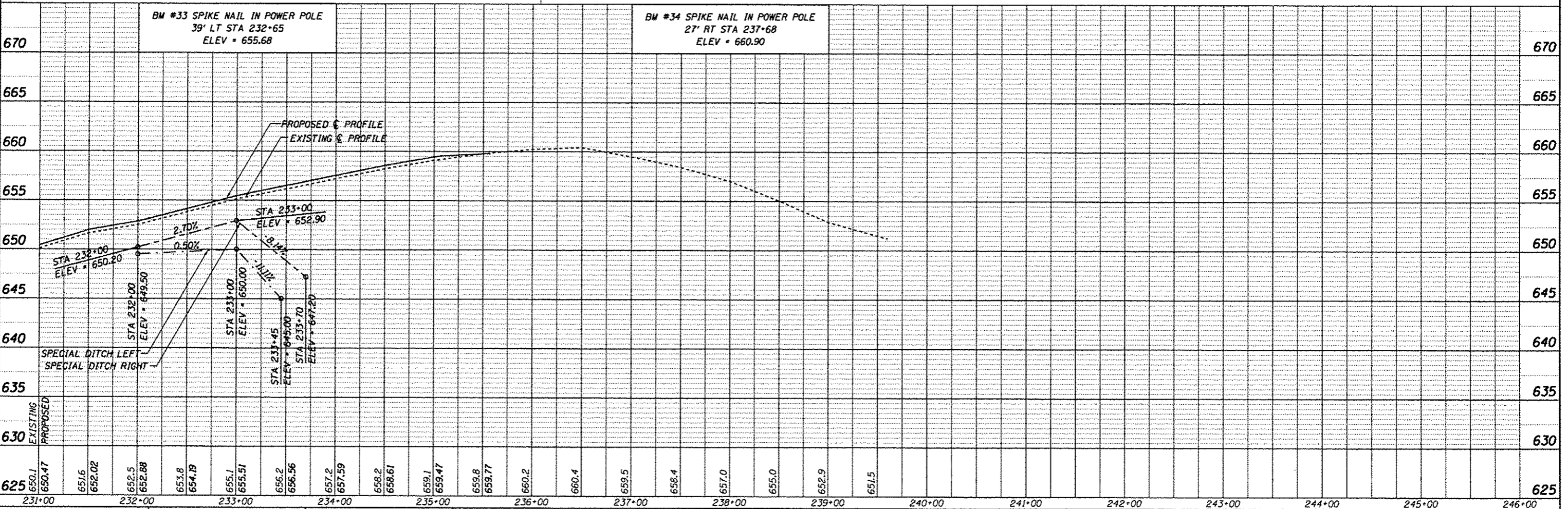

DATE	
BY	
APPROVED	
DESIGNED	
CHECKED	
STRUCTURE NOTATIONS	
NO.	

DATE	
BY	
APPROVED	
DESIGNED	
CHECKED	
STRUCTURE NOTATIONS	
NO.	

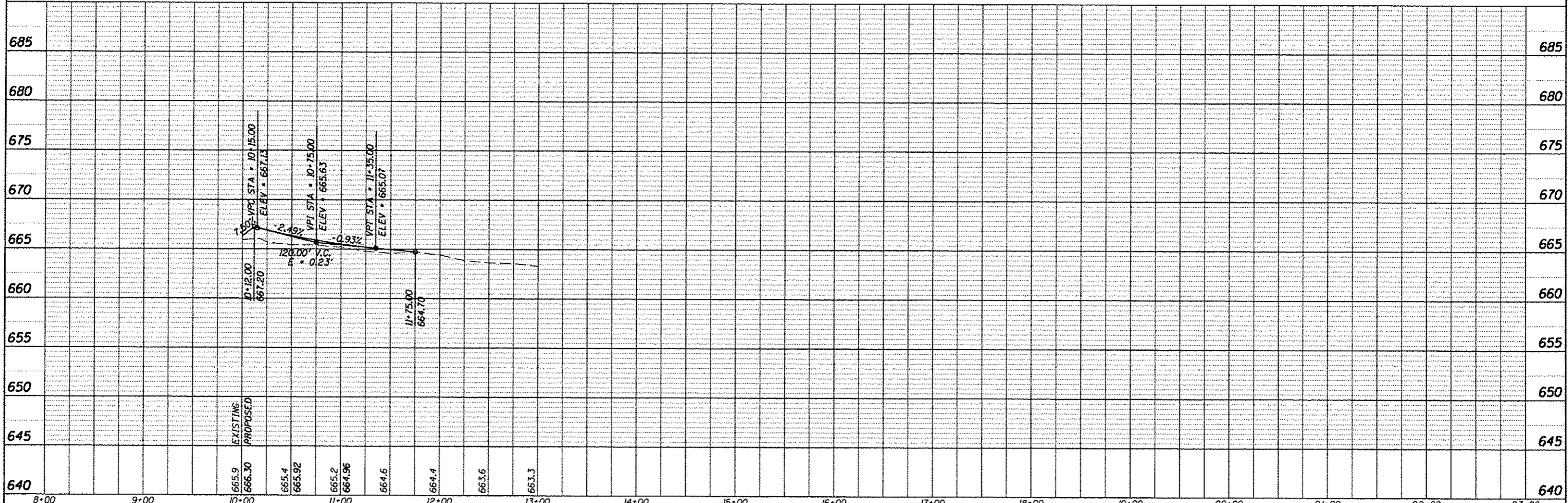
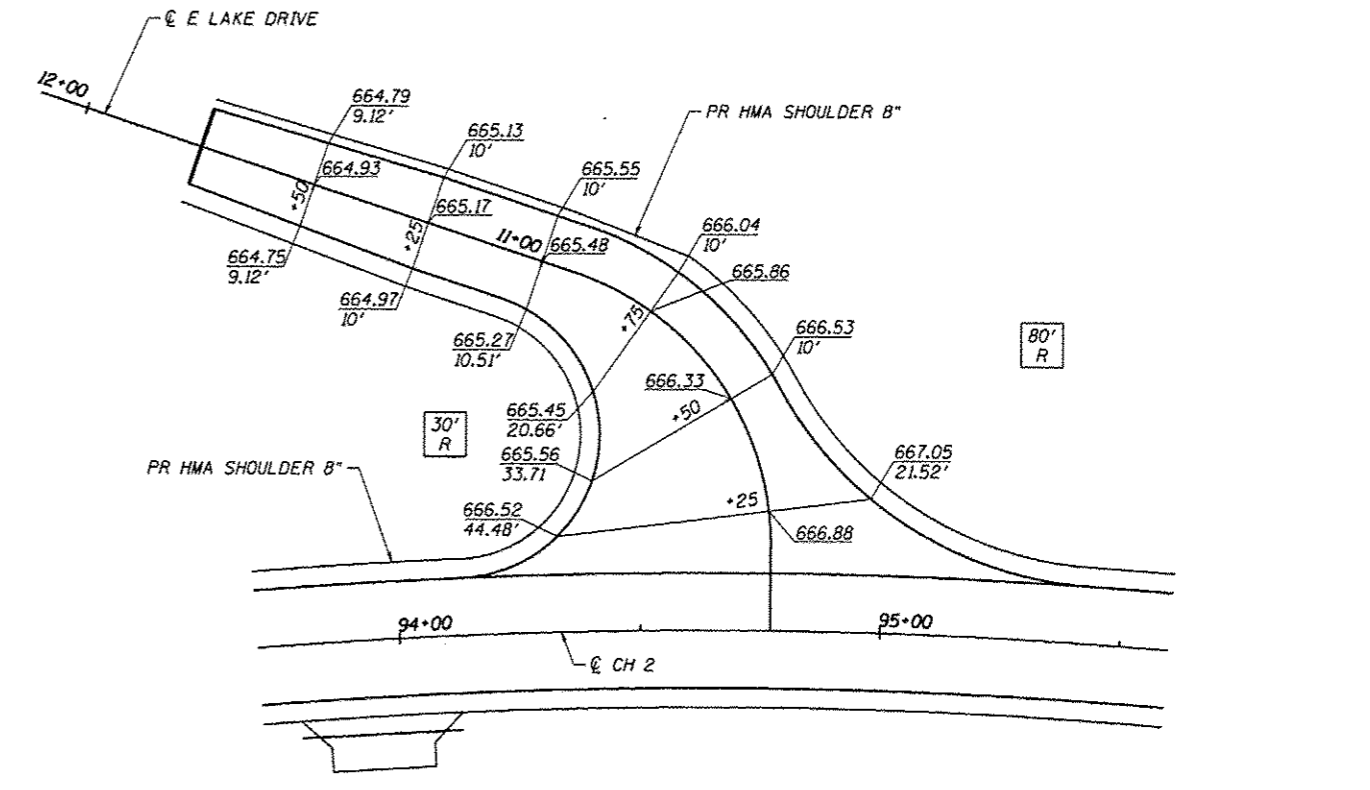
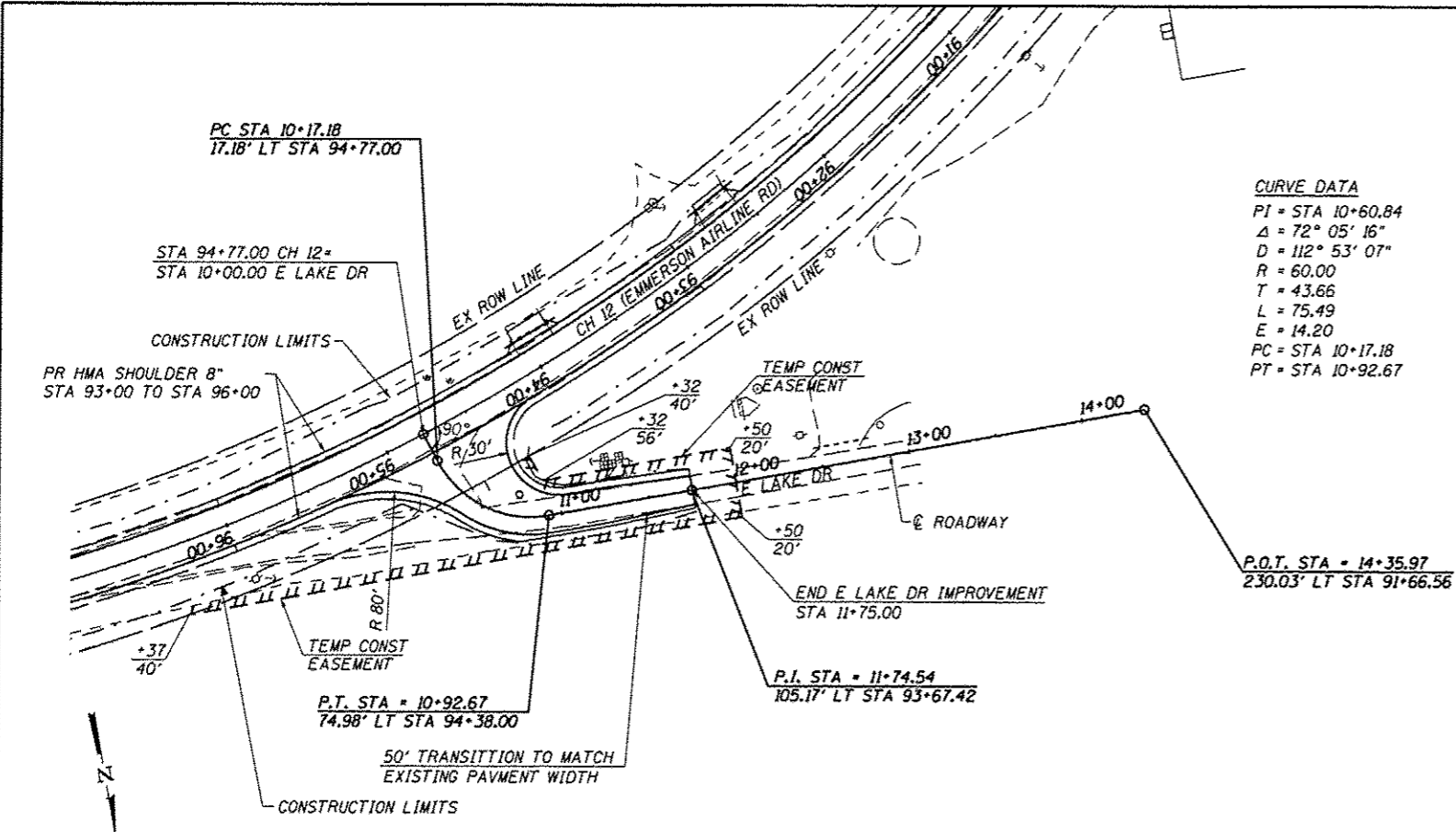

CEC Cummins
Engineering
Corporation

Civil and Structural Engineering

JOB = 2184
FILE NAME = 2184psp.dgn
PLOT SCALE = 1/8" = 1'-0"
PLOT DATE = 11/21/2013

DESIGNED	NAK	REVISED	-
DRAWN	TJD	REVISED	-
CHECKED	NAK	REVISED	-
DATE	7/11/2011	REVISED	-

MACOUPIN COUNTY
CH 12 IMPROVEMENTS

EAST LAKE DR
PLAN & PROFILE

SCALE: SHEET NO. OF SHEETS STA. 10+00.00 TO STA. 14+35.97

F.A.S. RTE.	SECTION	COUNTY	TOTAL SHEETS	SHEET NO.
732	01-00079-00-FP	MACOUPIN	141	41
CONTRACT NO.				93574
FED. ROAD DIST. NO. ILLINOIS FED. AID PROJECT				

SEC 36, T12N, R7W, 3rd PM

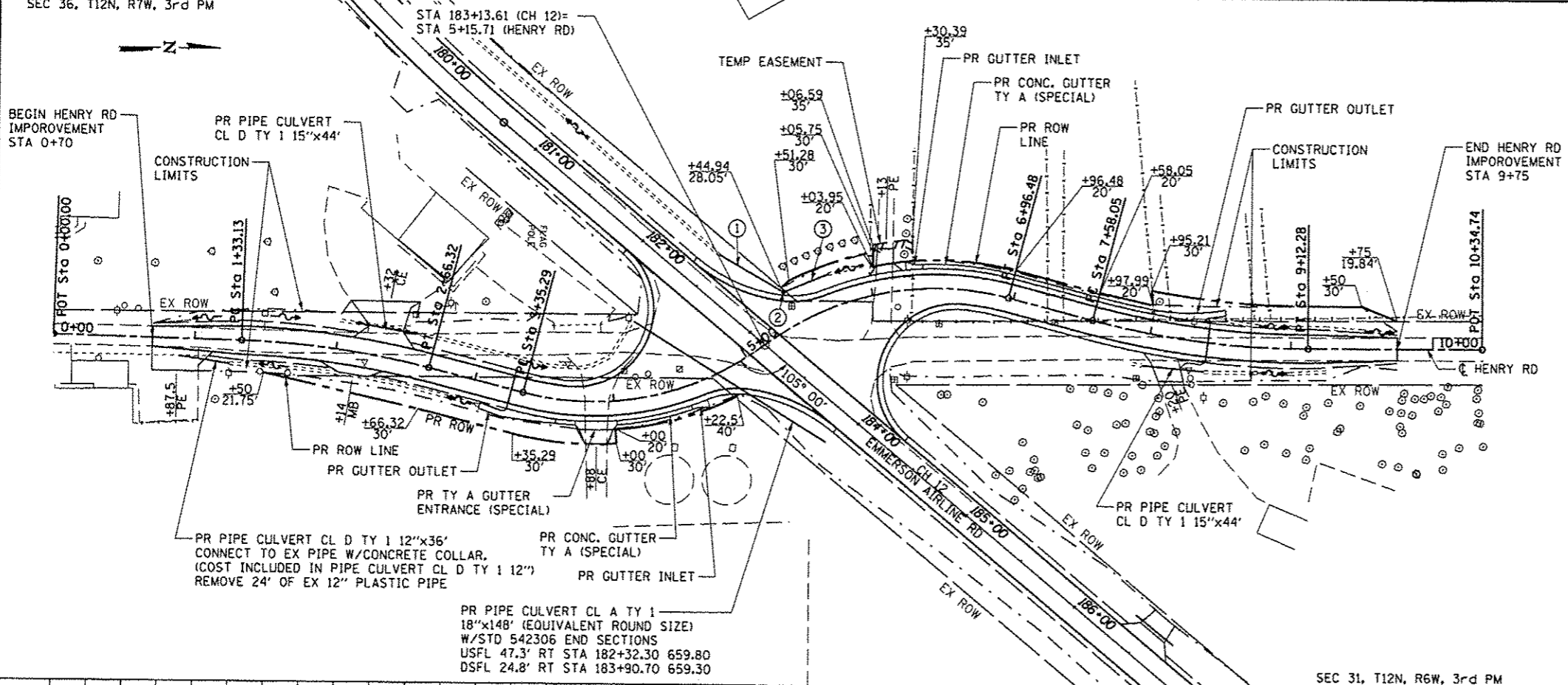

- NOTES
- SEE SHEET 62 FOR DETAILS OF PR CONCRETE GUTTER TY A (SPECIAL) AND PR HMA SHOULDER 8"
 - THE EXISTING OIL & CHIP PAVEMENT AND AGGREGATE SURFACE LT STA 3+65 SHALL BE REMOVED 12" DEEP AND REPLACED WITH EMBANKMENT. EXCAVATION SHALL BE PAID FOR AS EARTH EXCAVATION
 - TRANSITION THE SLOPE OF THE PR HMA SHOULDER 8" FROM -6.0% AT STA 3+75 TO -2.0% AT STA 4+50
 - TRANSITION PROPOSED PAVEMENT TO MATCH EXISTING WIDTH IN 60'
- PR PIPE CULVERT CL D TY 1 15"x52' USFL 36.70' LT STA 182+98.95 660.30 DSFL 27.65' LT STA 182+47.75 660.15
 - PR INLETS TY B, TY 8 GRATE 24.55' LT STA 5+45 # GRATE 662.70 INVERT 660.30
 - PR PIPE CULVERT CL D TY 1 15"x34' USFL 23.35' LT STA 5+75.85 660.42 DSFL 24.5' LT STA 5+45.45 660.30

DATE	
BY	
REVISION	
NO.	
DATE	
BY	
REVISION	
NO.	
DATE	
BY	
REVISION	
NO.	

DATE	
BY	
REVISION	
NO.	
DATE	
BY	
REVISION	
NO.	
DATE	
BY	
REVISION	
NO.	

SEC 31, T12N, R6W, 3rd PM

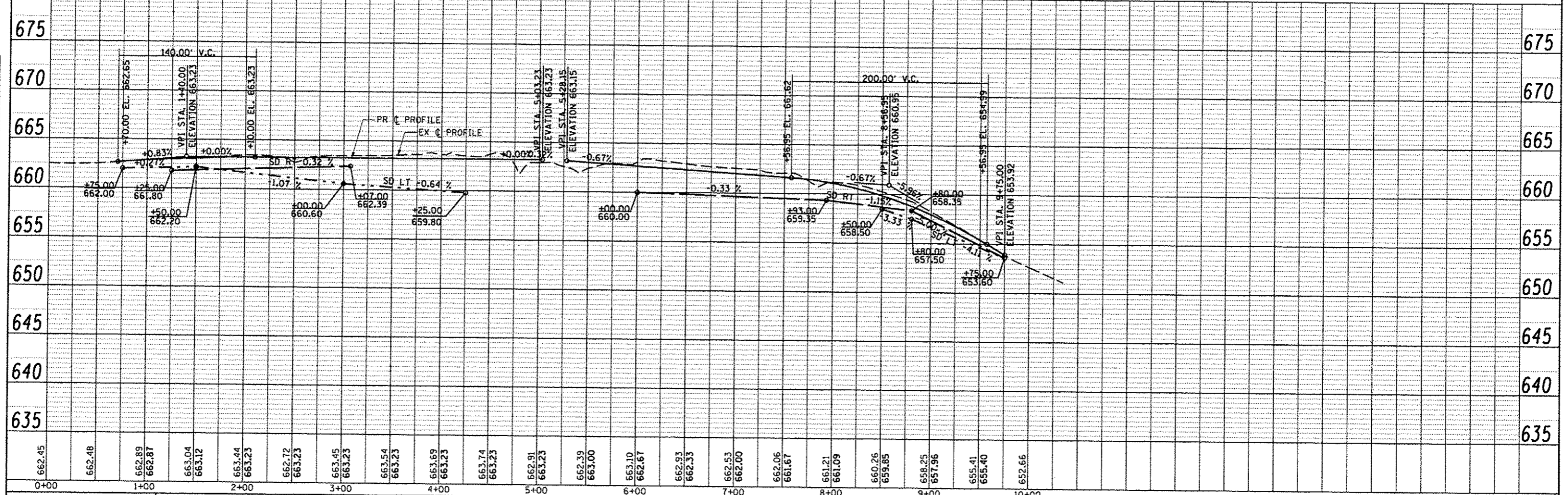

	JOB = 2246 FILE NAME = 2246-plan-henry2.dgn PLOT SCALE = 1/80.0000' / IN. PLOT DATE = 11/21/2013	DESIGNED - DRAWN - CHECKED - DATE -	REVISED - REVISED - REVISED - REVISED -	MACOUPIN COUNTY CH 12 IMPROVEMENTS		HENRY ROAD PLAN & PROFILE		F.A.S. RTE. 732 SECTION 01-00079-00-FP COUNTY MACOUPIN TOTAL SHEETS 141 SHEET NO. 42 CONTRACT NO. 93574
	SCALE: SHEET NO. OF SHEETS STA. TO STA.				FEDERAL ROAD DIST. NO. (ILLINOIS) FED. AID PROJECT			

HENRY RD ALIGNMENT			
CONTROL POINT	STATION	COORDINATES	
		NORTHING	EASTING
P.O.T	0.00	101128.2462	2396581.0752
P.C.	1+33.13	1011281.3451	2396584.3480
P.I.	2+00.00	1011328.2058	2396585.6908
P.T.	2+66.32	1011383.1302	2396601.7217
P.C.	3+35.29	1011460.0807	2396618.2530
P.I.	4+27.24	1011549.3556	2396640.2967
P.T.	5+07.67	1011624.2053	2396588.8790
P.C.	5+23.24	1011636.8790	2396577.8342
P.I.	6+15.71	1011712.1600	2396524.1159
P.T.	6+96.48	1011801.8319	2396548.6666
P.C.	7+58.05	1011881.5497	2396581.8827
P.I.	8+35.59	1011938.7480	2396580.5915
P.T.	9+12.28	1012014.2828	2396579.7822
P.O.T	10+34.74	1012138.7368	2396578.4526

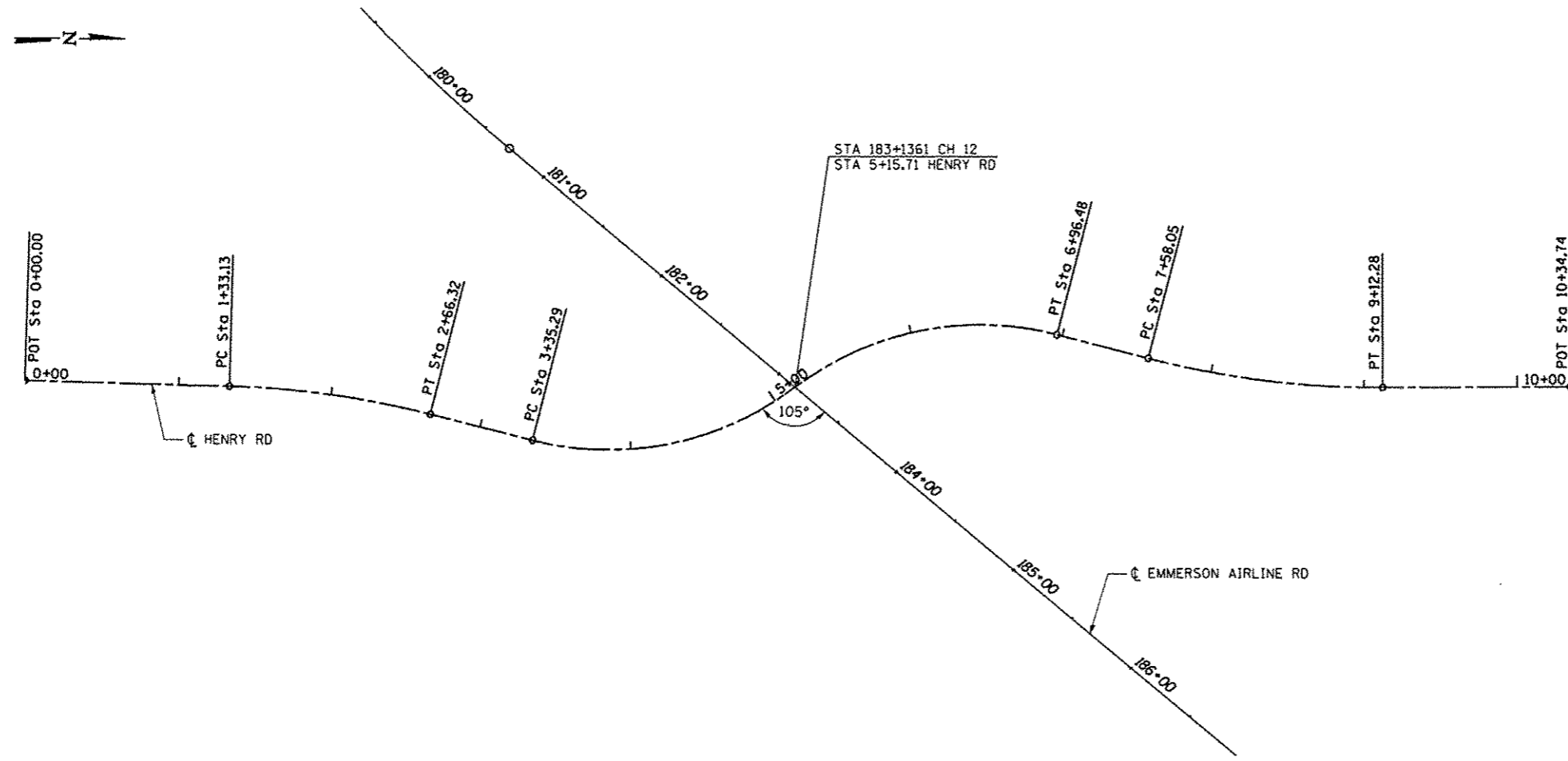

PROP. CURVE S005
 PI STA. = 2+00.00
 $\Delta = 12^\circ 43' 10''$ (RT)
 $D = 9^\circ 32' 57''$
 $R = 600.00'$
 $T = 66.87'$
 $L = 133.20'$
 $E = 3.72'$
 $e = 3.5\%$
 $T.R. = 30$
 $S.E. RUN = 53$
 P.C. STA. = 1+33.13
 P.T. STA. = 2+66.32
 ATTAIN SE STA 0+70.88 TO STA 1+53.88
 REMOVE SE STA 2+57.18 TO STA 3+10.18 (3.5% TO 0%)

PROP. CURVE S006
 PI STA. = 4+27.24
 $\Delta = 49^\circ 23' 03''$ (LT)
 $D = 28^\circ 38' 52''$
 $R = 200.00'$
 $T = 91.96'$
 $L = 172.38'$
 $E = 20.13'$
 $e = 2.0\%$
 $T.R. = 27$
 $S.E. RUN = 27$
 P.C. STA. = 3+35.29
 P.T. STA. = 5+07.67
 ATTAIN SE STA 3+10.18 TO STA 3+37.18 (0.0% TO 2.0%)
 REMOVE SE STA 4+62.28 TO STA 5+03.28 (+2.0% TO -1.0%)

PROP. CURVE S007
 PI STA. = 6+15.71
 $\Delta = 49^\circ 37' 43''$ (RT)
 $D = 28^\circ 38' 52''$
 $R = 200.00'$
 $T = 92.47'$
 $L = 173.24'$
 $E = 20.34'$
 $e = 2.0\%$
 $T.R. = 27$
 $S.E. RUN = 27$
 P.C. STA. = 5+23.24
 P.T. STA. = 6+96.48
 ATTAIN SE STA 5+28.15 TO STA 5+41.65 (1.0% TO 2.0%)
 REMOVE SE STA 6+90.89 TO STA 7+17.89 (2.0% TO 0.0%)

PROP. CURVE S008
 PI STA. = 8+35.59
 $\Delta = 14^\circ 43' 38''$ (LT)
 $D = 9^\circ 32' 57''$
 $R = 600.00'$
 $T = 77.54'$
 $L = 154.22'$
 $E = 4.99'$
 $e = 3.5\%$
 $T.R. = 30$
 $S.E. RUN = 53$
 P.C. STA. = 7+58.05
 P.T. STA. = 9+12.28
 ATTAIN SE STA 7+17.89 TO STA 7+70.89 (0.0% TO 3.5%)
 REMOVE SE STA 8+91.53 TO STA 9+74.53



JOB # 2246	DESIGNED - NAK	REVISED -
FILE NAME = 2246-plan-henry2.dgn	DRAWN - SJS	REVISED -
PLOT SCALE = 1/8" = 1' / IN.	CHECKED - NAK	REVISED -
PLOT DATE = 11/21/2013	DATE - 9/30/2013	REVISED -

**MACOUPIN COUNTY
CH 12 IMPROVEMENTS**

HENRY RD ALIGNMENT

SCALE: SHEET NO. OF SHEETS STA. TO STA.

F.A.S. RTE.	SECTION	COUNTY	TOTAL SHEETS	SHEET NO.
732	01-00079-00-FP	MACOUPIN	141	43
FED. ROAD DIST. NO.			ILLINOIS FED. AID PROJECT	
			CONTRACT NO. 93574	

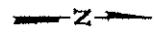

2 CENTER CURVE
 RADIUS 1= 120'
 RADIUS 2= 60'
 OFFSET= 10'

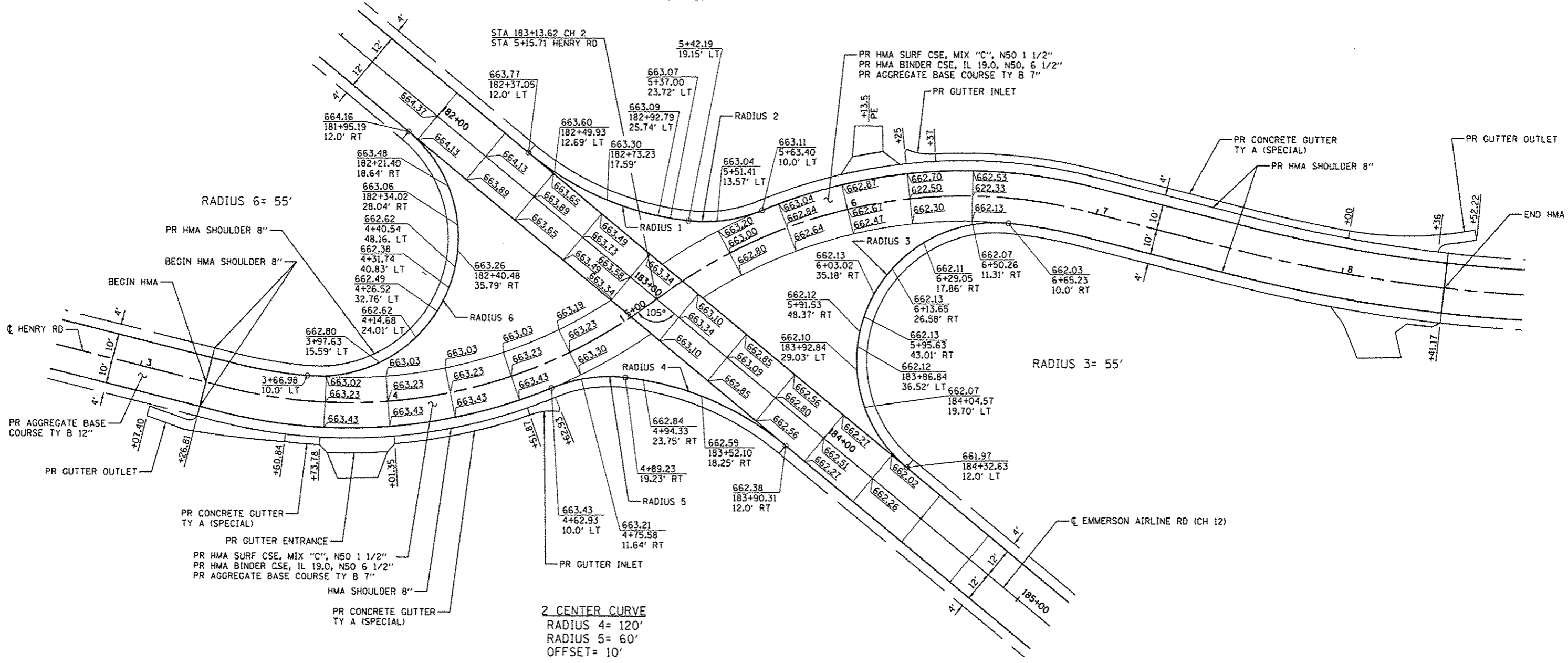

TRANSITION RIGHT SHOULDER FROM 6.0% AT STA 3+75 TO 2.0% AT STA 4+50

2 CENTER CURVE
 RADIUS 4= 120'
 RADIUS 5= 60'
 OFFSET= 10'



JOB # 2246
 FILE NAME = 2246-int-henry2.dgn
 PLOT SCALE = 48.0000' / IN.
 PLOT DATE = 11/21/2013

DESIGNED - NAK
 DRAWN - SJS
 CHECKED - NAK
 DATE - 9/30/2013

REVISED -
 REVISED -
 REVISED -
 REVISED -

MACOUPIN COUNTY
 CH 12 IMPROVEMENTS

HENRY RD INTERSECTION

SCALE: SHEET NO. OF SHEETS STA. TO STA.

F.A.S. RTE.	SECTION	COUNTY	TOTAL SHEETS	SHEET NO.
732	01-00079-00-FP	MACOUPIN	141	44
FED. ROAD DIST. NO. [ILLINOIS] FED. AID PROJECT			CONTRACT NO. 93574	

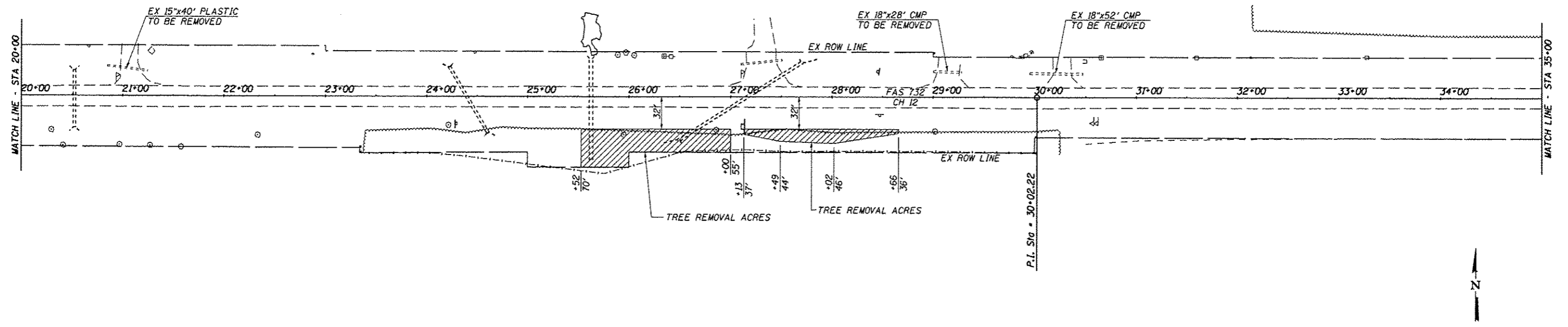
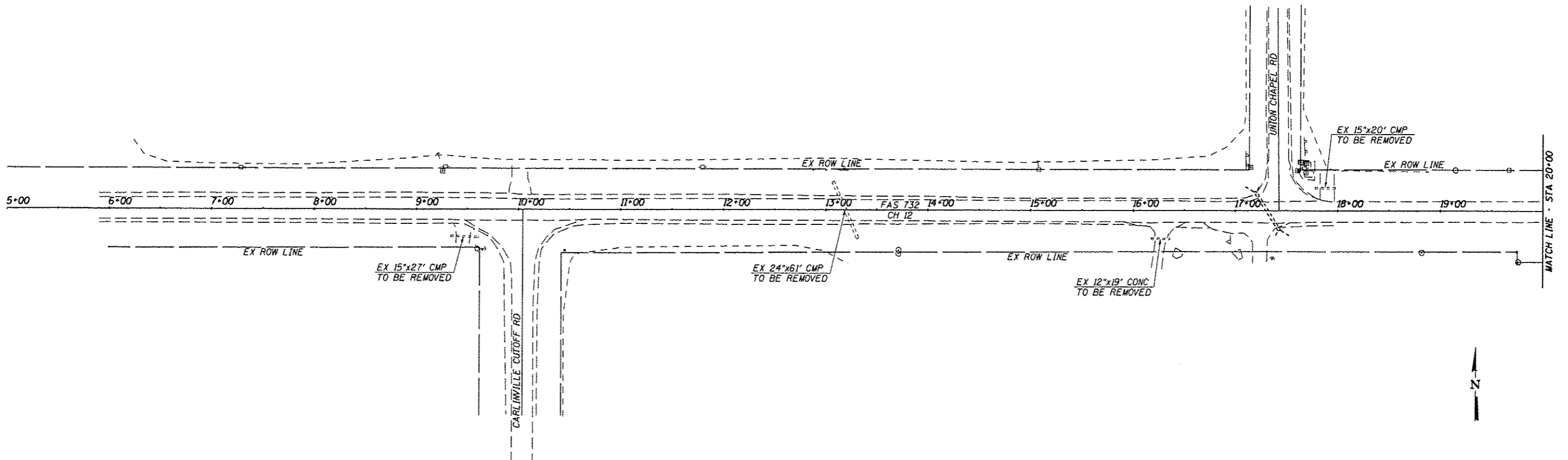

CEC Cummins Engineering Corporation
Civil and Structural Engineering

JOB # 2184
FILE NAME = 2184*.em.dgn
PLOT SCALE = 1/8" = 1' / IN.
PLOT DATE = 12/5/2013

DESIGNED - NAK
DRAWN - TJD
CHECKED - NAK
DATE - 7/11/2011

REVISED -
REVISED -
REVISED -

**MACOUPIN COUNTY
CH 12 IMPROVEMENTS**

REMOVAL PLAN
SCALE: SHEET NO. OF SHEETS STA. TO STA.

F.A.S. RTE.	SECTION	COUNTY	TOTAL SHEETS	SHEET NO.
732	01-00079-00-FP	MACOUPIN	141	45
FED. ROAD DIST. NO. ILLINOIS FED. AID PROJECT			CONTRACT NO. 93574	

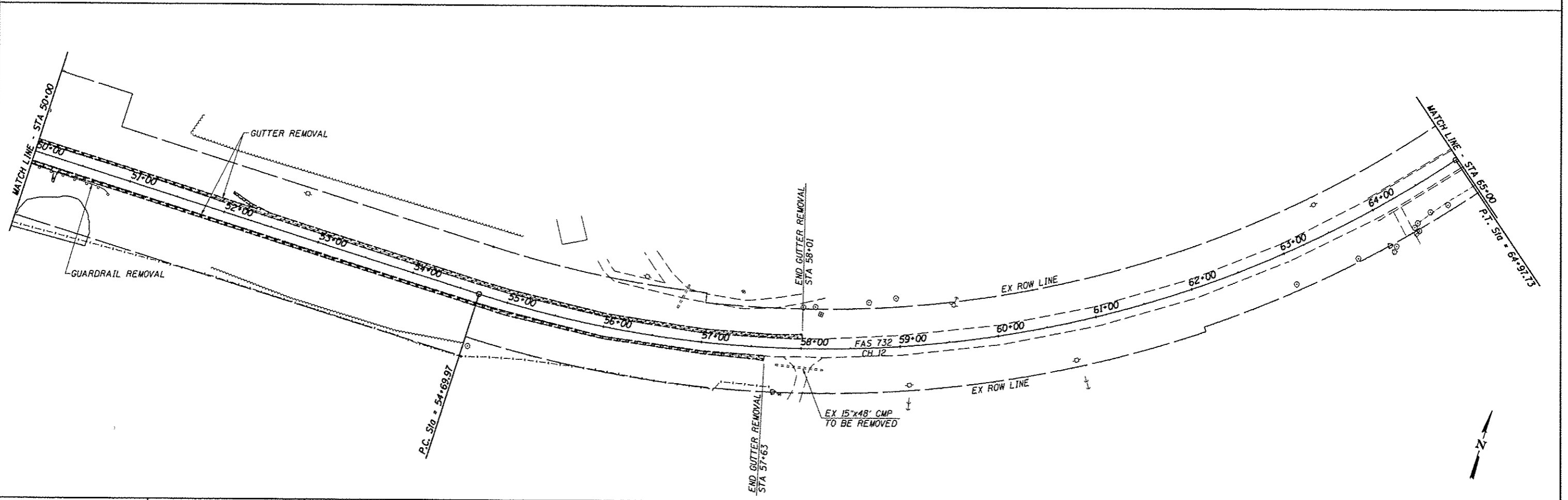
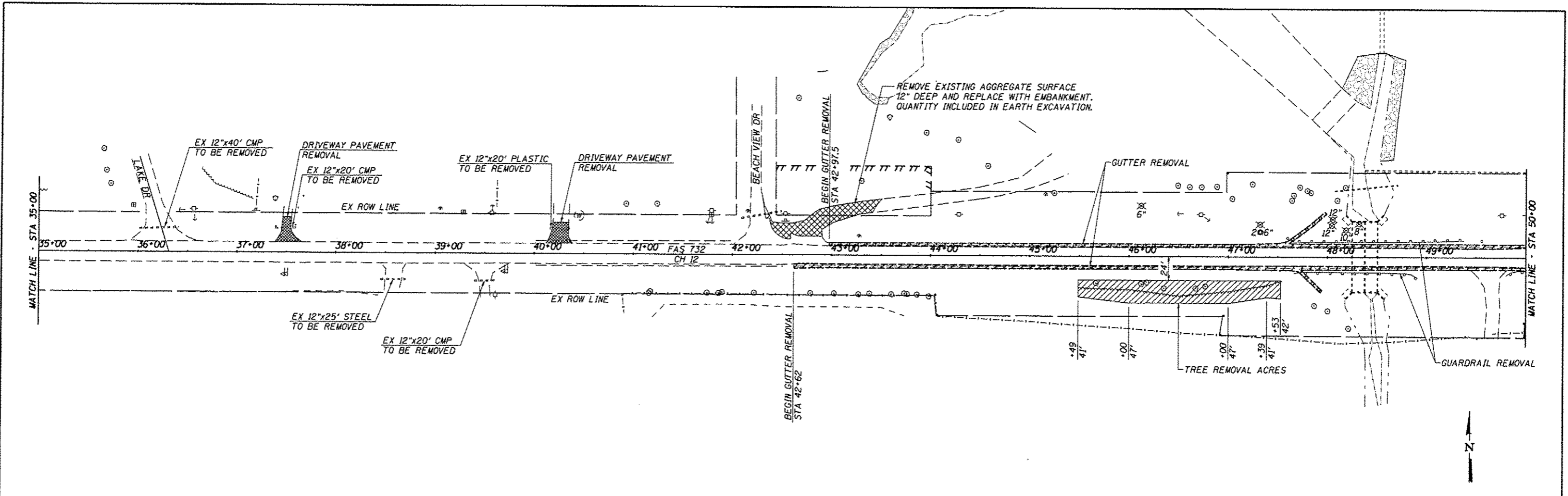

CEC Cummins
Engineering
Corporation
Civil and Structural Engineering

JOB # 2184
FILE NAME # 2184ram.dgn
PLOT SCALE = 100.00' / IN.
PLOT DATE = 11/21/2013

DESIGNED - NAK
DRAWN - TJD
CHECKED - NAK
DATE - 7/11/2011

REVISED -
REVISED -
REVISED -
REVISED -

**MACOUPIN COUNTY
CH 12 IMPROVEMENTS**

REMOVAL PLAN
SCALE: SHEET NO. OF SHEETS STA. TO STA.

F.A.S. RTE.	SECTION	COUNTY	TOTAL SHEETS	SHEET NO.
732	01-00079-00-FP	MACOUPIN	141	46
FED. ROAD DIST. NO.		ILLINOIS FED. AID PROJECT		
		CONTRACT NO. 93574		

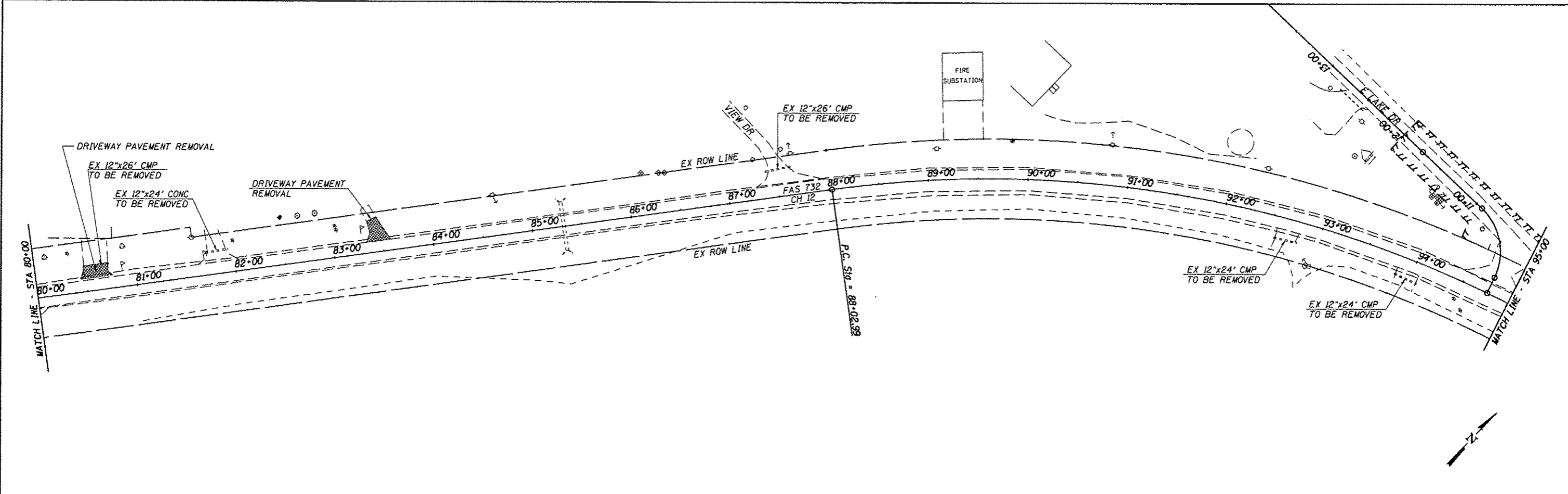
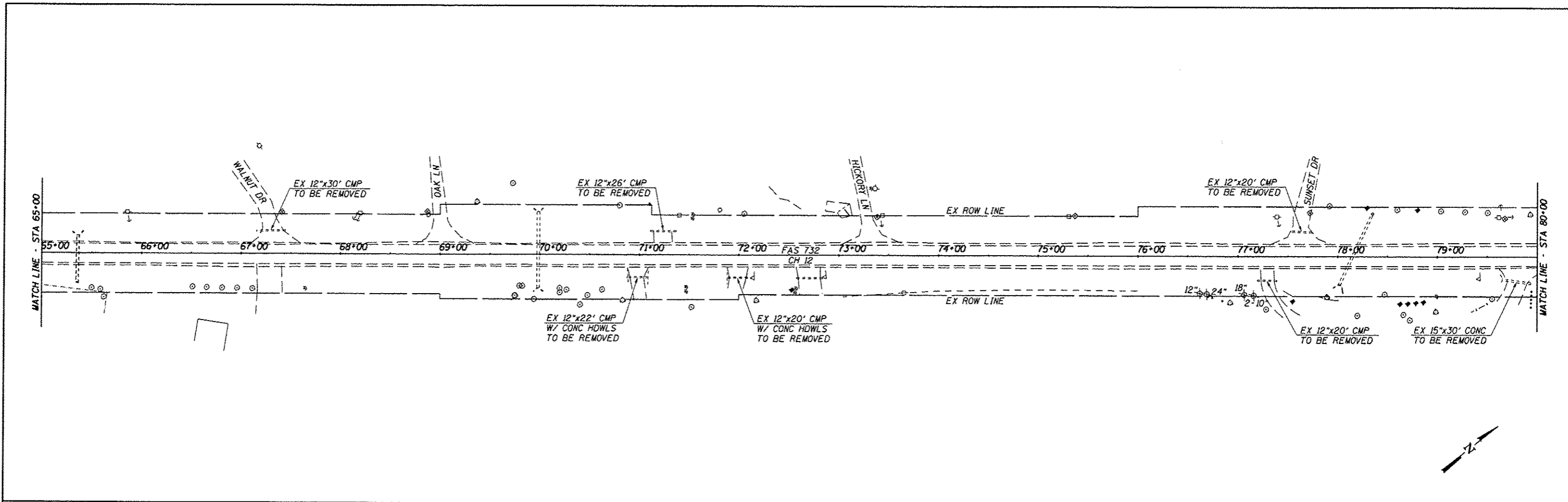

CEC Cummins Engineering Corporation Civil and Structural Engineering	JOB # 2184	DESIGNED - NAK	REVISED -	MACOUPIN COUNTY CH 12 IMPROVEMENTS	REMOVAL PLAN			F.A.S. RTE. 732	SECTION 01-00079-00-FP	COUNTY MACOUPIN	TOTAL SHEETS 141	SHEET NO. 47
	FILE NAME + 2184+em.dgn	DRAWN - TJD	REVISED -					CONTRACT NO. 93574				
	PLOT SCALE + 1/8" = 1' / IN.	CHECKED - NAK	REVISED -					FED. ROAD DIST. NO. ILLINOIS FED. AID PROJECT				
	PLOT DATE + 12/5/2013	DATE - 7/11/2011	REVISED -									
				SCALE:	SHEET NO. OF SHEETS	STA. TO STA.						

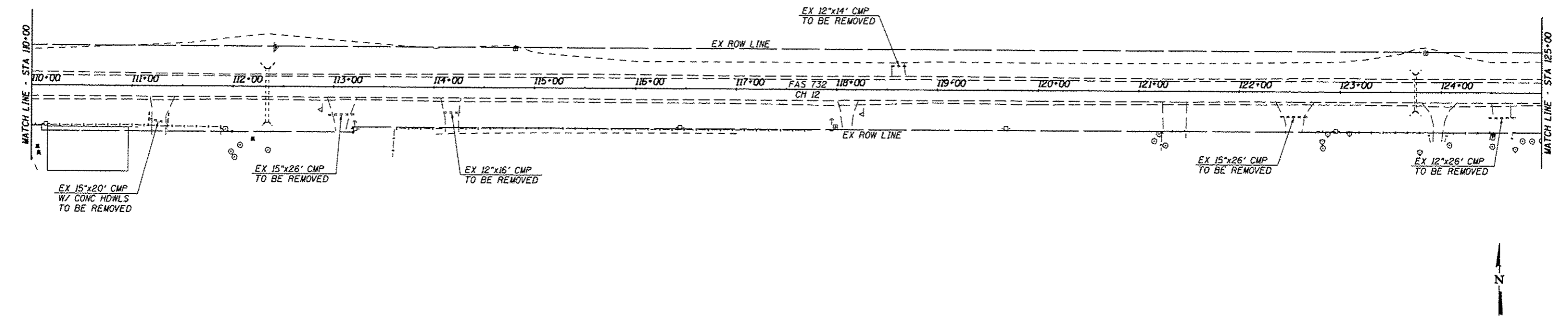
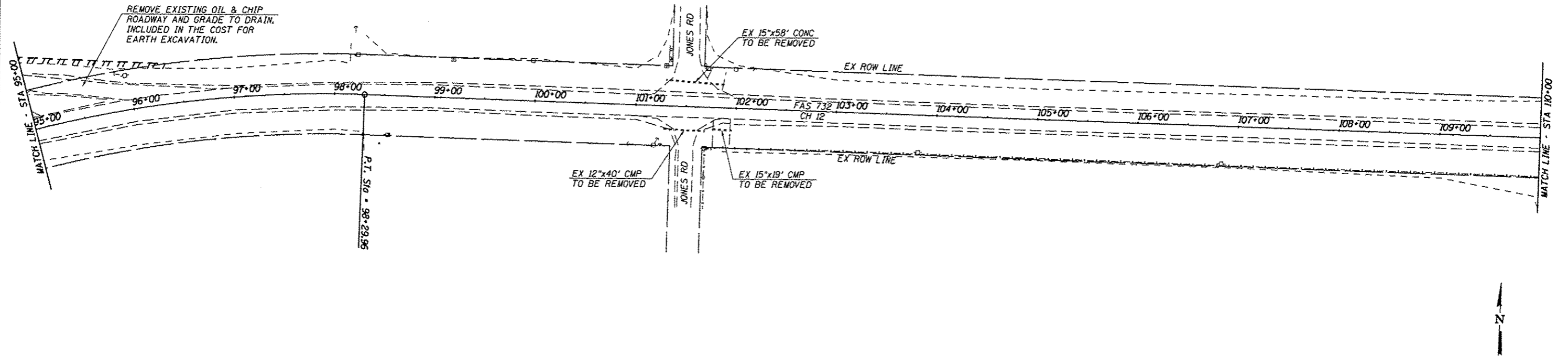

CEC Cummins
Engineering
Corporation
Civil and Structural Engineering

JOB = 2184
FILE NAME = 2184rem.dgn
PLOT SCALE = 1/8" = 1' IN.
PLOT DATE = 11/21/2013

DESIGNED - NAK
DRAWN - TJD
CHECKED - NAK
DATE - 7/11/2011

**MACOUPIN COUNTY
CH 12 IMPROVEMENTS**

REMOVAL PLAN

F.A.S. RTE.	SECTION	COUNTY	TOTAL SHEETS	SHEET NO.
732	01-00079-00-FP	MACOUPIN	141	48
FED. ROAD DIST. NO. ILLINOIS FED. AID PROJECT			CONTRACT NO. 93574	

SCALE: SHEET NO. OF SHEETS STA. TO STA.

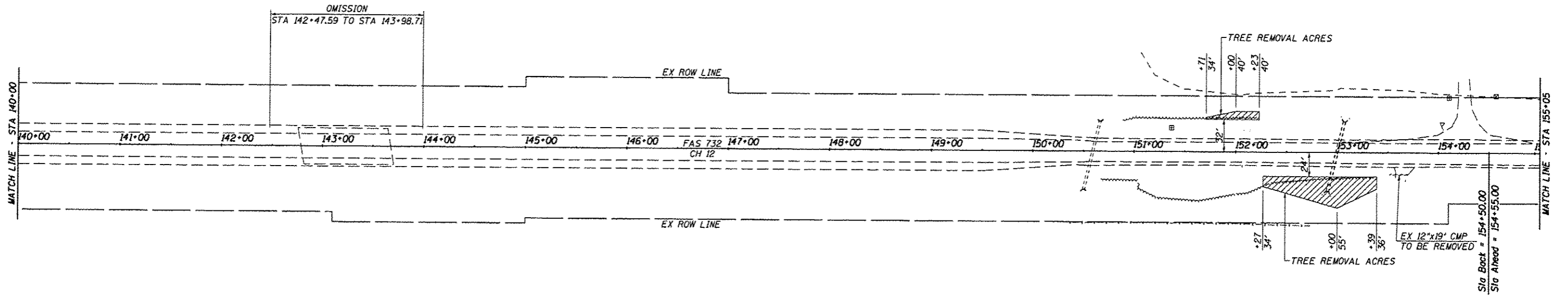
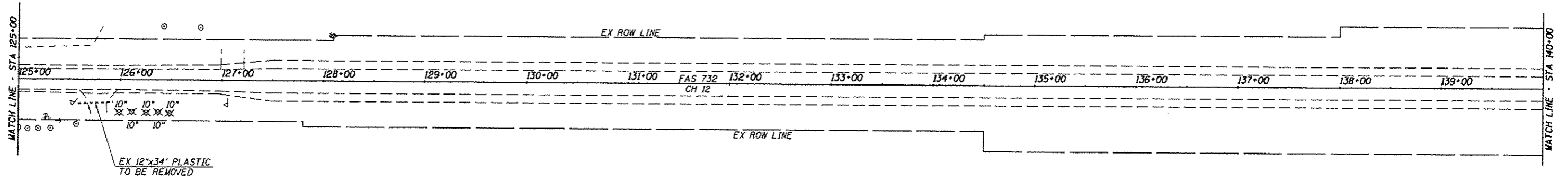

CEC Cummins
Engineering
Corporation
Civil and Structural Engineering

JOB = 2184
FILE NAME = 2184rem.dgn
PLOT SCALE = 1/8" = 1' IN.
PLOT DATE = 11/21/2013

DESIGNED - NAK
DRAWN - TJD
CHECKED - NAK
DATE - 7/11/2011

REVISED -
REVISED -
REVISED -
REVISED -

**MACOUPIN COUNTY
CH 12 IMPROVEMENTS**

REMOVAL PLAN
SCALE: SHEET NO. OF SHEETS STA. TO STA.

F.A.S. RIE. 732	SECTION 01-00079-00-PP	COUNTY MACOUPIN	TOTAL SHEETS 141	SHEET NO. 49
CONTRACT NO. 93574				
FED. ROAD DIST. NO. [ILLINOIS] FED. AID PROJECT				

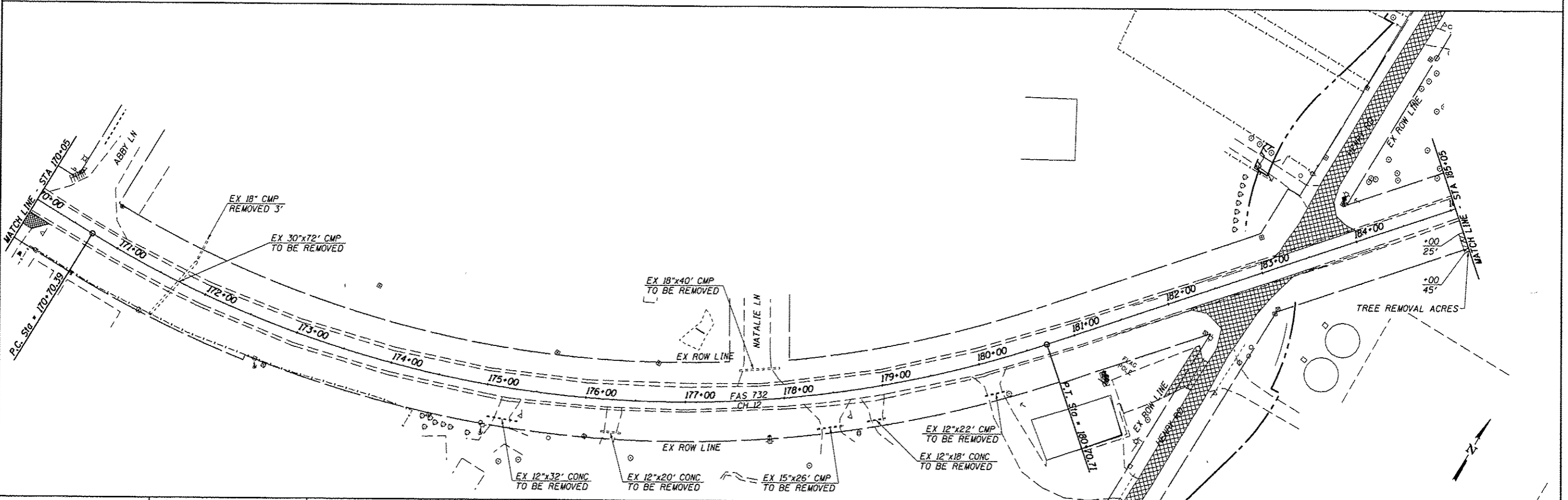
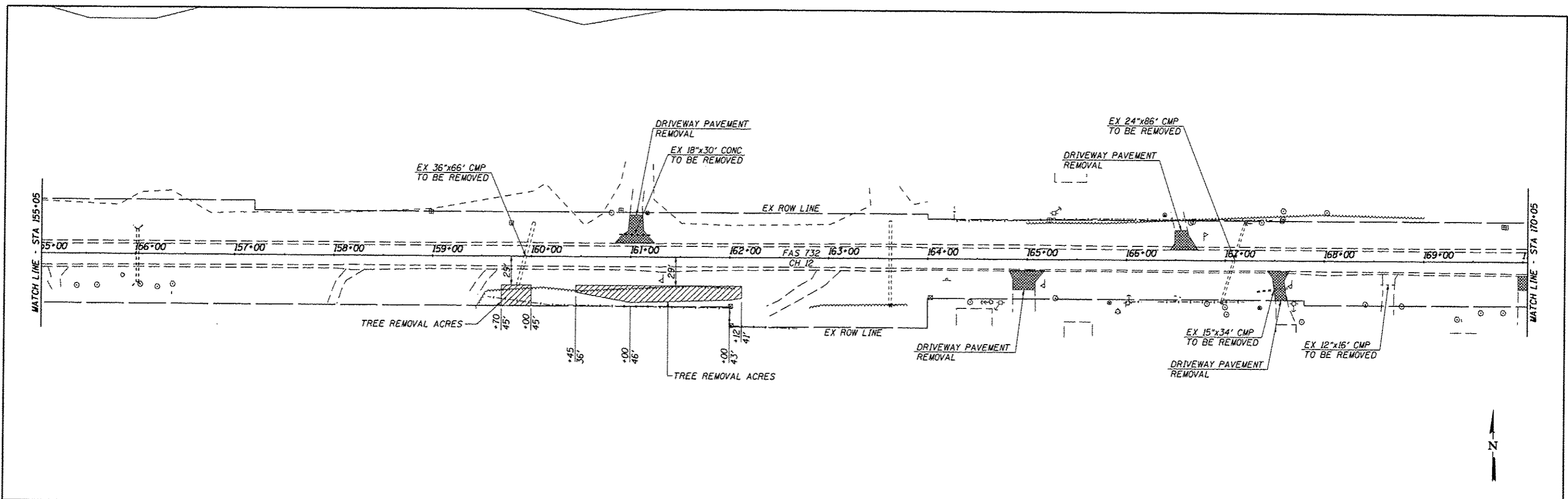

CEC Cummins Engineering Corporation
Civil and Structural Engineering

JOB # 2184
FILE NAME = 2184-am.dgn
PLOT SCALE = 1/8" = 1' IN.
PLOT DATE = 12/5/2013

DESIGNED - NAK
DRAWN - TJD
CHECKED - NAK
DATE - 7/11/2011

REVISED -
REVISED -
REVISED -
REVISED -

**MACOUPIN COUNTY
CH 12 IMPROVEMENTS**

REMOVAL PLAN
SCALE: SHEET NO. OF SHEETS STA. TO STA.

F.A.S. RTE. 732	SECTION 01-00079-00-FP	COUNTY MACOUPIN	TOTAL SHEETS 141	SHEET NO. 50
CONTRACT NO. 93574				
FED. ROAD DIST. NO. [ILLINOIS] FED. AID PROJECT				

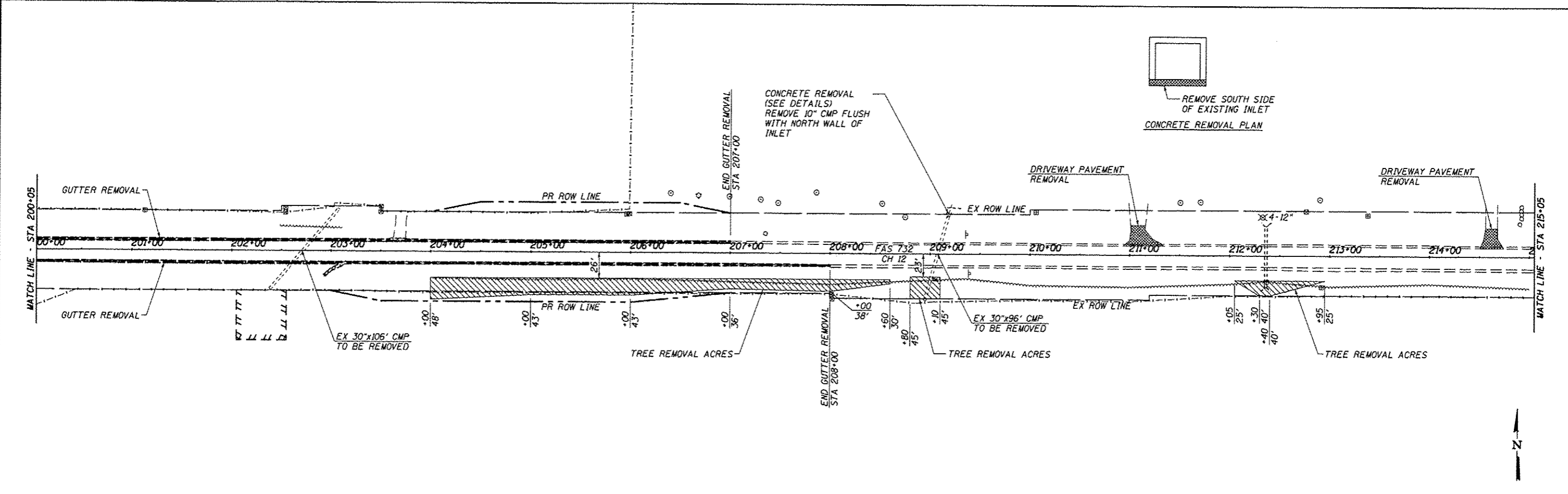
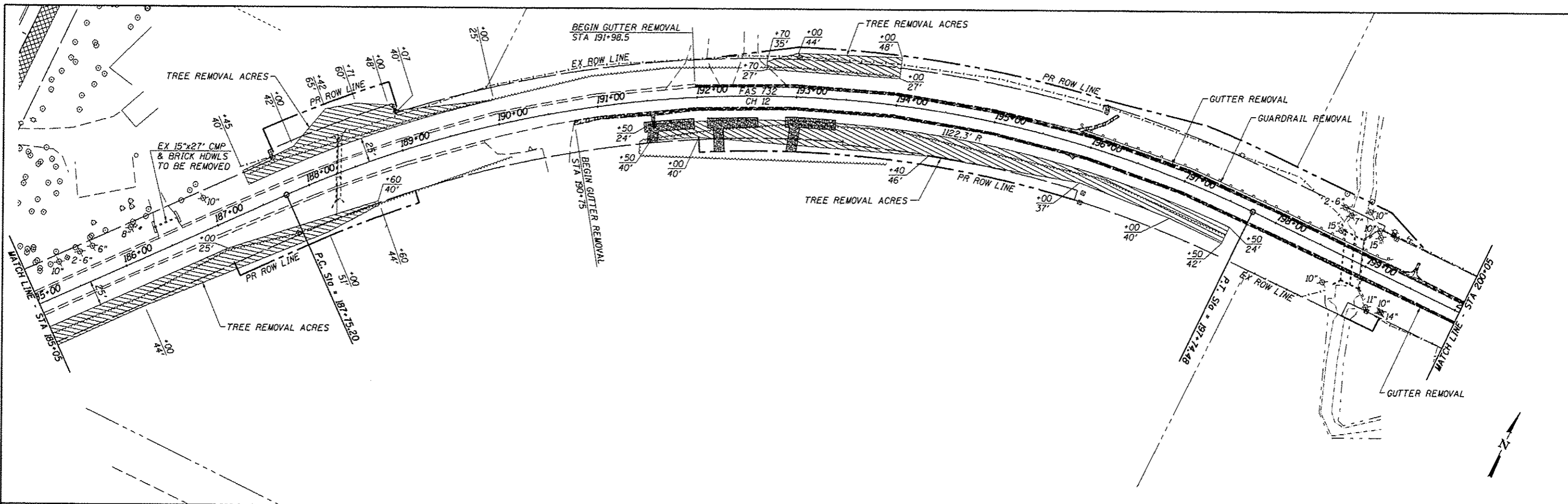

CEC Cummins Engineering Corporation <small>Civil and Structural Engineering</small>	JOB # 2184	DESIGNED - NAK	REVISED -	MACOUPIN COUNTY CH 12 IMPROVEMENTS	REMOVAL PLAN			F.A.S. RTE	SECTION	COUNTY	TOTAL SHEETS	SHEET NO.
	FILE NAME = 2184-rm.dgn	DRAWN - TJD	REVISED -					732	01-00079-00-FP	MACOUPIN	141	51
	PLOT SCALE = 1/8" = 1' IN.	CHECKED - NAK	REVISED -					CONTRACT NO. 93574				
	PLOT DATE = 12/9/2013	DATE = 7/11/2011	REVISED -					ILLINOIS FED. AID PROJECT				
SCALE:		SHEET NO. OF SHEETS		STA. TO STA.								

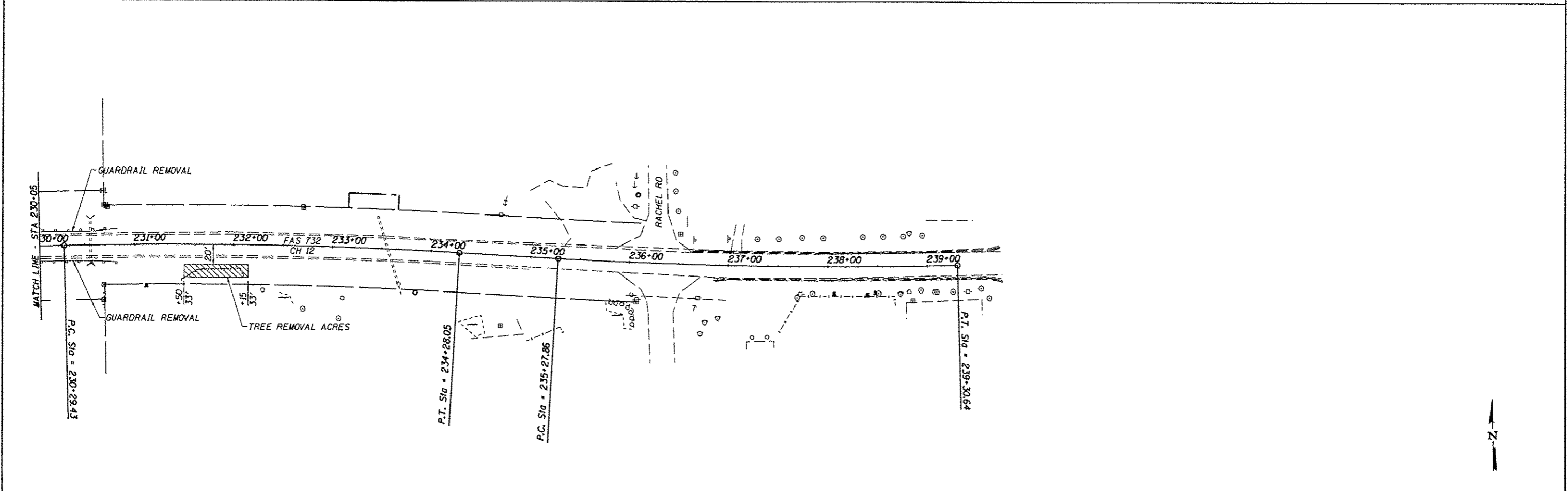
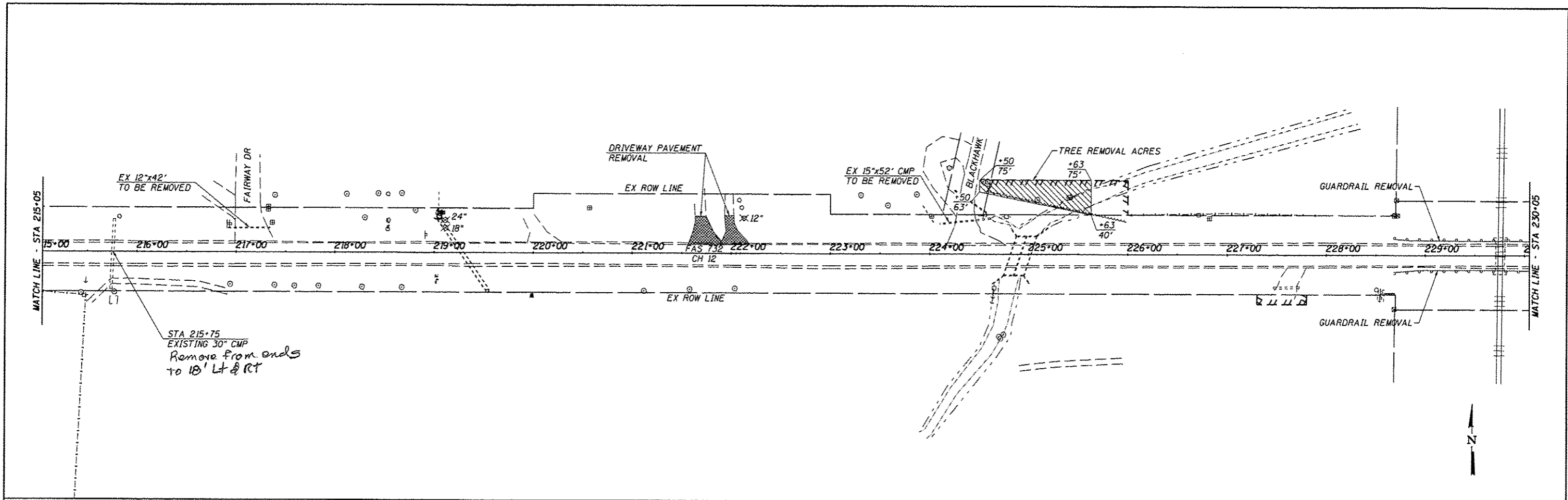



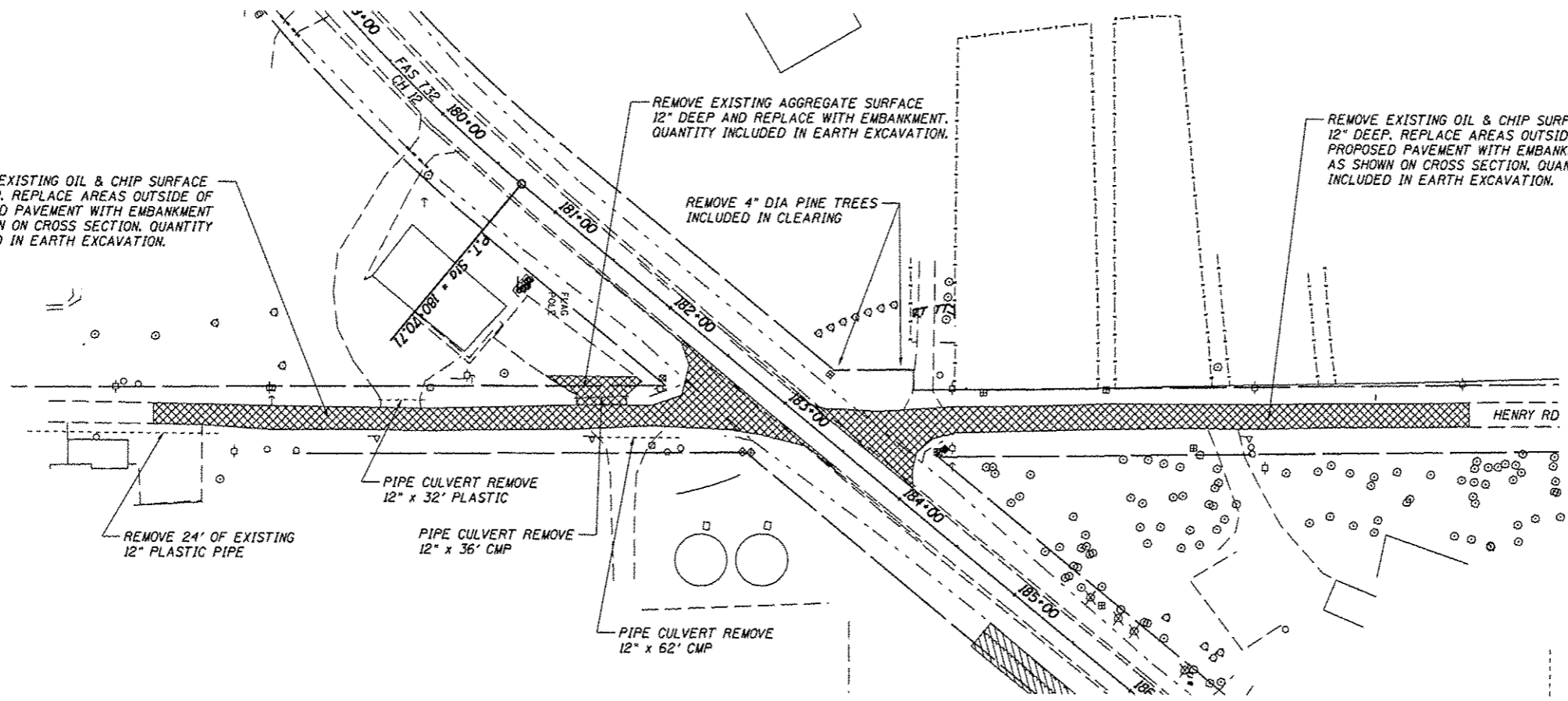

CEC Cummins Engineering Corporation Civil and Structural Engineering	JOB # 2184	DESIGNED - NAK	REVISED -	MACOUPIN COUNTY CH 12 IMPROVEMENTS	REMOVAL PLAN		F.A.S. RTE. 732	SECTION 01-00079-00-FP	COUNTY MACOUPIN	TOTAL SHEETS 141	SHEET NO. 52	
	FILE NAME = 2184rem.dgn	DRAWN - TJD	REVISED -				CONTRACT NO. 93574					
PLOT SCALE = 1/8" = 1' / IN.	CHECKED - NAK	REVISED -	REVISED -	SCALE:	SHEET NO. OF SHEETS	STA. TO STA.	FED. ROAD DIST. NO. ILLINOIS FED. AID PROJECT					
PLOT DATE = 12/5/2013	DATE = 7/11/2011	REVISED -	REVISED -									

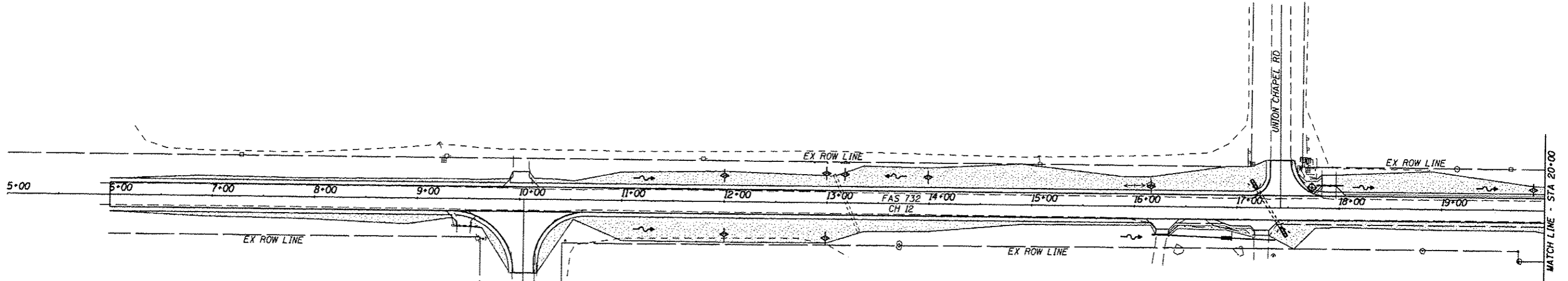
REMOVE EXISTING OIL & CHIP SURFACE
12" DEEP. REPLACE AREAS OUTSIDE OF
PROPOSED PAVEMENT WITH EMBANKMENT
AS SHOWN ON CROSS SECTION. QUANTITY
INCLUDED IN EARTH EXCAVATION.





- LEGEND**
-  INDICATES LIMITS OF SEEDING CL 2 (SPECIAL) AND TEMPORARY EROSION CONTROL SEEDING
 -  TEMPORARY DITCH CHECK
 -  INLET & PIPE PROTECTION
 -  PERIMETER EROSION BARRIER
 -  INDICATES LIMITS OF RIPRAP

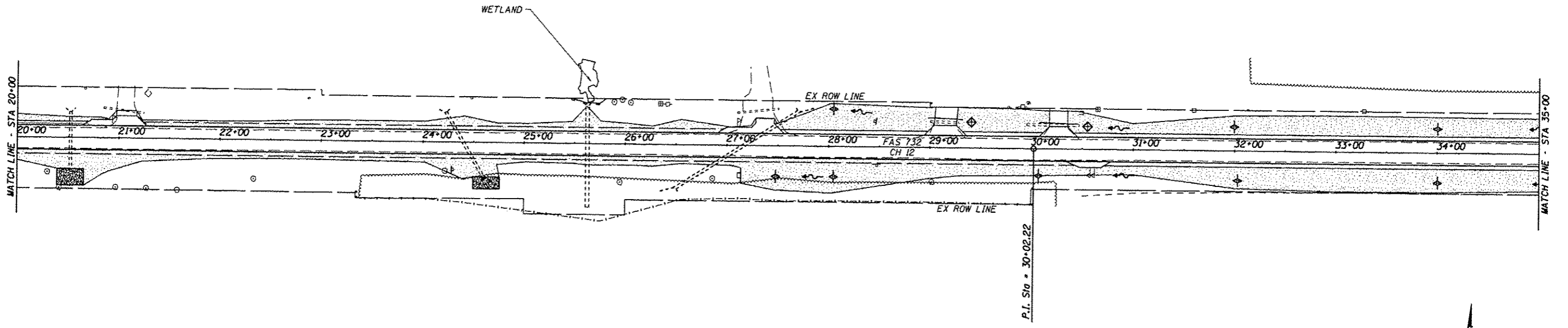

CEC Cummins
Engineering
Corporation
Civil and Structural Engineering

JOB # 2184
FILE NAME = 2184erosion.dgn
PLOT SCALE = 1/80.00" = 1' IN.
PLOT DATE = 11/21/2013

DESIGNED - NAK
DRAWN - TJD
CHECKED - NAK
DATE - 7/11/2011

REVISED -
REVISED -
REVISED -
REVISED -





**MACOUPIN COUNTY
CH 12 IMPROVEMENTS**

EROSION CONTROL PLAN

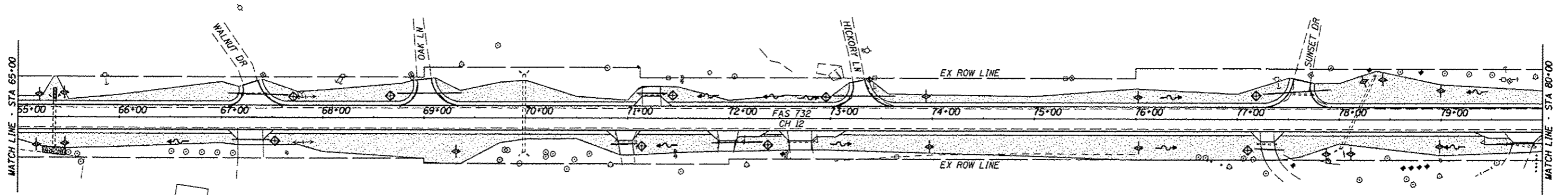
SCALE: SHEET NO. OF SHEETS STA. TO STA.

F.A.S. RTE.	SECTION	COUNTY	TOTAL SHEETS	SHEET NO.
732	01-00079-00-FP	MACOUPIN	141	54
FED. ROAD DIST. NO.			ILLINOIS FED. AID PROJECT	
			CONTRACT NO. 93574	

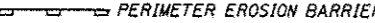

- LEGEND**
-  INDICATES LIMITS OF SEEDING CL 2 (SPECIAL) AND TEMPORARY EROSION CONTROL SEEDING
 -  TEMPORARY DITCH CHECK
 -  INLET & PIPE PROTECTION
 -  PERIMETER EROSION BARRIER
 -  INDICATES LIMITS OF RIPRAP

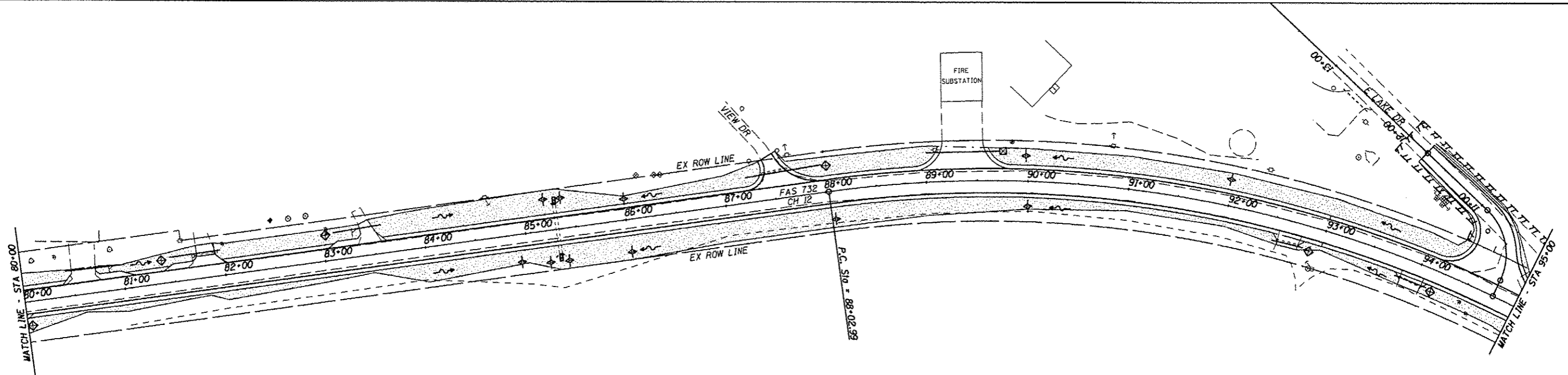

CEC Cummins
Engineering
Corporation
Civil and Structural Engineering

JOB # 2184
FILE NAME = 2184erosion.dgn
PLOT SCALE = 100.00' / IN.
PLOT DATE = 11/21/2013

DESIGNED - NAK
DRAWN - TJD
CHECKED - NAK
DATE - 7/11/2011

REVISED -
REVISED -
REVISED -
REVISED -





**MACOUPIN COUNTY
CH 12 IMPROVEMENTS**

EROSION CONTROL PLAN

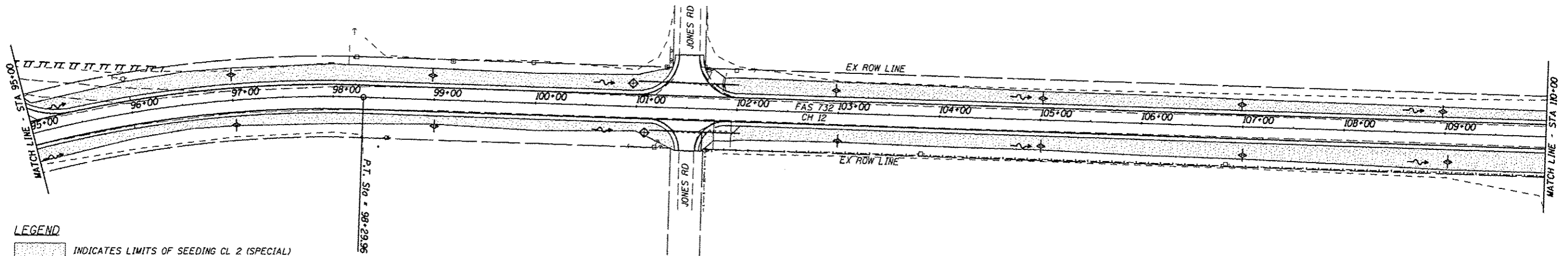
SCALE: SHEET NO. OF SHEETS STA. TO STA.

F.A.S. RTE.	SECTION	COUNTY	TOTAL SHEETS	SHEET NO.
732	01-00079-00-FP	MACOUPIN	141	56
CONTRACT NO. 93574				
FED. ROAD DIST. NO. ILLINOIS FED. AID PROJECT				



- LEGEND**
-  INDICATES LIMITS OF SEEDING CL 2 (SPECIAL) AND TEMPORARY EROSION CONTROL SEEDING
 -  TEMPORARY DITCH CHECK
 -  INLET & PIPE PROTECTION
 -  PERIMETER EROSION BARRIER
 -  INDICATES LIMITS OF RIPRAP

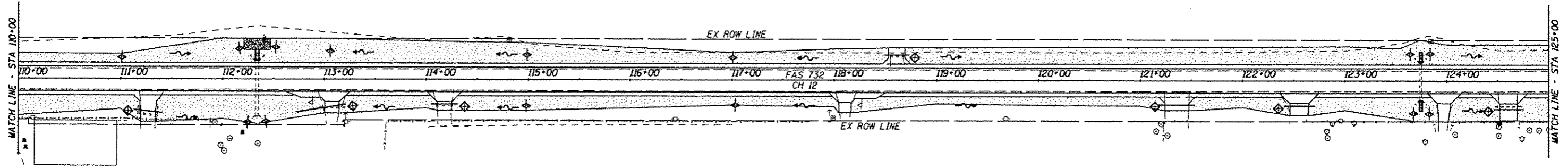

CEC Cummins
Engineering
Corporation
Civil and Structural Engineering

JOB # 2184
FILE NAME # 2184erosion.dgn
PLOT SCALE # 100.00' / IN.
PLOT DATE # 11/21/2013

DESIGNED - NAK
DRAWN - TJD
CHECKED - NAK
DATE - 7/11/2011

REVISED -
REVISED -
REVISED -
REVISED -

**MACOUPIN COUNTY
CH 12 IMPROVEMENTS**



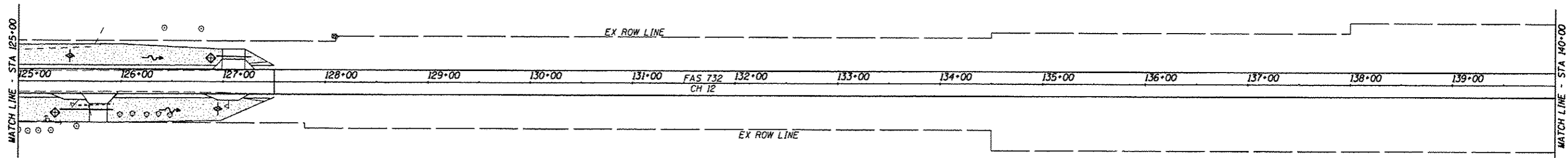

EROSION CONTROL PLAN

SCALE: SHEET NO. OF SHEETS STA. TO STA.

F.A.S. RTE.	SECTION	COUNTY	TOTAL SHEETS	SHEET NO.
732	01-00079-00-FP	MACOUPIN	141	57
FED. ROAD DIST. NO.		ILLINOIS FED. AID PROJECT		
CONTRACT NO. 93574				



LEGEND

-  INDICATES LIMITS OF SEEDING CL 2 (SPECIAL) AND TEMPORARY EROSION CONTROL SEEDING
-  TEMPORARY DITCH CHECK
-  INLET & PIPE PROTECTION
-  PERIMETER EROSION BARRIER
-  INDICATES LIMITS OF RIPRAP

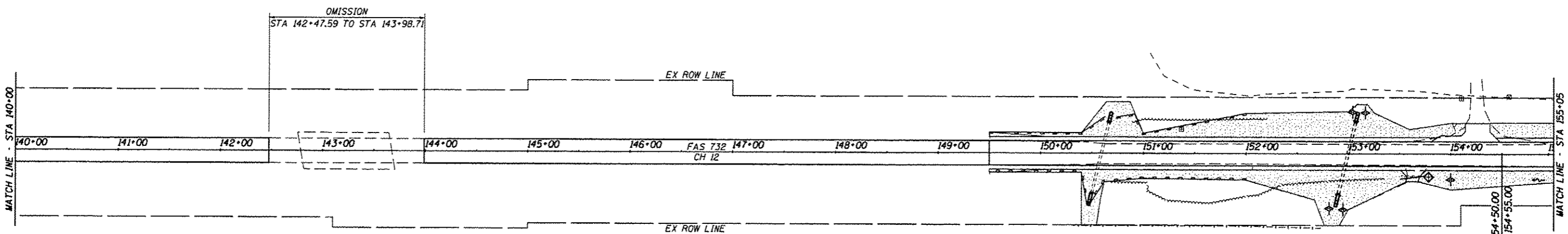

CEC Cummins
Engineering
Corporation
Civil and Structural Engineering

JOB = 2184
FILE NAME = 2184erosion.dgn
PLOT SCALE = 100.00 / IN.
PLOT DATE = 11/21/2013

DESIGNED - NAK
DRAWN - TJD
CHECKED - NAK
DATE - 7/11/2011

REVISED -
REVISED -
REVISED -
REVISED -

**MACOUPIN COUNTY
CH 12 IMPROVEMENTS**

EROSION CONTROL PLAN

SCALE: SHEET NO. OF SHEETS STA. TO STA.

F.A.S. RTE.	SECTION	COUNTY	TOTAL SHEETS	SHEET NO.
732	01-00079-00-FP	MACOUPIN	141	58
FED. ROAD DIST. NO. ILLINOIS FED. AID PROJECT			CONTRACT NO. 93574	

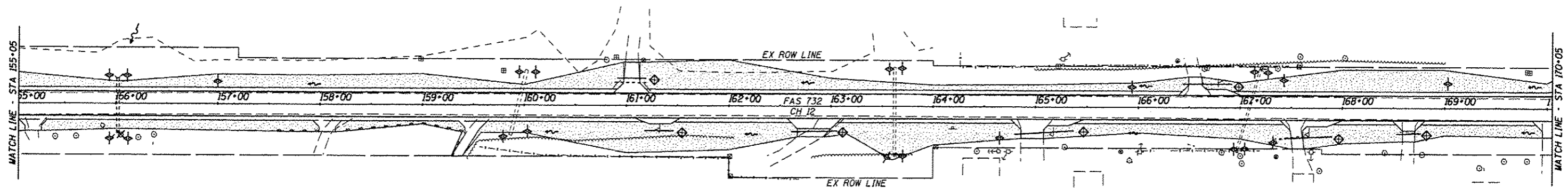

- LEGEND**
- INDICATES LIMITS OF SEEDING CL 2 (SPECIAL) AND TEMPORARY EROSION CONTROL SEEDING
 - TEMPORARY DITCH CHECK
 - INLET & PIPE PROTECTION
 - PERIMETER EROSION BARRIER
 - INDICATES LIMITS OF RIPRAP

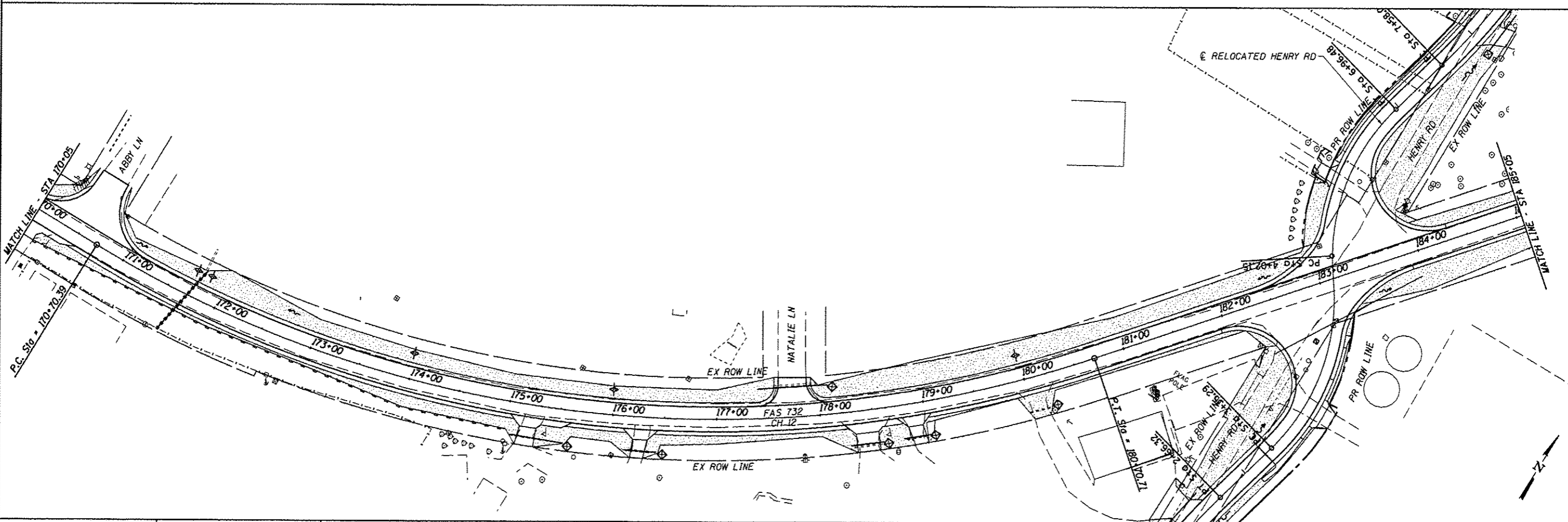

CEC Cummins
Engineering
Corporation
Civil and Structural Engineering

JOB # 2184
FILE NAME # 2184erosion.dgn
PLOT SCALE # 1/8" = 1' IN.
PLOT DATE # 11/21/2013

DESIGNED - NAK
DRAWN - TJD
CHECKED - NAK
DATE - 7/11/2011

REVISED -
REVISED -
REVISED -
REVISED -

**MACOUPIN COUNTY
CH 12 IMPROVEMENTS**

EROSION CONTROL PLAN

SCALE: SHEET NO. OF SHEETS STA. TO STA.

F.A.S. RTE.	SECTION	COUNTY	TOTAL SHEETS	SHEET NO.
732	01-00079-00-FP	MACOUPIN	141	59
FED. ROAD DIST. NO.		ILLINOIS FED. AID PROJECT		
CONTRACT NO. 93574				

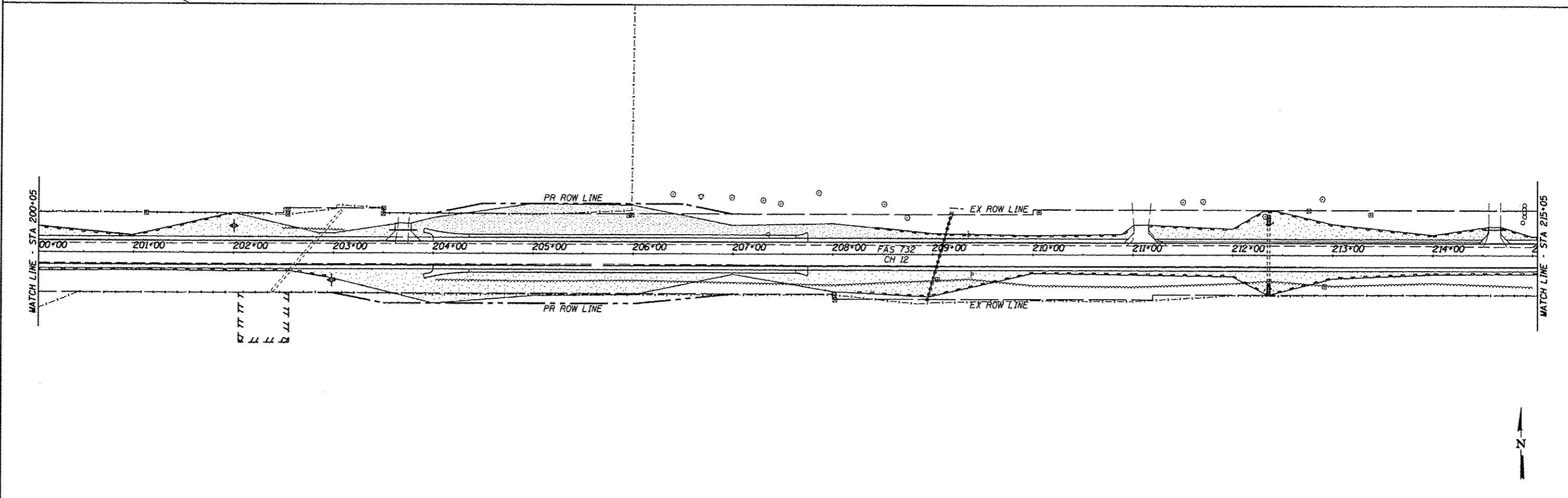
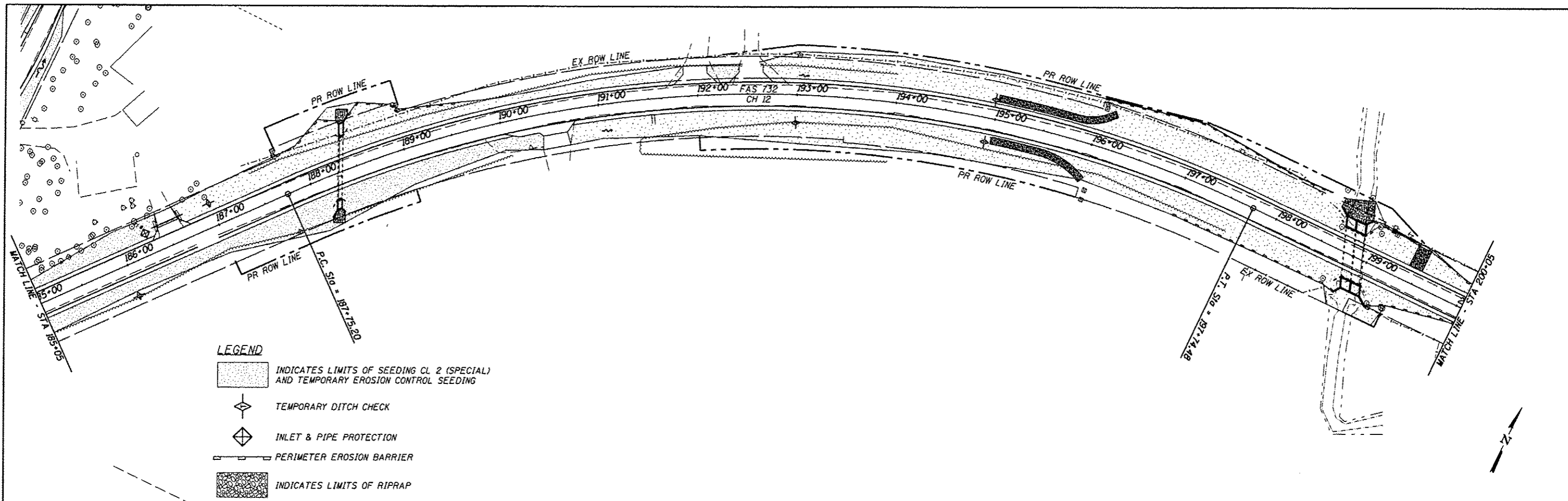

CEC Cummins Engineering Corporation <small>Civil and Structural Engineering</small>	JOB = 2184	DESIGNED - NAK	REVISED -	MACOUPIN COUNTY CH 12 IMPROVEMENTS	EROSION CONTROL PLAN			F.A.S. RTE. 732	SECTION 01-00079-00-FP	COUNTY MACOUPIN	TOTAL SHEETS 141	SHEET NO. 60
	FILE NAME = 2184erosion.dgn	DRAWN - TJD	REVISED -					FED. ROAD DIST. NO.	ILLINOIS FED. AID PROJECT	CONTRACT NO. 93574		
	PLOT SCALE = 1/80.00" / 1"	CHECKED - NAK	REVISED -		SCALE:	SHEET NO. OF SHEETS	STA. TO STA.					
PLOT DATE = 11/21/2013	DATE = 7/11/2011	REVISED -										

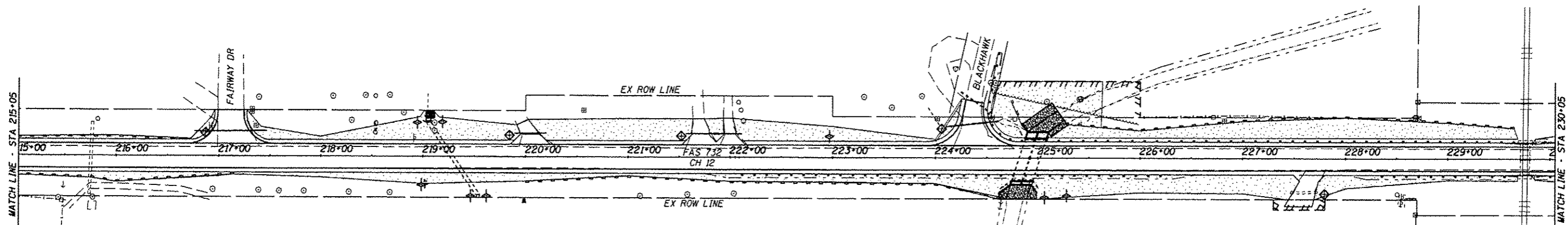

- LEGEND**
- INDICATES LIMITS OF SEEDING CL 2 (SPECIAL) AND TEMPORARY EROSION CONTROL SEEDING
 - TEMPORARY DITCH CHECK
 - INLET & PIPE PROTECTION
 - PERIMETER EROSION BARRIER
 - INDICATES LIMITS OF RIPRAP

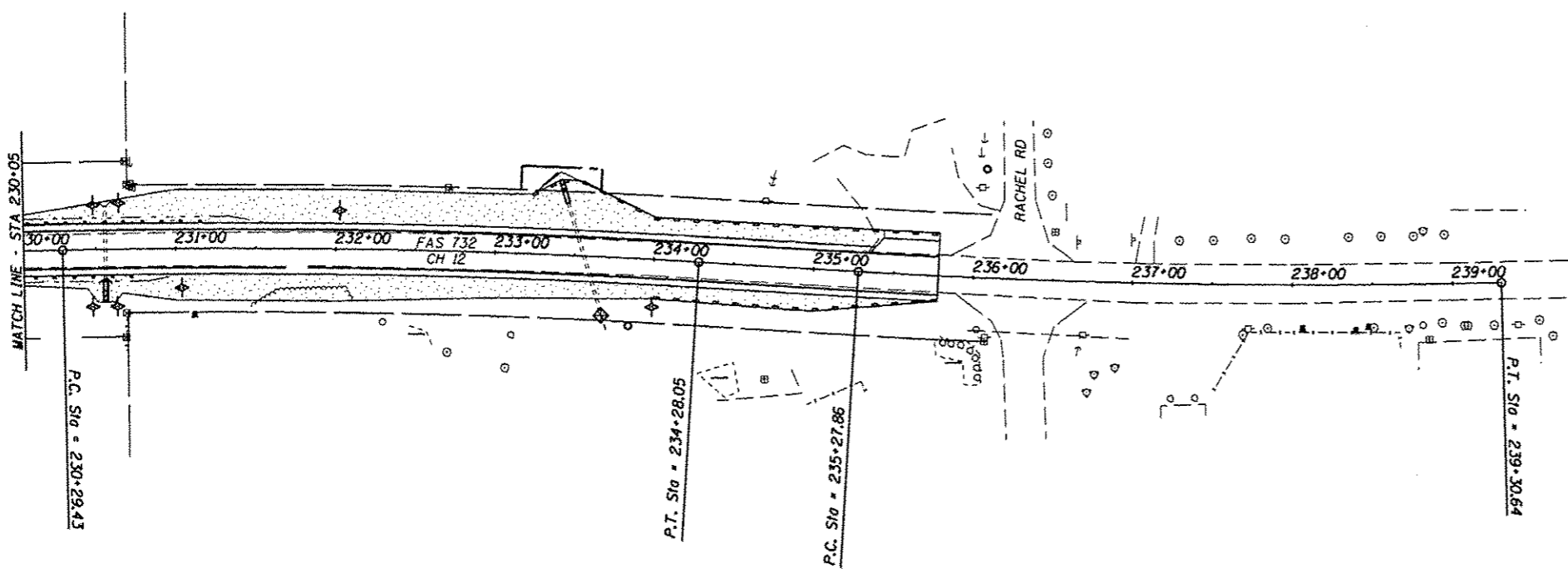

CEC Cummins
Engineering
Corporation
Civil and Structural Engineering

JOB = 2184
FILE NAME = 2184\erosion.dgn
PLOT SCALE = 1/8" = 1' / IN.
PLOT DATE = 11/21/2013

DESIGNED - NAK
DRAWN - TJD
CHECKED - NAK
DATE - 7/11/2011

REVISED -
REVISED -
REVISED -
REVISED -

**MACOUPIN COUNTY
CH 12 IMPROVEMENTS**



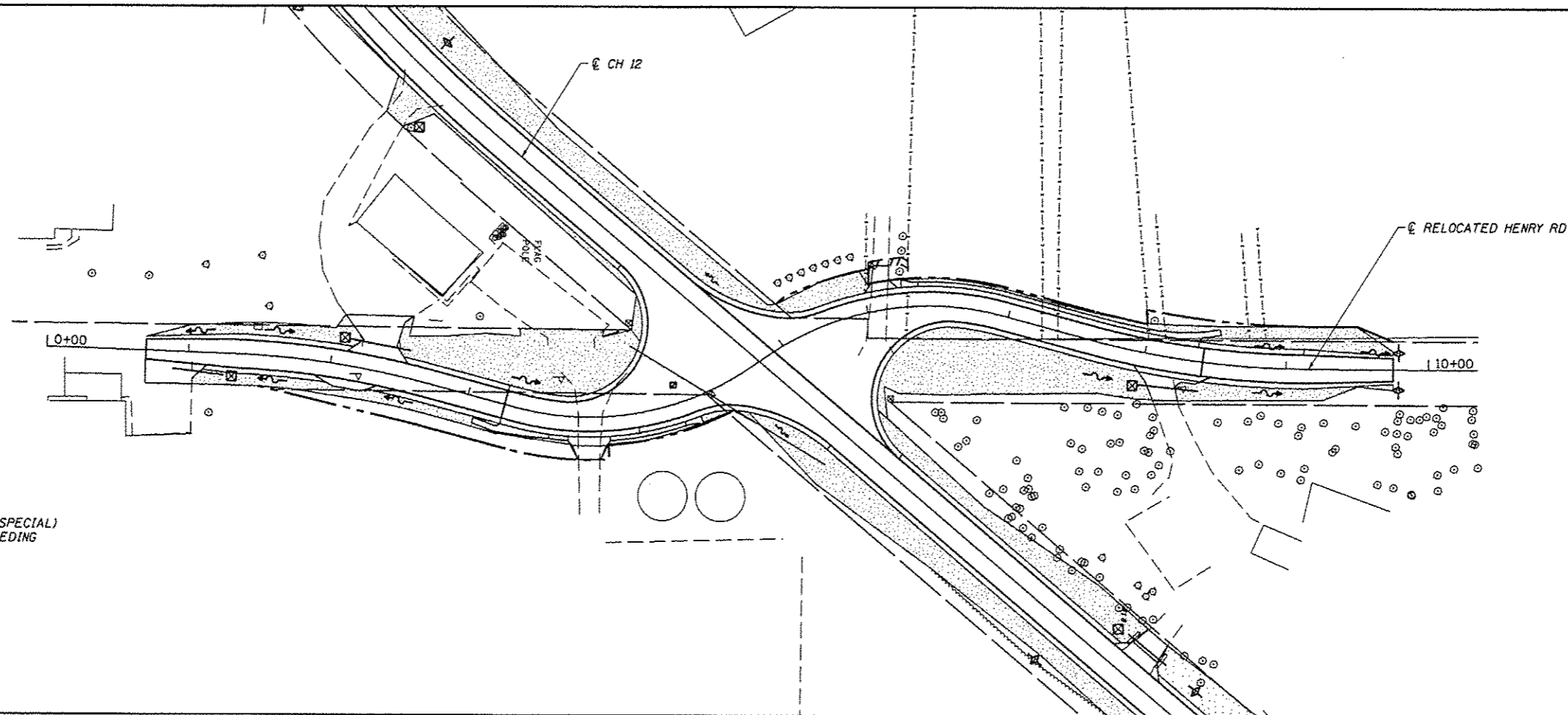

EROSION CONTROL PLAN

SCALE: SHEET NO. OF SHEETS STA. TO STA.

F.A.S. RTE.	SECTION	COUNTY	TOTAL SHEETS	SHEET NO.
732	01-00079-00-FP	MACOUPIN	141	61
CONTRACT NO. 93574				
FED. ROAD DIST. NO. [ILLINOIS] FED. AID PROJECT				



LEGEND

-  INDICATES LIMITS OF SEEDING CL 2 (SPECIAL) AND TEMPORARY EROSION CONTROL SEEDING
-  TEMPORARY DITCH CHECK
-  INLET & PIPE PROTECTION
-  PERIMETER EROSION BARRIER
-  INDICATES LIMITS OF RIPRAP

CEC Cummins
Engineering
Corporation
Civil and Structural Engineering

JOB = 2184
FILE NAME = 2184-er-01.dgn
PLOT SCALE = 100.00' / IN.
PLOT DATE = 11/21/2013

DESIGNED - NAK
DRAWN - TJD
CHECKED - NAK
DATE - 7/11/2011

REVISED -
REVISED -
REVISED -
REVISED -

**MACOUPIN COUNTY
CH 12 IMPROVEMENTS**

**EROSION CONTROL PLAN
HENRY RD**

SCALE: SHEET NO. OF SHEETS STA. TO STA.

F.A.S. RTE.	SECTION	COUNTY	TOTAL SHEETS	SHEET NO.
732	01-00079-00-FP	MACOUPIN	141	62
FED. ROAD DIST. NO. ILLINOIS FED. AID PROJECT			CONTRACT NO. 93574	

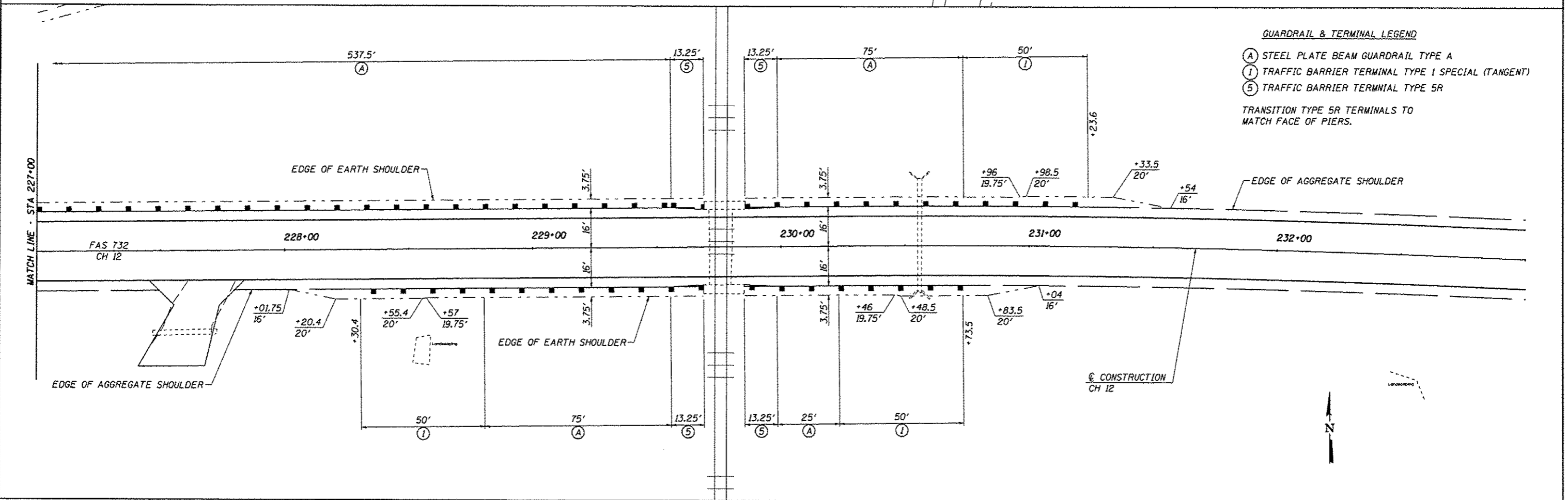
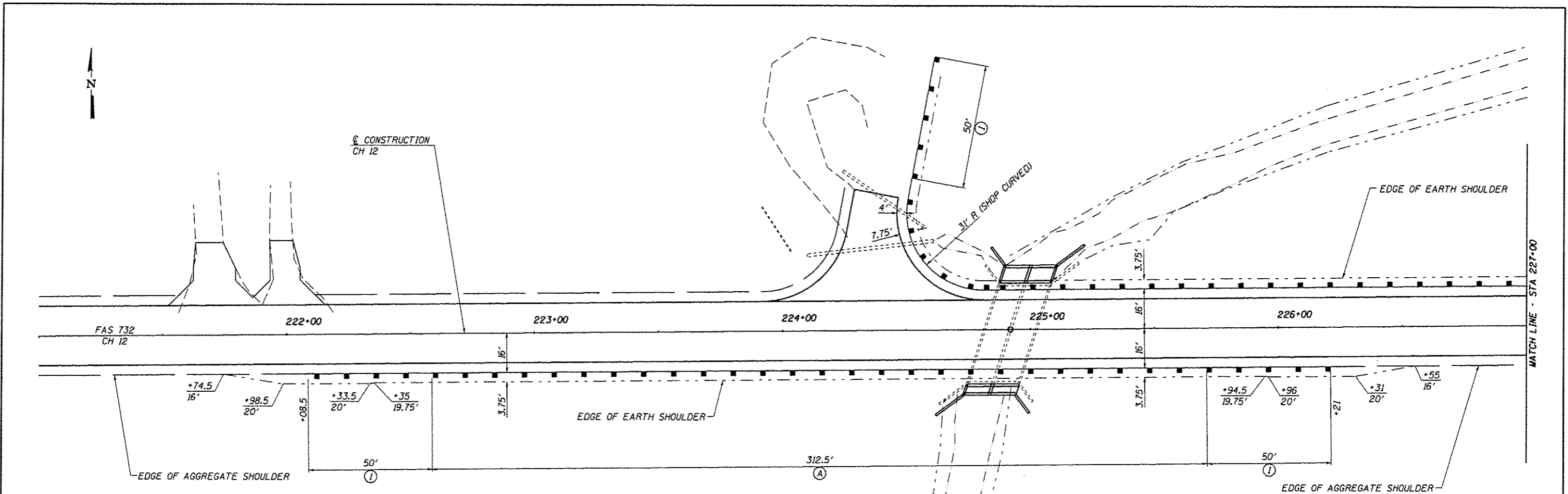

GUARDRAIL & TERMINAL LEGEND

- (A) STEEL PLATE BEAM GUARDRAIL TYPE A
- (I) TRAFFIC BARRIER TERMINAL TYPE I SPECIAL (TANGENT)
- (S) TRAFFIC BARRIER TERMINAL TYPE 5R

TRANSITION TYPE 5R TERMINALS TO MATCH FACE OF PIERS.

CEC Cummins Engineering Corporation
CIVIL and Structural Engineering

JOB # 2184
FILE NAME = 2184-rail.dgn
PLOT SCALE = 40.0000' / 1" = 1/4" = 1/4" = 1/4"
PLOT DATE = 11/21/2013

DESIGNED - NAK
DRAWN - TJD
CHECKED - NAK
DATE - 7/11/2011

REVISED -
REVISED -
REVISED -
REVISED -

**MACOUPIN COUNTY
CH 12 IMPROVEMENTS**

GUARDRAIL PLAN

SCALE: SHEET NO. OF SHEETS STA. TO STA.

F.A.S. RTE.	SECTION	COUNTY	TOTAL SHEETS	SHEET NO.
732	01-00079-00-FP	MACOUPIN	141	63
CONTRACT NO. 93574				
FED. ROAD DIST. NO. ILLINOIS FED. AID PROJECT				

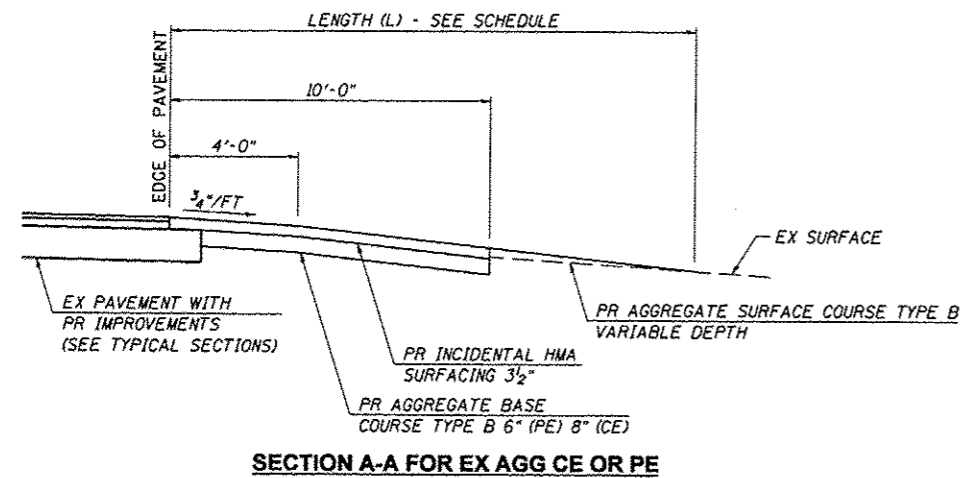

SECTION A-A FOR EX AGG CE OR PE

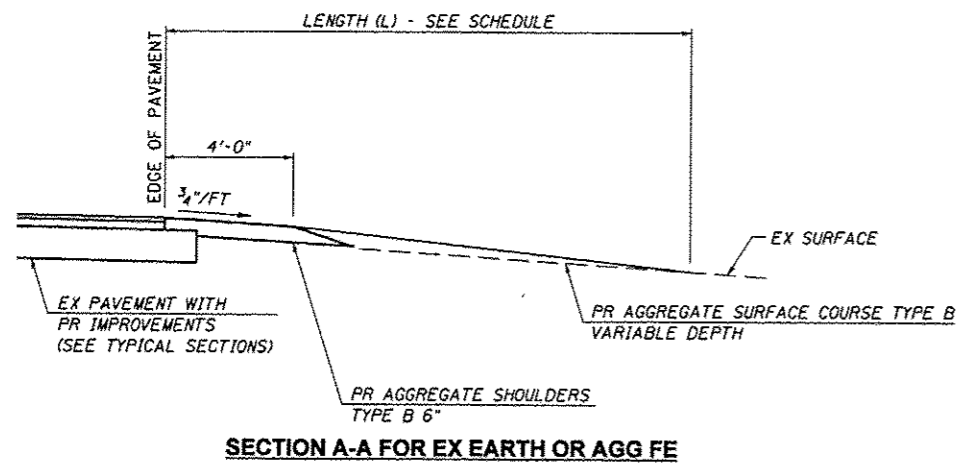

SECTION A-A FOR EX EARTH OR AGG FE

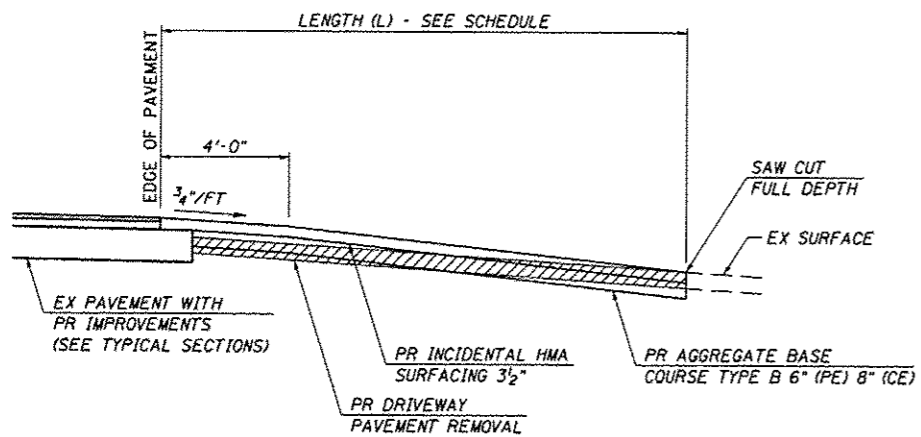

SECTION A-A FOR EX HMA OR CONC CE OR PE

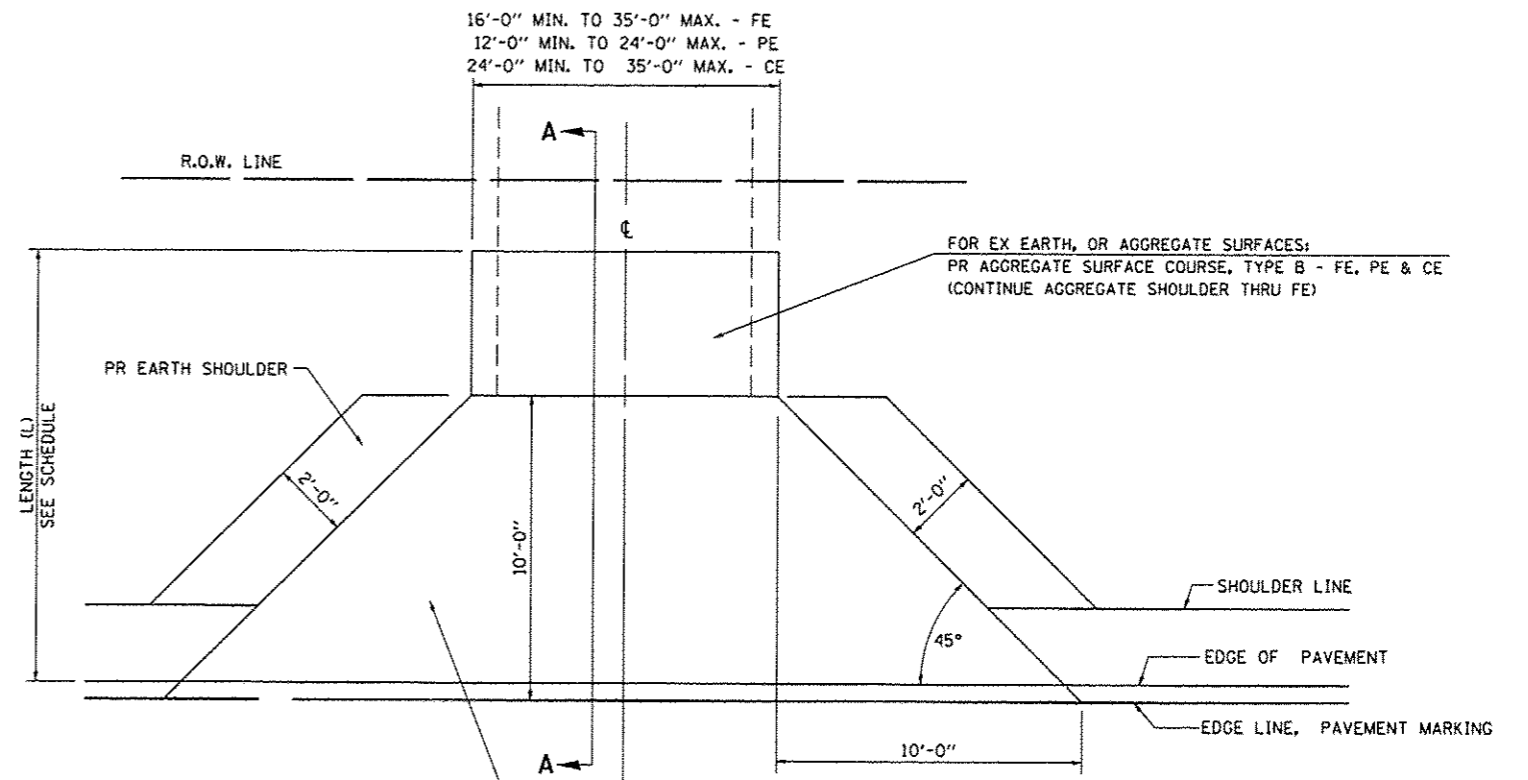

FOR EX EARTH OR AGGREGATE SURFACES:
 PR AGGREGATE SHOULDER THRU - FE
 PR AGG BASE COURSE TYPE B 6" (PE) 8" (CE)
 PR INCIDENTAL BIT. SURFACING 3 1/2" - PE/CE

FOR EX HMA & CONCRETE SURFACES:
 PR DRIVEWAY PAVEMENT REMOVAL
 PR AGG BASE COURSE TYPE B 6" (PE) 8" (CE)
 PR INCIDENTAL HMA SURFACING 3 1/2"

GENERAL NOTES:

THE RESIDENT ENGINEER WILL DETERMINE THE EXACT TYPE OF IMPROVEMENT TO BE COMPLETED FOR ALL ENTRANCES, SIDEROADS AND MAILBOX TURNOUTS ON THIS PROJECT.

THE PLAN DETAILS AND SCHEDULES SHOULD BE USED AS A GUIDE FOR THE ENGINEER TO IMPLEMENT THE FINAL DESIGN. THE ENGINEER MAY DECIDE TO SALVAGE PORTIONS OF THE EXISTING ENTRANCE PAVEMENT STRUCTURE; THEREFORE, REDUCING PAY ITEM QUANTITIES, NO ADDITIONAL PAYMENT WILL BE ALLOWED FOR THIS REDUCTION IN QUANTITIES.

ANY WORK THE ENGINEER REQUIRES WHICH IS NOT COVERED BY A PAY ITEM CONTAINED IN THE PLANS WILL BE PAID FOR IN ACCORDANCE WITH ARTICLE 109.04 OF THE STANDARD SPECIFICATIONS.

HOT-MIX ASPHALT REQUIRED TO CONSTRUCT THE ENTRANCES SHALL BE IN ACCORDANCE WITH THE APPLICABLE PORTIONS OF SECTION 406 AND 408 OF THE STANDARD SPECIFICATIONS AND AS DIRECTED BY THE ENGINEER.

WHEN THE HOT-MIX ASPHALT PROPOSED FOR THE IMPROVEMENT IS THICKER THAN 3 INCHES AND REQUIRE PLACEMENT IN MORE THAN ONE LIFT. THE BOTTOM LIFT(S) SHALL MEET THE REQUIREMENTS OF HOT-MIX ASPHALT BINDER COURSE IN SECTION 406 OF THE STANDARD SPECIFICATIONS AND THE TOP LIFT OF 1 1/2 INCHES SHALL MEET THE REQUIREMENTS OF HOT-MIX ASPHALT SURFACE COURSE.

THIS WORK WILL BE PAID FOR IN ACCORDANCE WITH SECTIONS 351, 358, 408, 423 AND 440 OF THE STANDARD SPECIFICATIONS.

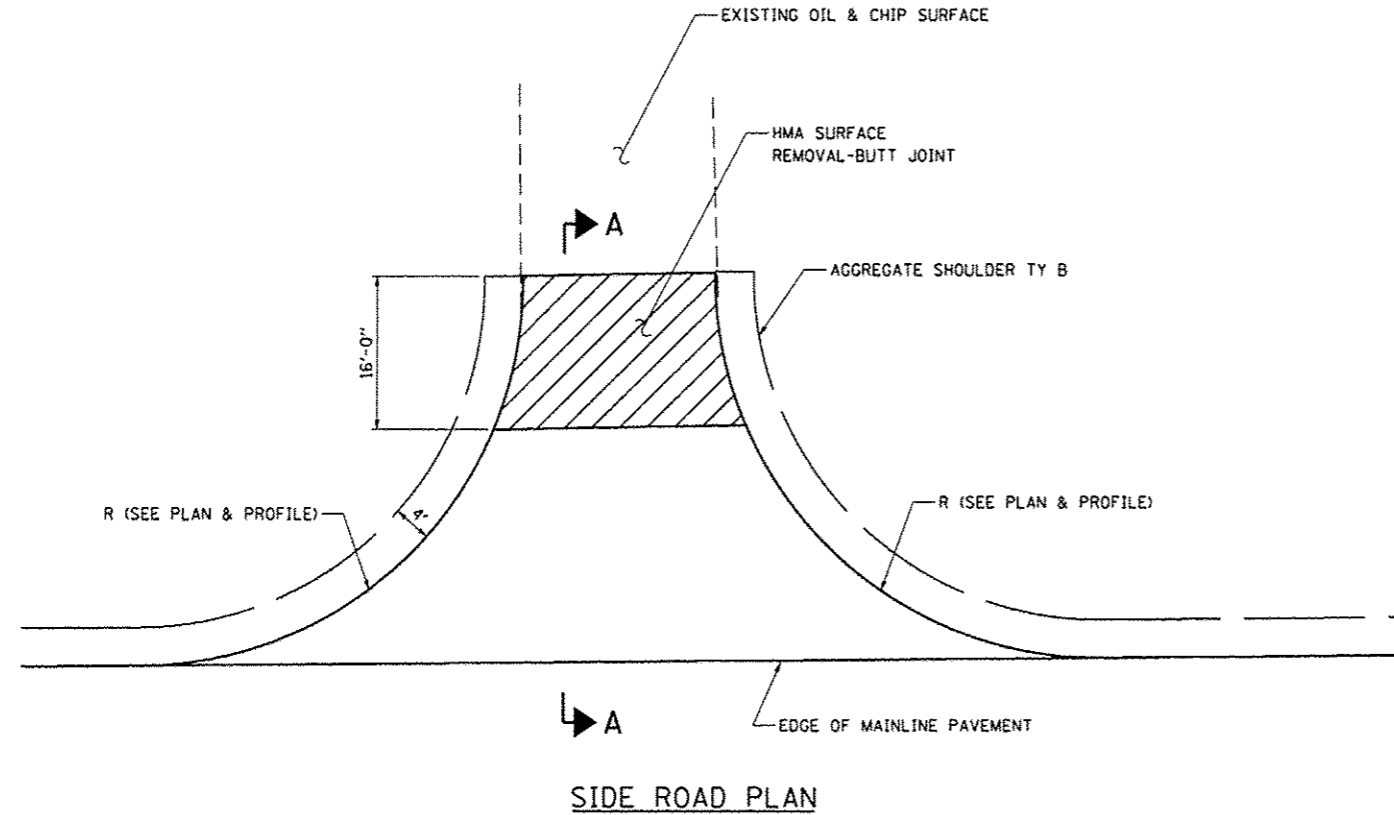

SEE SHEET 1 OF 2 FOR
GENERAL NOTES

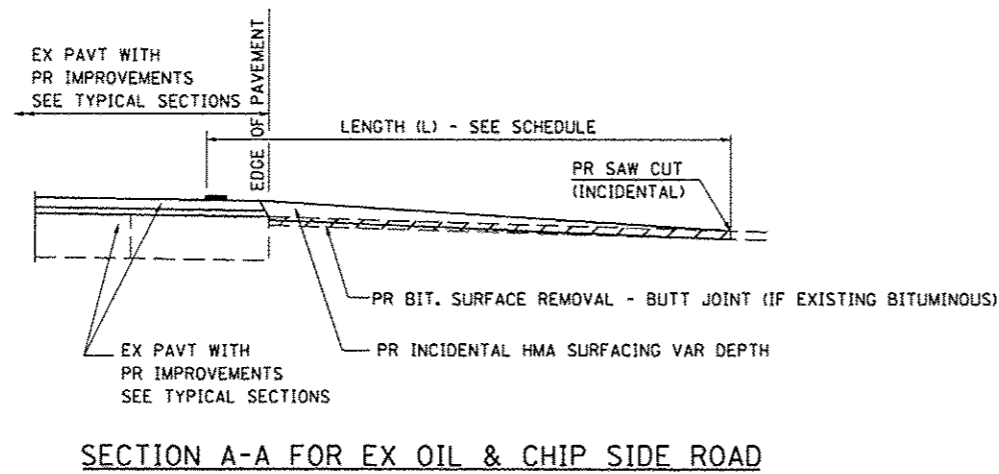

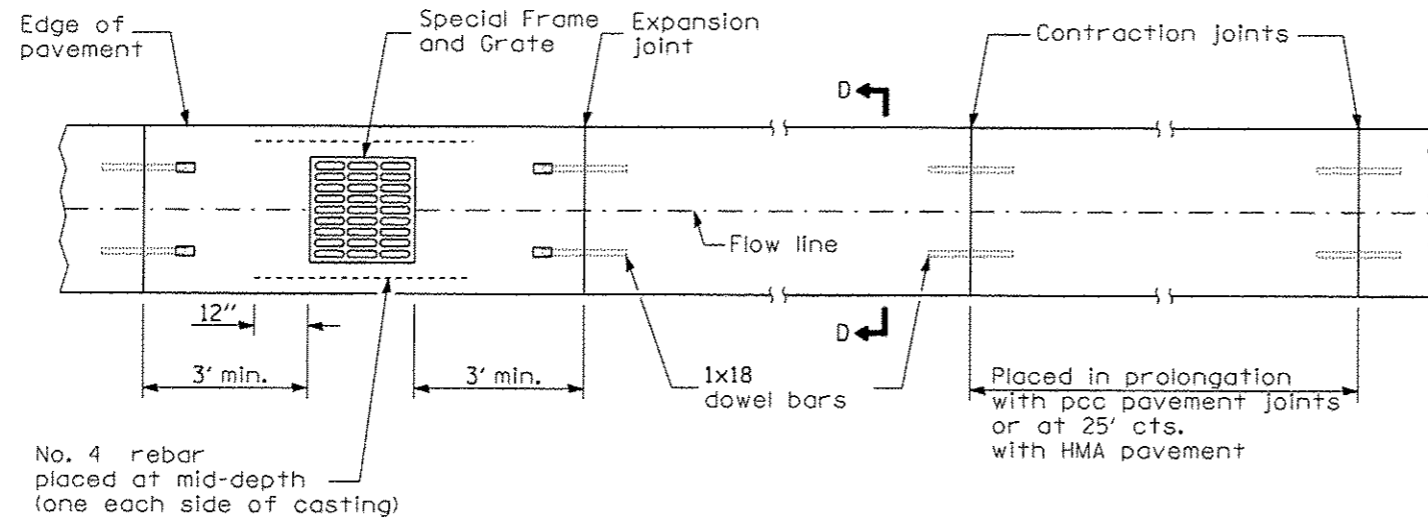

PLAN

TYPE A GUTTER (MODIFIED)

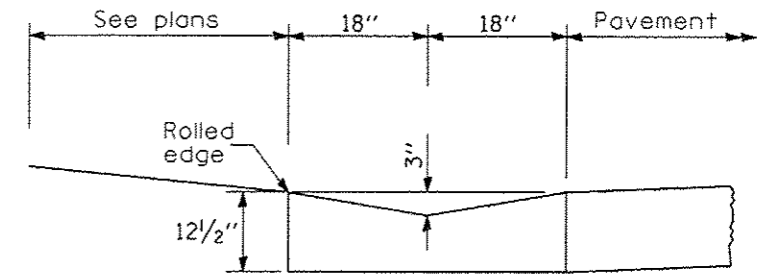

SECTION D-D

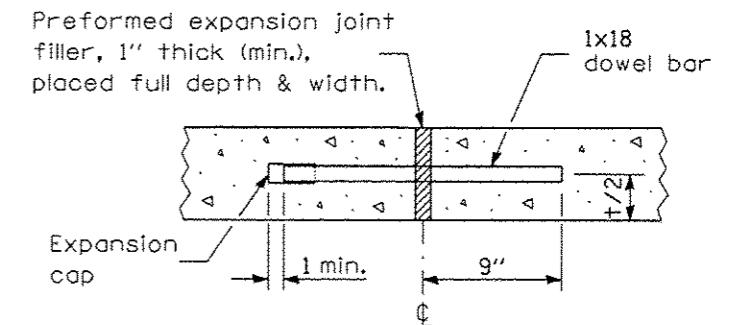

EXPANSION JOINT

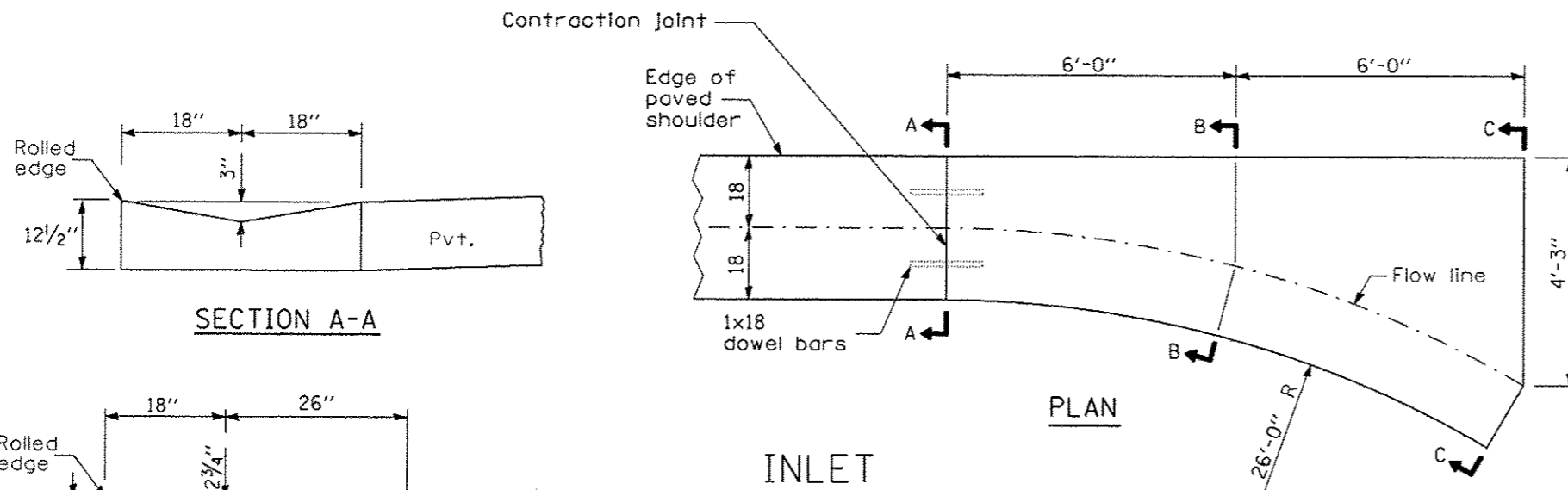

PLAN

INLET

QUANTITY OF CONCRETE
Section A-A to C-C
1.73 cu. yd.

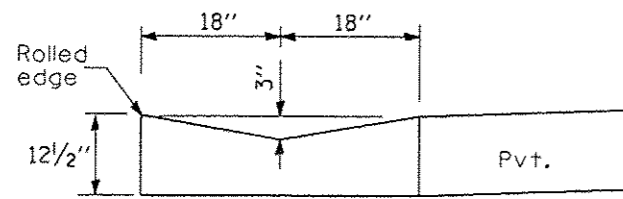

SECTION A-A

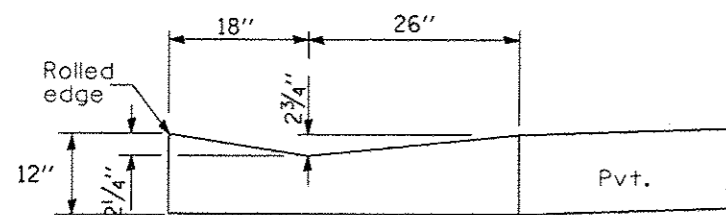

SECTION B-B

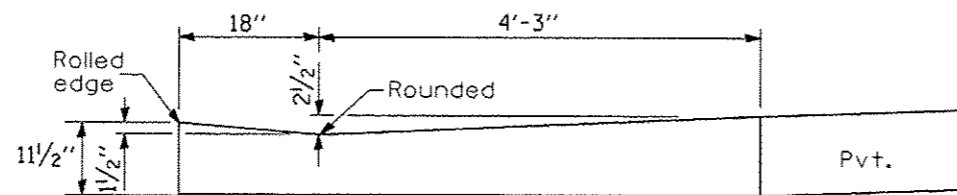

SECTION C-C

QUANTITIES OF CONCRETE

All Entrances:

Section B-B to C-C = 0.19 cu. yd./ft.

Section (A-A to B-B) + (C-C to D-D) = 0.44 cu. yd.

NOTE

Welded wire fabric shall be installed at mid-depth from Section A-A to D-D. (58 lbs./100 sq. ft.)

Welded wire fabric will not be paid for separately but shall be included in the cost for CLASS SI CONCRETE (OUTLET).

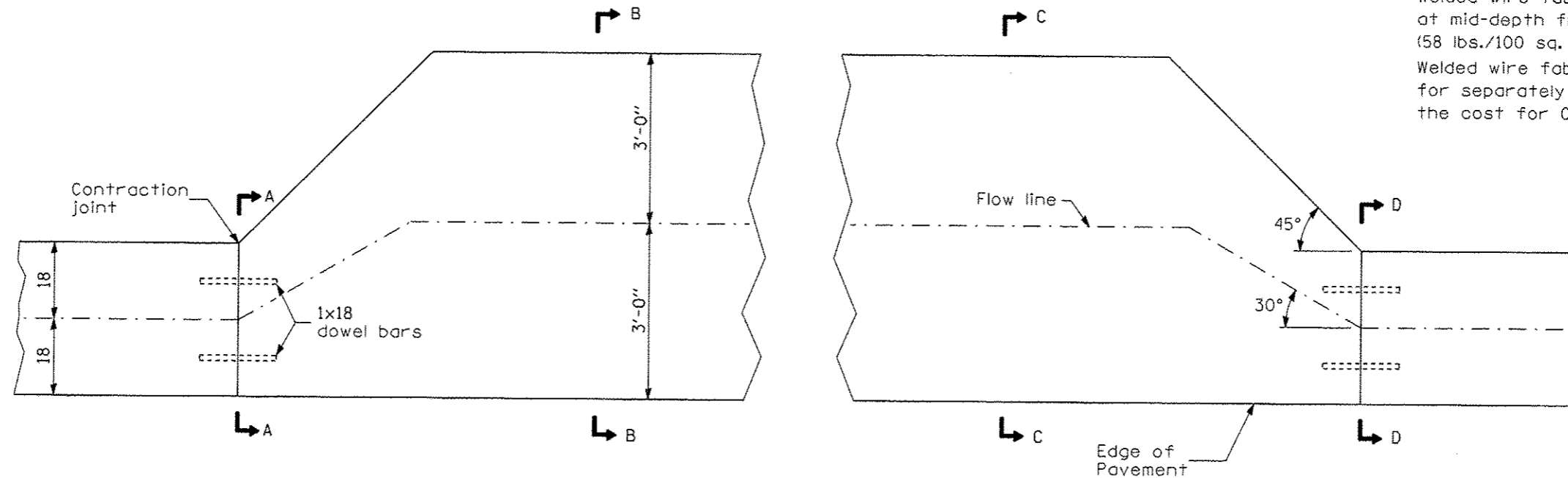

PLAN

ENTRANCE

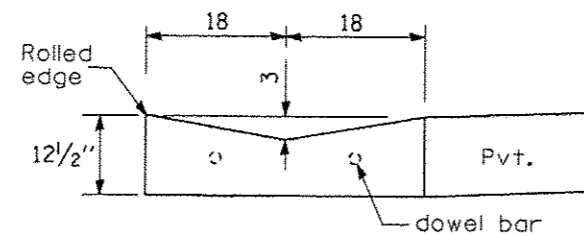

SECTIONS A-A & D-D

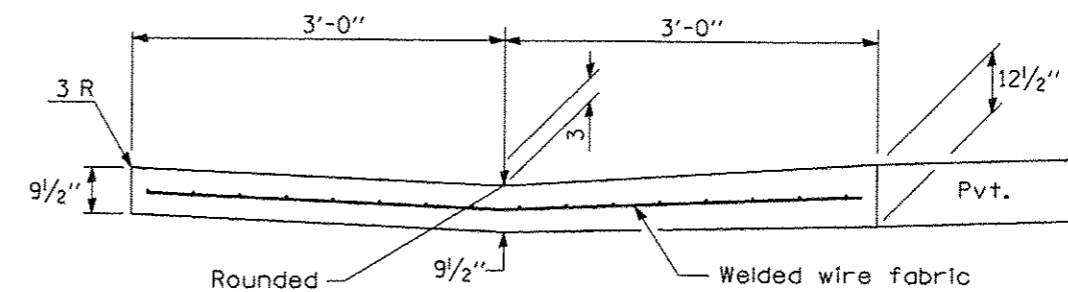

SECTIONS B-B & C-C

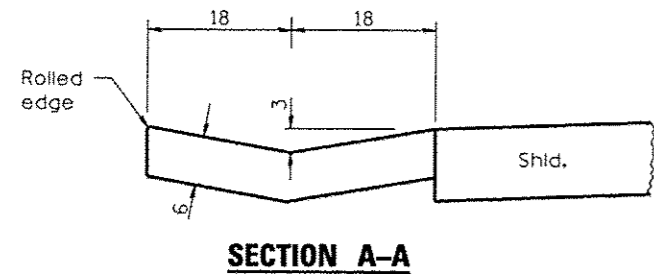

SECTION A-A

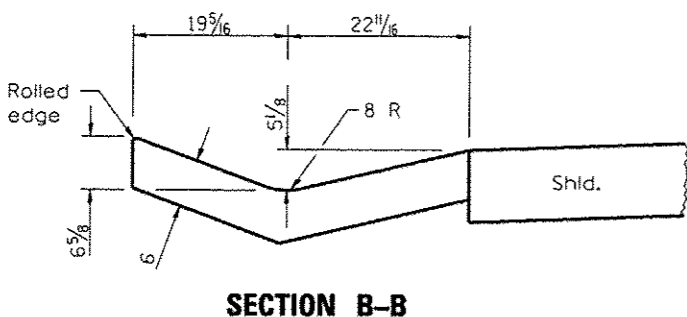

SECTION B-B

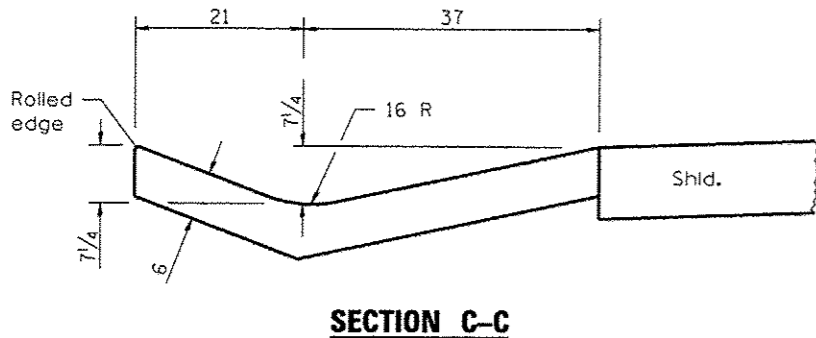

SECTION C-C

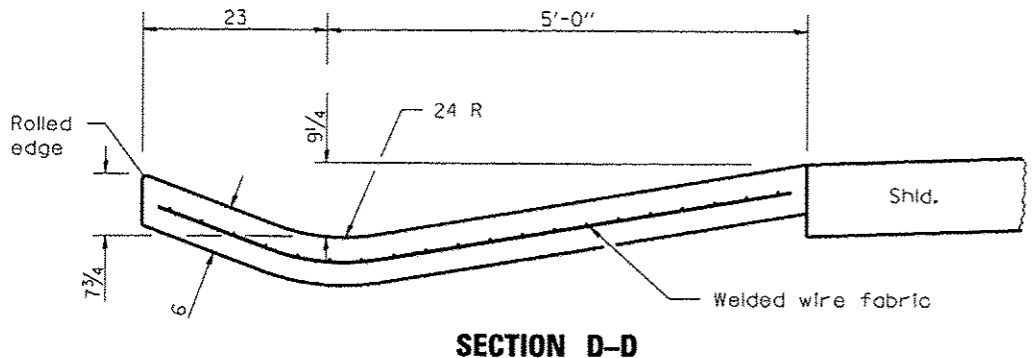

SECTION D-D

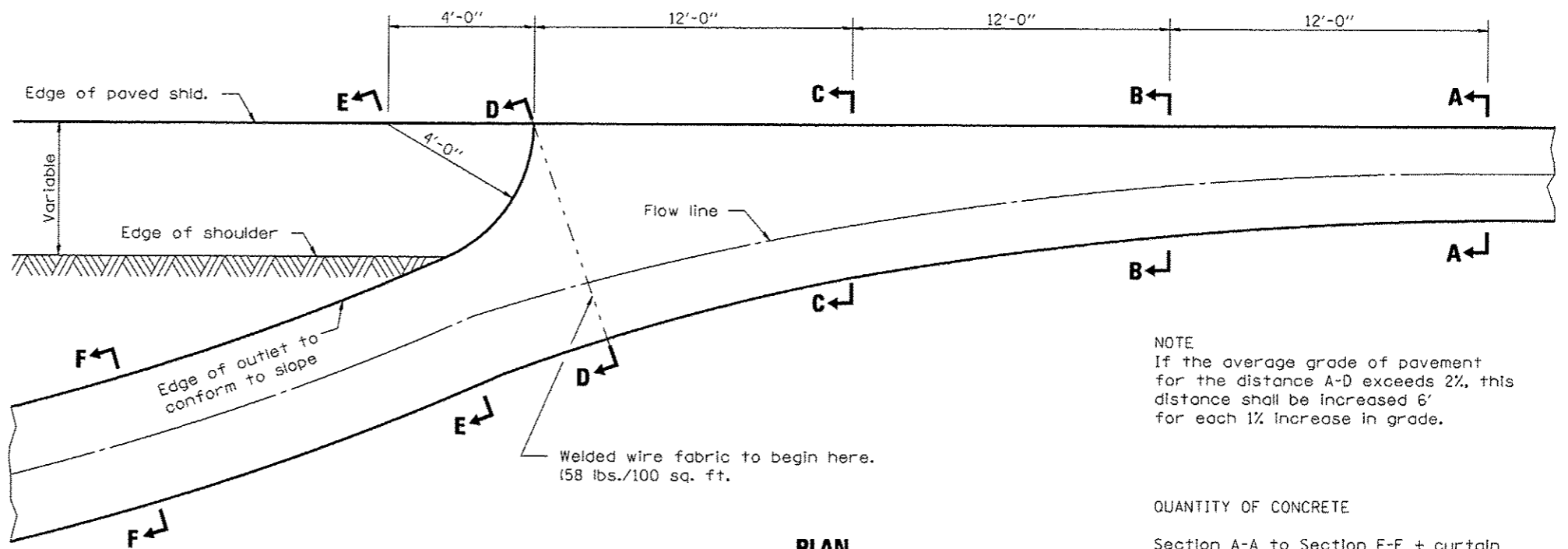

PLAN

NOTE
If the average grade of pavement for the distance A-D exceeds 2%, this distance shall be increased 6' for each 1% increase in grade.

QUANTITY OF CONCRETE
Section A-A to Section E-E + curtain wall = 3.53 cu. yd. of concrete.
Section F-F = 0.079 cu. yd./ft.

OUTLET

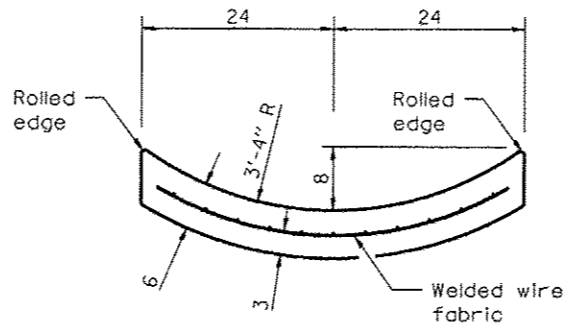

SECTION F-F

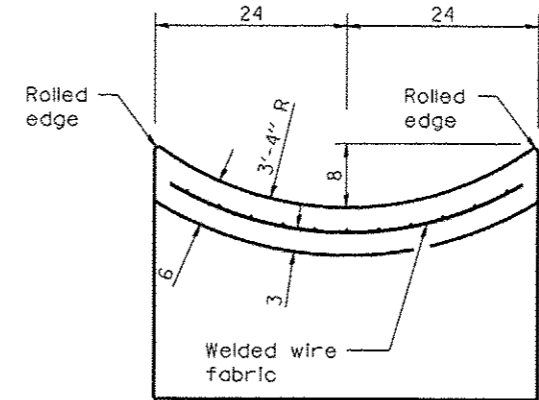

SECTIONS AT END OF OUTLET

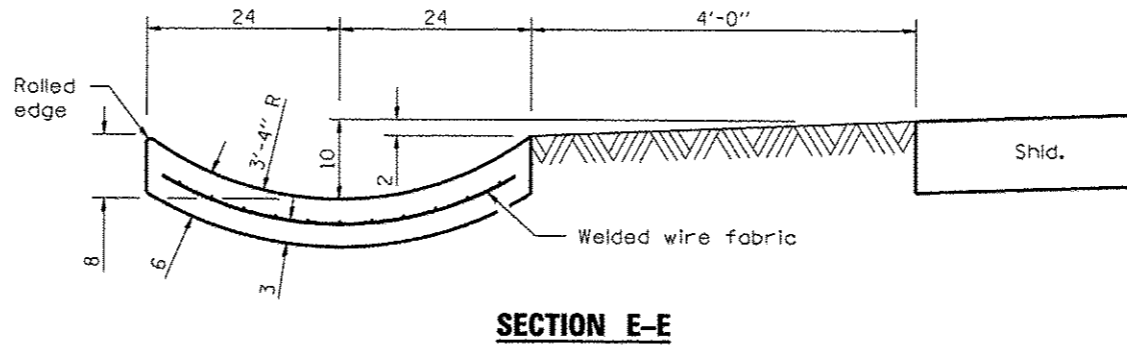
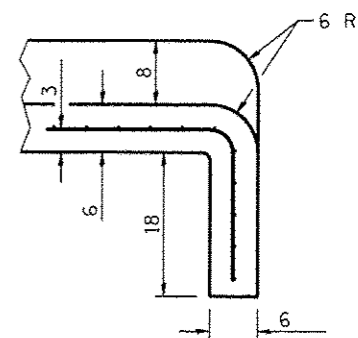

SECTION E-E

CEC Cummins Engineering Corporation Civil and Structural Engineering	JOB # 2184	DESIGNED - NAK	REVISED -	MACOUPIN COUNTY CH 12 IMPROVEMENTS	TYPE A GUTTER (SPECIAL) (INLET, OUTLET & ENTRANCE)			F.A.S. RTE. 732	SECTION 01-00079-00-FP	COUNTY MACOUPIN	TOTAL SHEETS 141	SHEET NO. 68
	FILE NAME * 22450utter.dgn	DRAWN - TJD	REVISED -		SCALE:	SHEET NO.	OF SHEETS	STA.	TO STA.	FED. ROAD DIST. NO.	ILLINOIS FED. AID PROJECT	CONTRACT NO. 93574
	PLOT SCALE = 2.863 Ft. / IN.	CHECKED - NAK	REVISED -									
	PLOT DATE = 11/21/2013	DATE - 7/27/2010	REVISED -									

DETAIL OF PRECAST CONCRETE BOX CULVERTS AND END SECTIONS

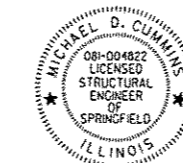
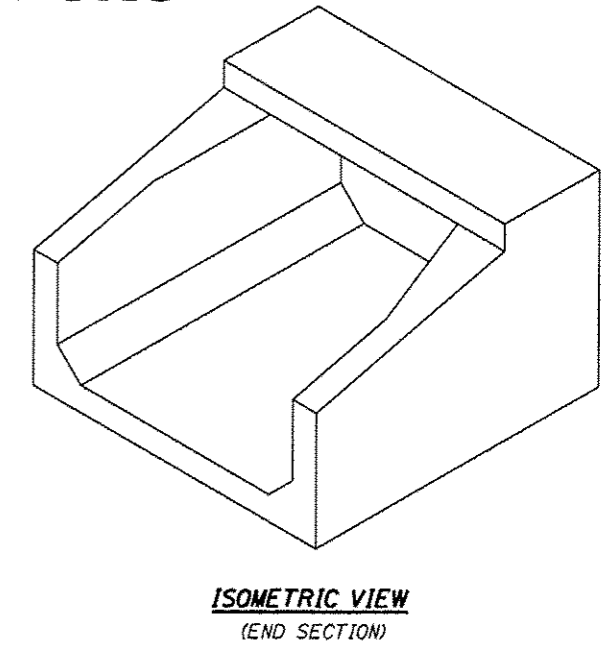
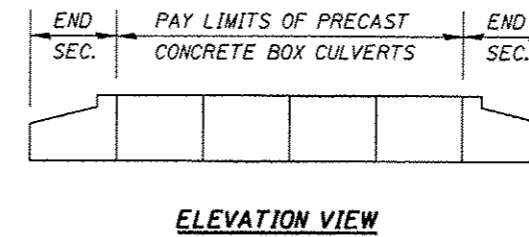
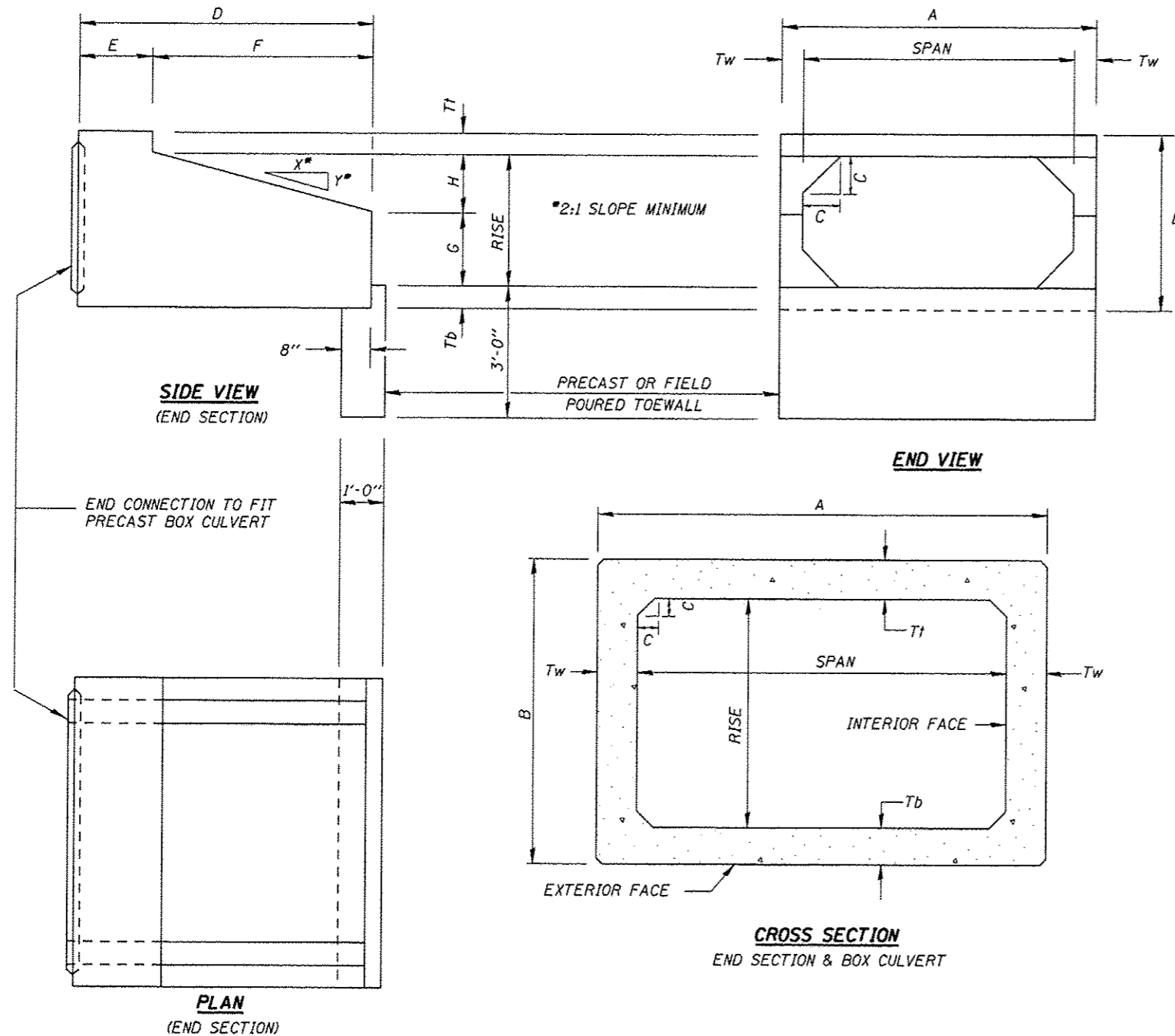

Michael D. Cummins 11/25/13
 (Expires 11/30/2014)

DESIGN SPECIFICATIONS
 2010 AASHTO with 2010 & 2011 Interims
LOADING HL-93

DESIGN STRESSES (PRECAST)
 $f'_c = 5,000$ psi
 $f_y = 65,000$ psi (welded wire fabric)
 $f_y = 60,000$ psi (reinforcement)

SEE SCHEDULE OF QUANTITIES ON SHEET 18 FOR LENGTHS OF PRECAST CONCRETE BOX CULVERTS

Notes:
 All precast concrete box culvert sections shall conform to the requirements of Article 540 of the Standard Specifications.
 Lifting holes shall be filled with concrete plugs and mastic after box sections are in place.
 Approved anchoring devices for $\frac{3}{4}$ " expansion bolts shall be cast into the ends of the precast concrete box culvert sections as detailed on sheet 64.
 Select granular back fill is not required above the Precast Concrete Box Culvert Extensions.

PRECAST CONCRETE BOX CULVERT - EXTENSION DETAILS

Span	Rise	ASTM Designation	Design Fill Height	THICKNESS (INCHES)			A (FT.-IN.)	B (FT.-IN.)	C (INCHES)	D (FT.-IN.)	E (FT.-IN.)	F (FT.-IN.)	G (FT.-IN.)	H (FT.-IN.)	SLOPE X:Y
				Tt (top slab)	Tb (bot. slab)	Tw (wall)									
2'	2'	C1577	< 2'	7"	6"	4"	2'-8"	3'-1"	4"	6'-0"	3'-0"	3'-0"	1'-0"	1'-0"	3:1
3'	2'	C1577	< 2'	7"	6"	4"	3'-8"	3'-1"	4"	6'-0"	3'-0"	3'-0"	1'-0"	1'-0"	3:1
3'	3'	C1577	< 2'	7"	6"	4"	3'-8"	4'-1"	4"	6'-0"	2'-0"	4'-0"	1'-8"	1'-4"	3:1
4'	2'	C1577	< 2'	7 1/2"	6"	5"	4'-10"	3'-1 1/2"	5"	6'-0"	3'-0"	3'-0"	1'-0"	1'-0"	3:1

* The 2'x2' Precast Concrete Box Culvert shall be reinforced as shown in ASTM C 1577 for a 3'x2' Precast Box Culvert with Design Fill equal to less than 2 feet. This design applies to all 2'x2' Culverts on this project, including those with skews > 30 degrees.

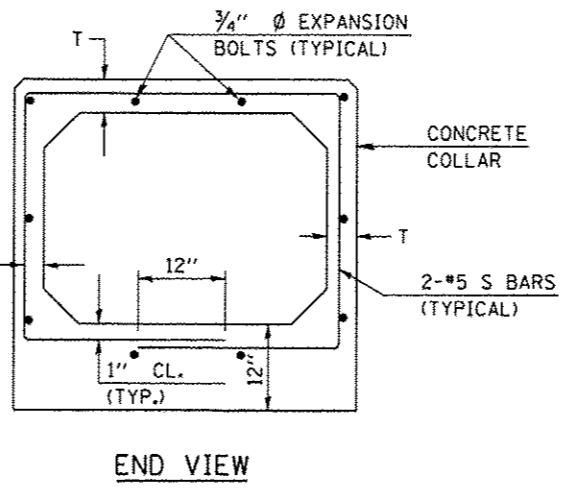
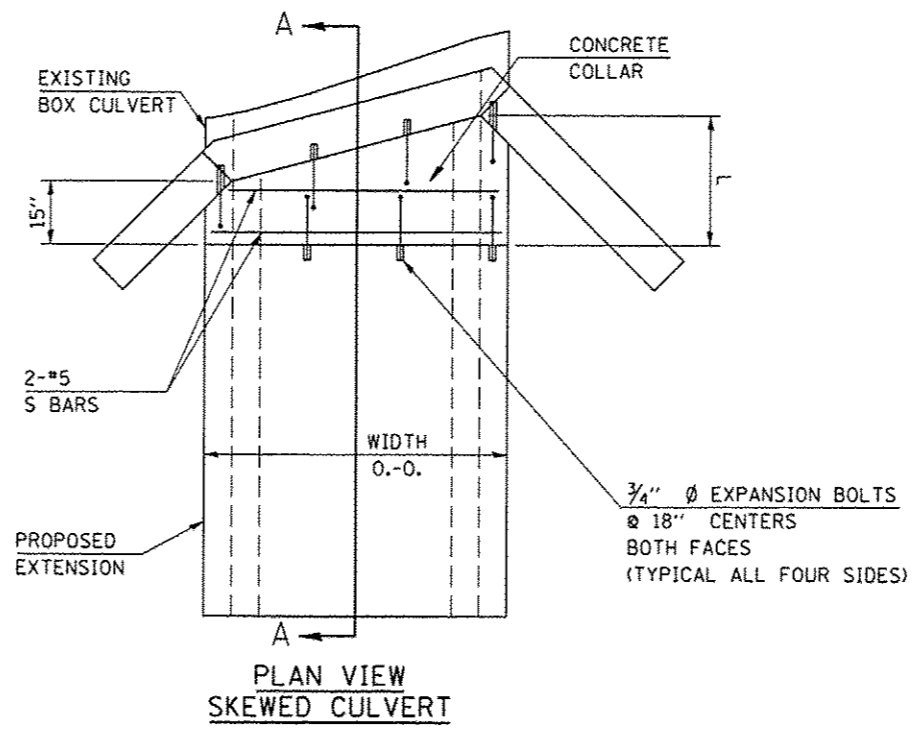
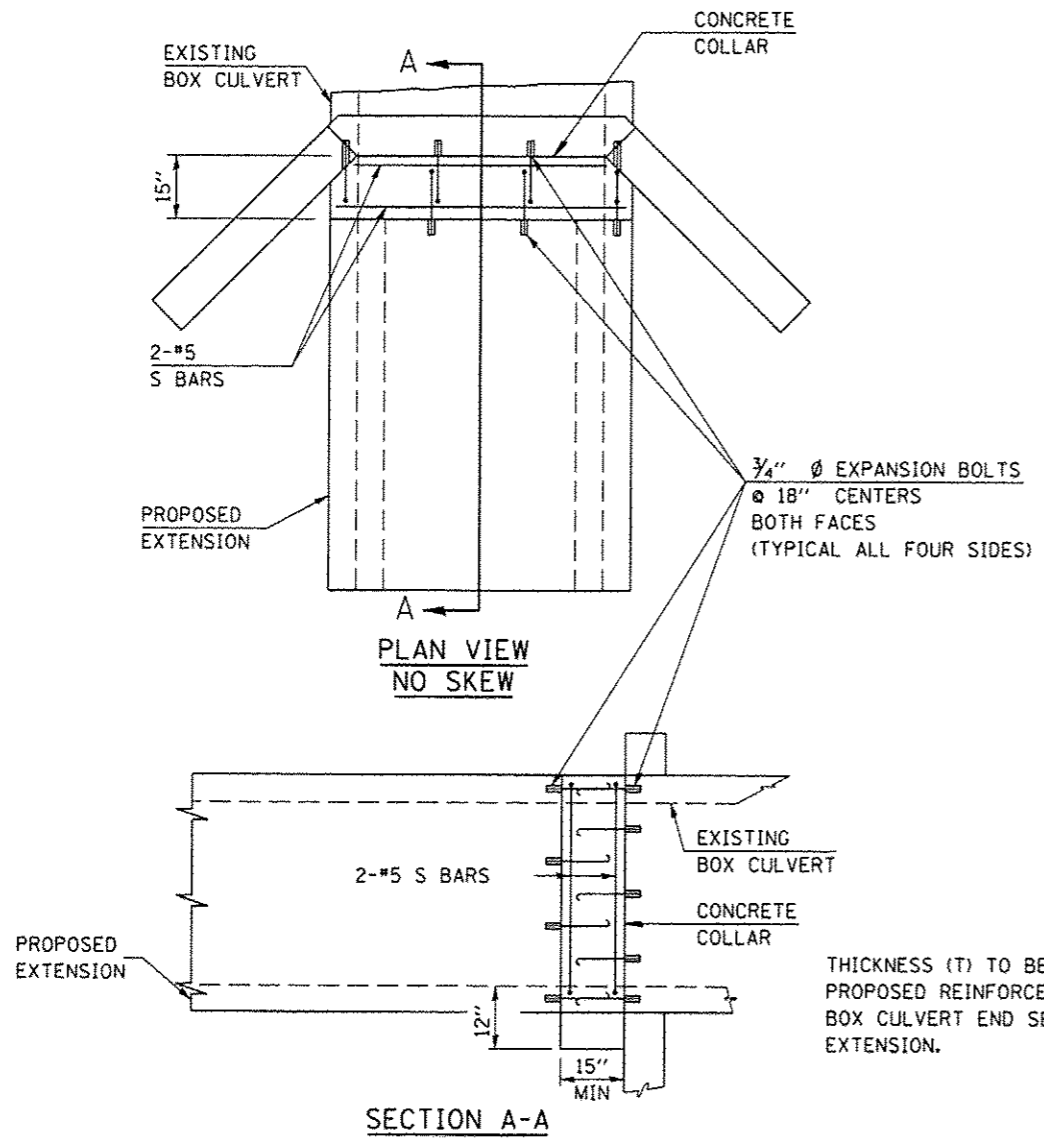

GENERAL NOTES

1. EXPANSION BOLTS, MEETING THE REQUIREMENTS OF ARTICLE 1006.09 OF THE STANDARD SPECIFICATIONS, SHALL EXTEND A MINIMUM OF 9" INTO THE NEW CONCRETE. APPROVED ANCHORING DEVICES SHALL BE CAST INTO THE PRECAST BOX CULVERT SECTIONS.
2. REINFORCEMENT BARS SHALL MEET THE REQUIREMENTS OF ARTICLE 1006.10 OF THE STANDARD SPECIFICATIONS.
3. CLASS SI CONCRETE SHALL BE USED THROUGHOUT.
4. PRECAST BOX CULVERT BARREL SECTIONS PLACED AS PART OF THE EXTENSION WILL BE IN ACCORDANCE WITH APPLICABLE PORTIONS OF SECTION 540 OF THE SPECIFICATIONS
5. CONCRETE COLLARS, REINFORCEMENT BARS, AND EXPANSION BOLTS WILL BE COMPUTED AND INCLUDED IN THE PLAN QUANTITIES FOR THESE PAY ITEMS

TABULATION				
SKEW	SPAN x RISE	CONCRETE COLLAR CU YD	REINFORCEMENT BARS POUNDS	EXPANSION BOLTS EACH
0°	2' x 2'	0.27	30	16
0°	3' x 2'	0.32	30	16
0°	3' x 3'	0.35	30	24
0°	4' x 2'	0.41	30	30
32°	2' x 2'	0.35	30	16
13° 15'	2' x 2'	0.28	30	16
19°	2' x 2'	0.30	30	16

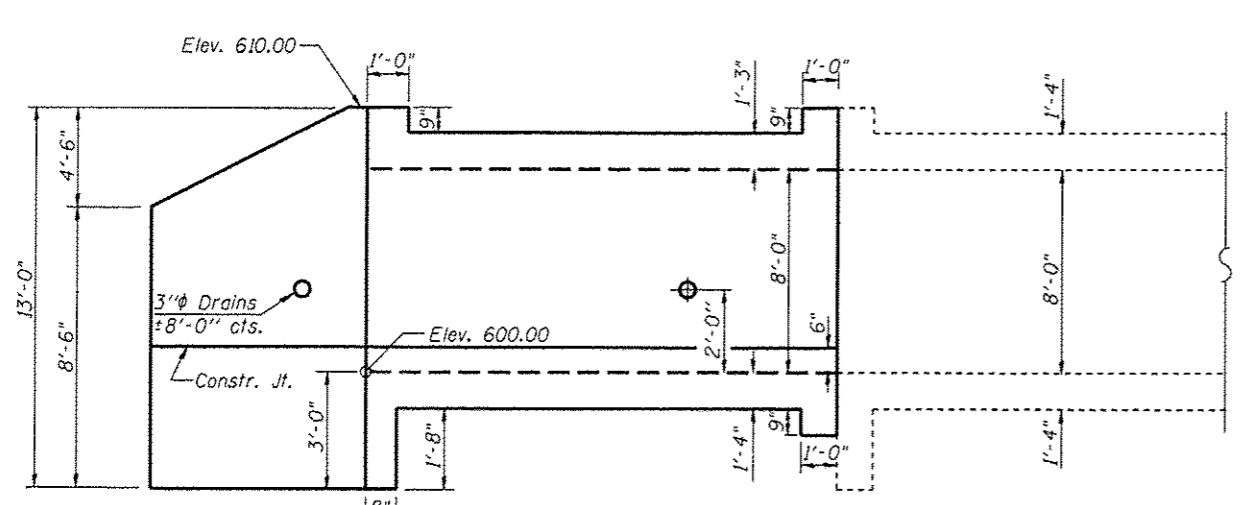

SHOWING DIMENSIONS

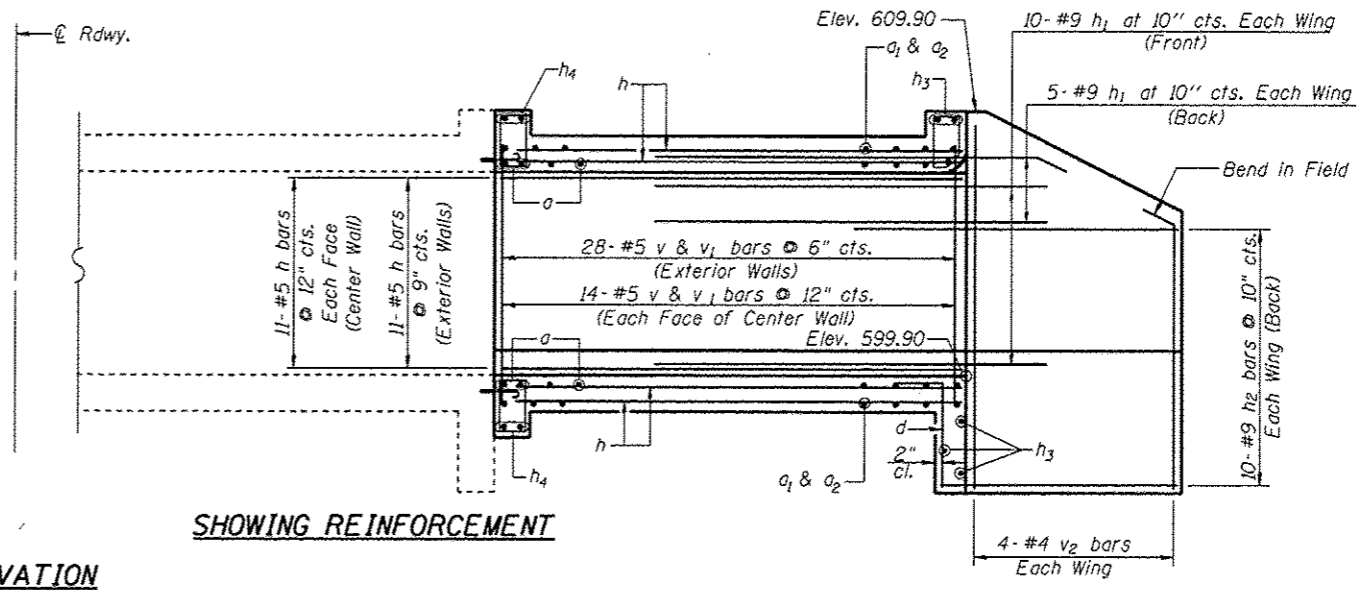

SHOWING REINFORCEMENT

ELEVATION
Looking East

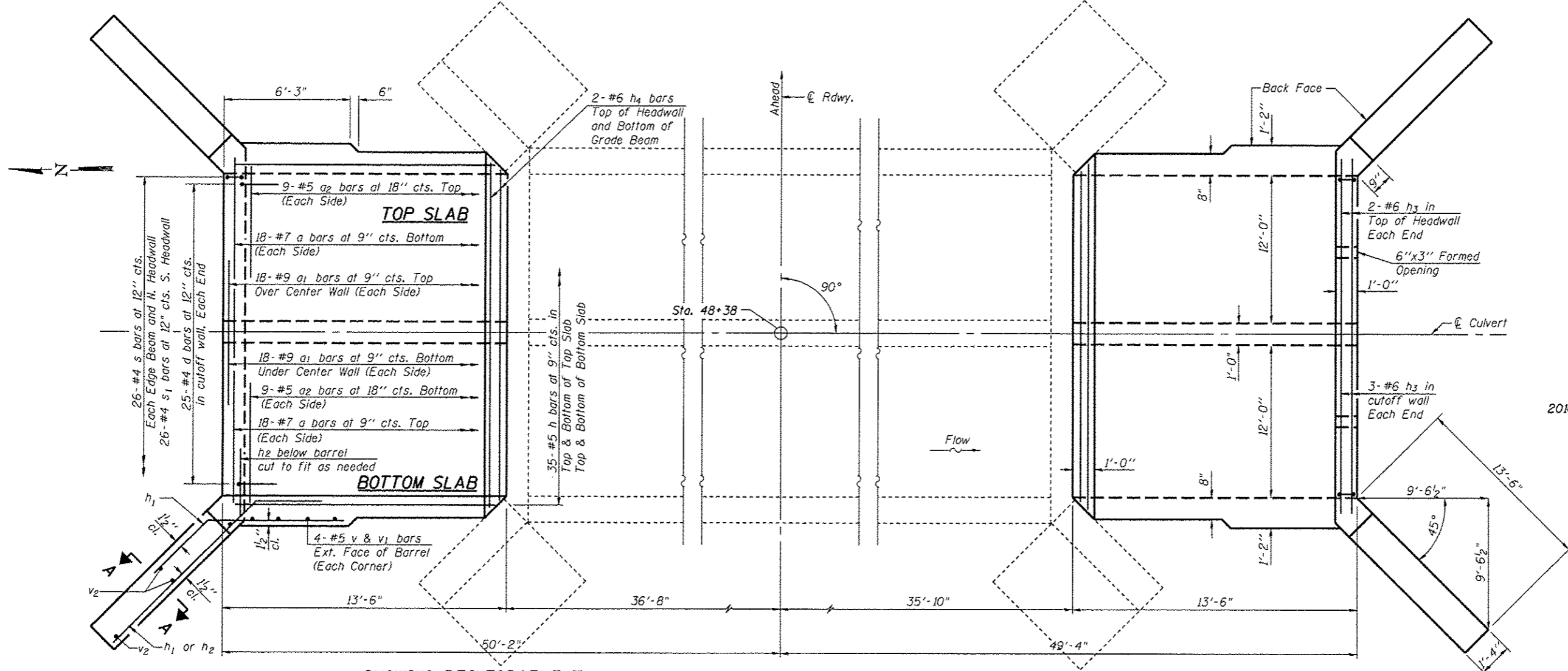

SHOWING REINFORCEMENT

SHOWING OUTLINES

PLAN



Michael D. Cummins 11/25/13
(Expires 11/30/2014)

DESIGN SPECIFICATIONS
2010 AASHTO with 2010 & 2011 Interims
LOADING HL-93
DESIGN STRESSES
 $f_y = 60,000 \text{ psi}$
 $f'_c = 3,500 \text{ psi}$

Notes: The barrel extensions shall be poured monolithically with the wingwalls.



JOB	• 2246	DESIGNED	- ZTB	REVISED	-
FILE	• 2246SNL.dgn	CHECKED	- AAN	REVISED	-
DATE	• 10/10/2011	DRAWN	- TJD	REVISED	-
		CHECKED	- MDC	REVISED	-

STATE OF ILLINOIS
DEPARTMENT OF TRANSPORTATION

CULVERT DETAILS - STATION 48+38
STRUCTURE NO. 059-5004

SHEET NO. 1 OF 2 SHEETS

F.A.S. RTE.	SECTION	COUNTY	TOTAL SHEETS	SHEET NO.
732	01-00079-00-FP	MACOUPIN	141	71
ILLINOIS FED. AID PROJECT			CONTRACT NO. 93574	

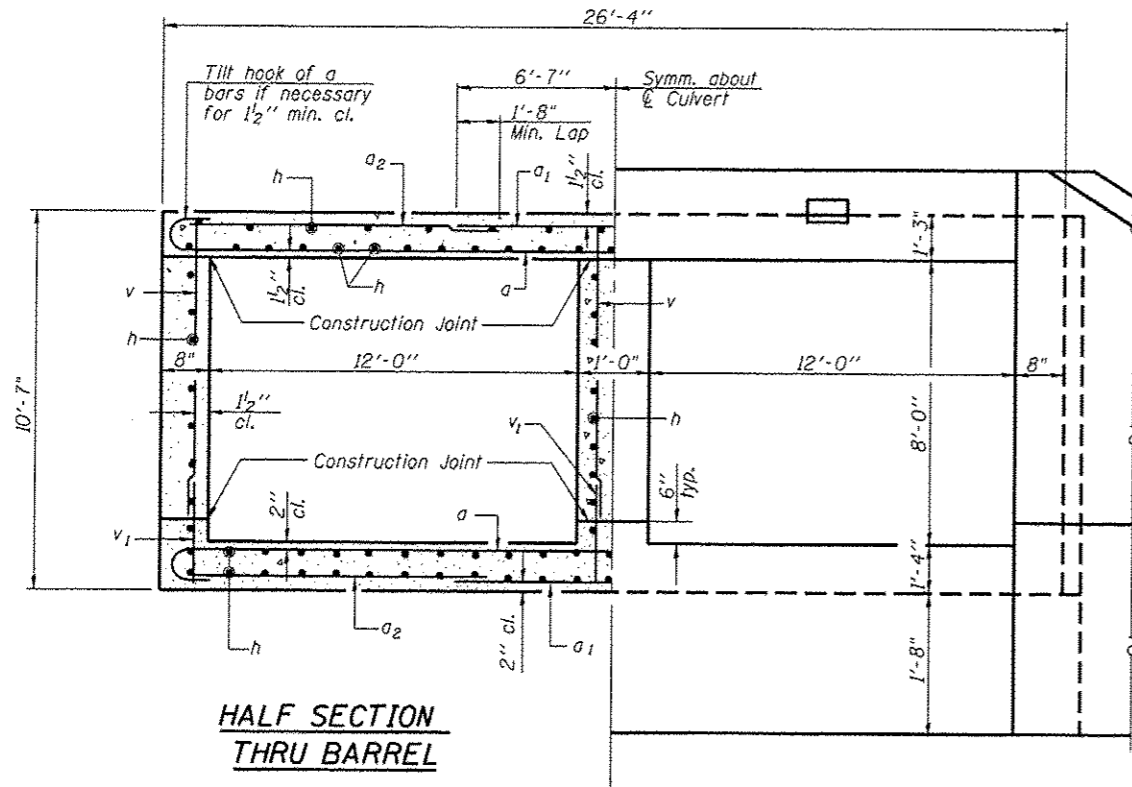

HALF SECTION THRU BARREL

HALF END ELEVATION

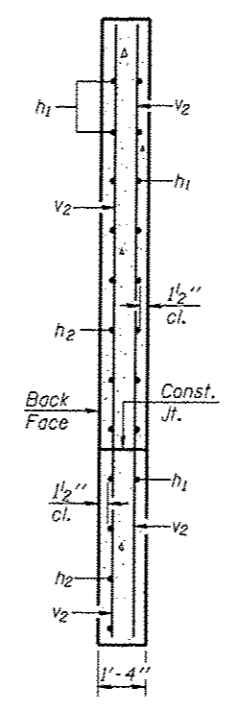

SECTION A-A

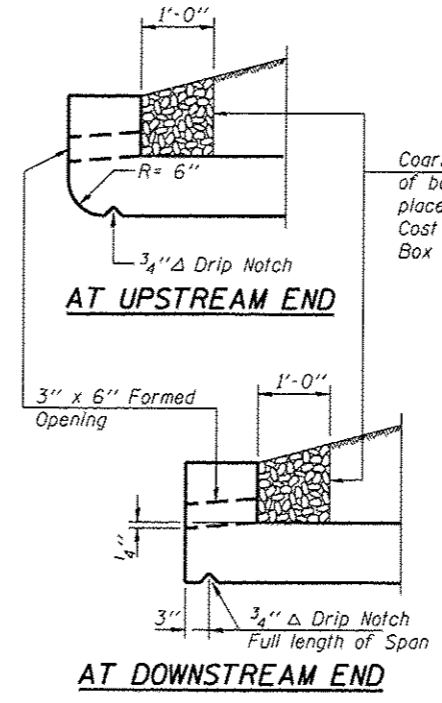

AT UPSTREAM END

AT DOWNSTREAM END

DRAIN DETAIL

Coarse aggregate full length of both headwalls. To be placed by Grading Contractor. Cost included with Concrete Box Culverts.

BILL OF MATERIAL

Bar	No.	Size	Length	Shape
a	72	#7	27'-8"	
a1	72	#9	13'-2"	
a2	72	#5	8'-0"	
d	50	#4	4'-6"	
h	368	#5	13'-2"	
h1	60	#9	9'-9"	
h2	40	#9	16'-6"	
h3	10	#6	26'-3"	
h4	8	#6	25'-0"	
s	130	#4	5'-9"	
s1	26	#4	5'-7"	
v	168	#5	8'-5"	
v1	168	#5	3'-6"	
v2	16	#4	12'-8"	
Concrete Box Culverts			Cu. Yd.	124.4
Reinforcement Bars			Pound	20,770
Expansion Bolts 3/4"x12"			Each	100

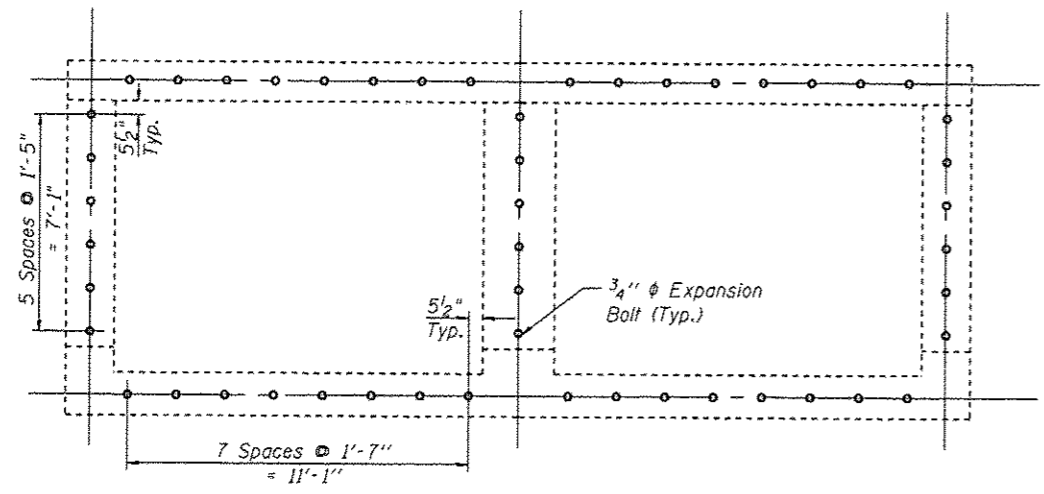

EXISTING END VIEW

(Showing Placement of 3/4" φ Expansion Bolts)

Note: Expansion bolts shall be 3/4" φ hooked bolts. Hooked bolts shall extend a minimum of 9" into new concrete.

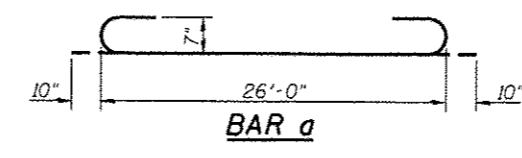

BAR a

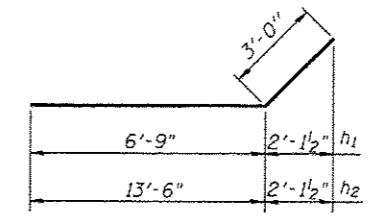

BARS h1 & h2

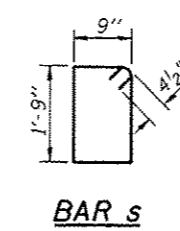

BAR s

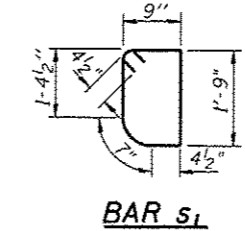

BAR s1

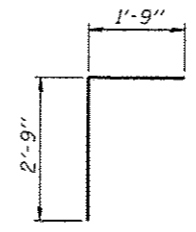

BAR d

WATERWAY INFORMATION - LOCATION 1

Drainage Area	2.9 Sq. Mi.
Existing Opening (20 yr.)	173 Sq. Ft.
Proposed Opening (20 yr.)	173 Sq. Ft.
Existing Opening (100 yr.)	187 Sq. Ft.
Proposed Opening (100 yr.)	187 Sq. Ft.
20 year Design Discharge	1,390 c.f.s.
20 year Design Headwater Elev.	608.5 Ft.
100 year Discharge	2,075 c.f.s.
100 year Headwater Elev.	610.6 Ft.

DESIGN SCOUR ELEVATION TABLE

Design Scour Elevation (ft.)	Upstream	Downstream
	597.0	596.9

GENERAL NOTES

- The barrel extension shall be poured monolithically with the wingwalls.
- Exposed edges shall be beveled 3/4".
- Reinforcement Bars shall conform to the requirements of ASTM A 706 Grade 60.
- All construction joints shall be bonded.
- Plan dimensions and details relative to the existing structure are subject to nominal variations. It shall be the Contractor's responsibility to verify such dimensions and details in the field and make necessary approved adjustments prior to construction or ordering of materials. Such variations shall not be cause for additional compensation for a change in the scope of the work, however, the Contractor will be paid for the quantity actually furnished at the unit price for the work.
- The Precast Alternate is not allowed.



JOB # 2246
 FILE # 2246SNI.dgn
 DATE # 10/10/2011

DESIGNED - ZTB
 CHECKED - AAN
 DRAWN - TJD
 CHECKED - MDC

REVISED -
 REVISED -
 REVISED -
 REVISED -

STATE OF ILLINOIS
 DEPARTMENT OF TRANSPORTATION

CULVERT DETAILS - STATION 48+38
 STRUCTURE NO. 059-5004

SHEET NO. 2 OF 2 SHEETS

F.A.S. RTE.	SECTION	COUNTY	TOTAL SHEETS	SHEET NO.
732	01-00079-00-FP	MACOUPIN	141	72

CONTRACT NO. 93574
 ILLINOIS FED. AID PROJECT

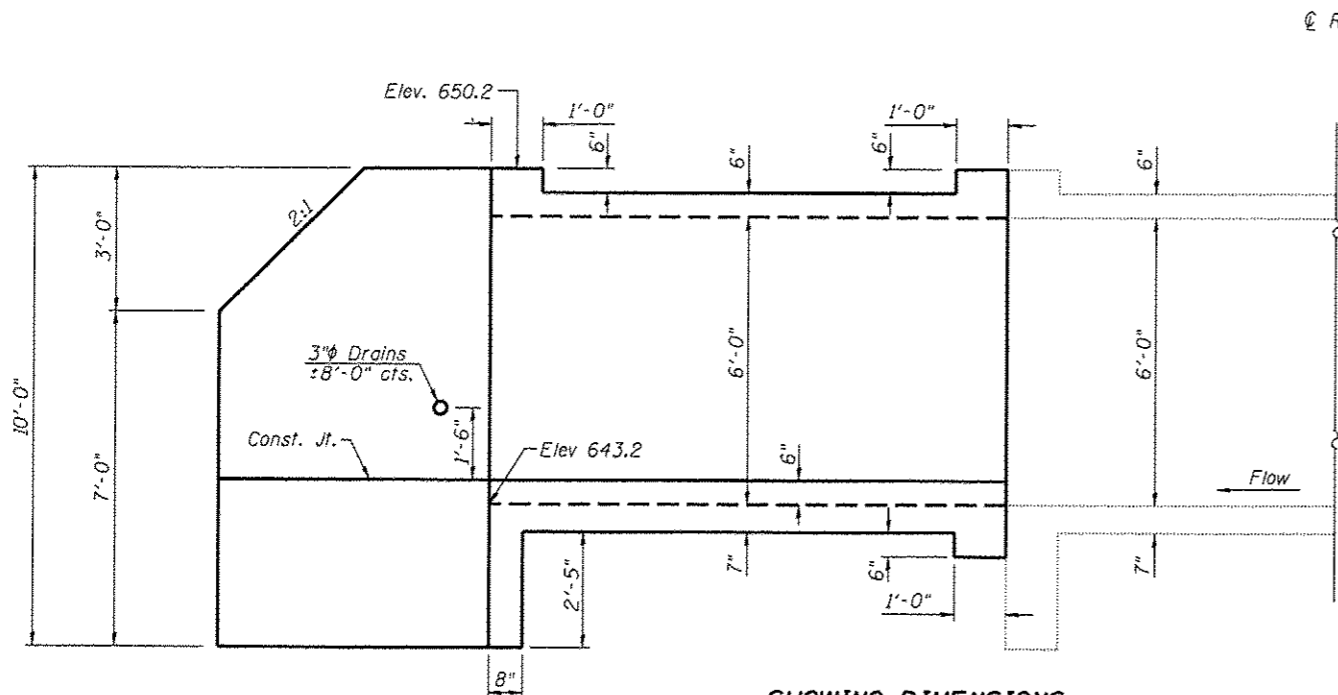

SHOWING DIMENSIONS

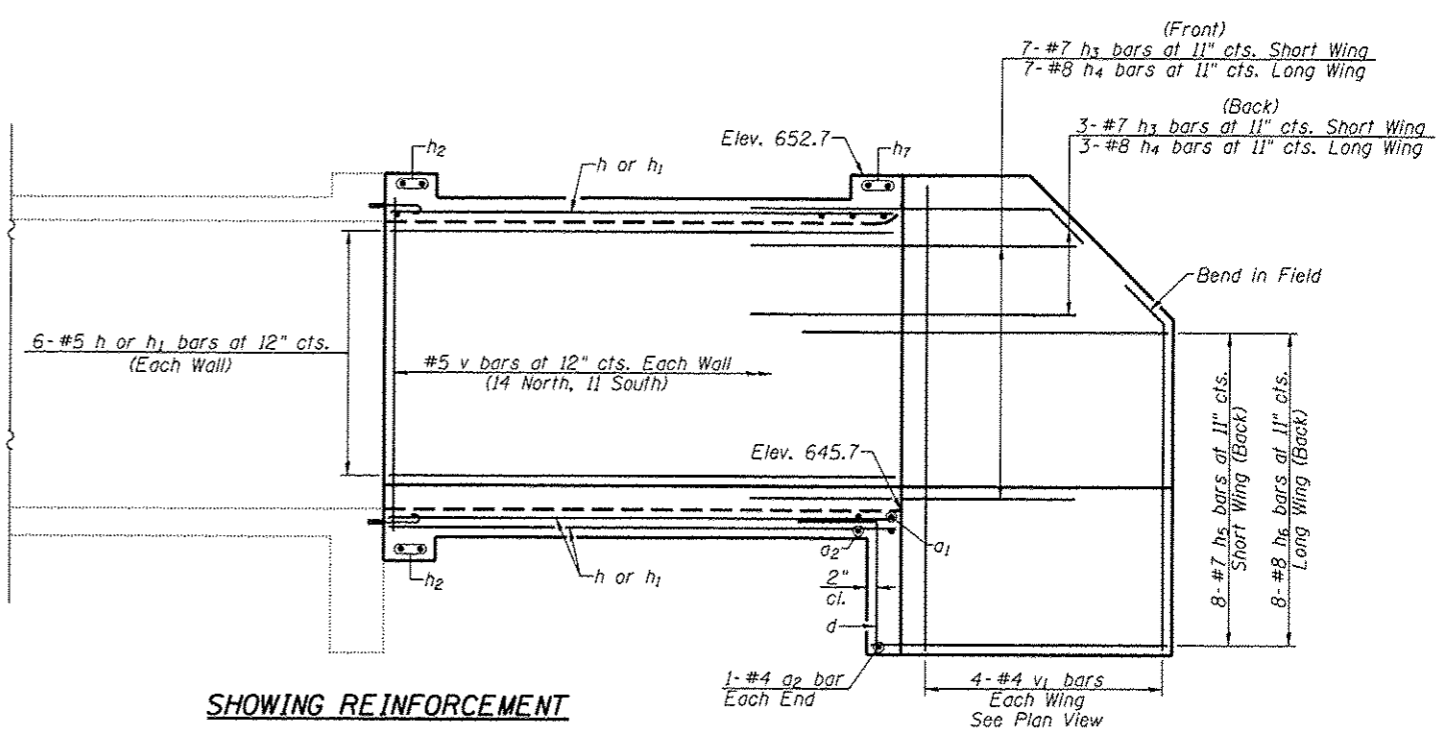

SHOWING REINFORCEMENT

ELEVATION
Looking East

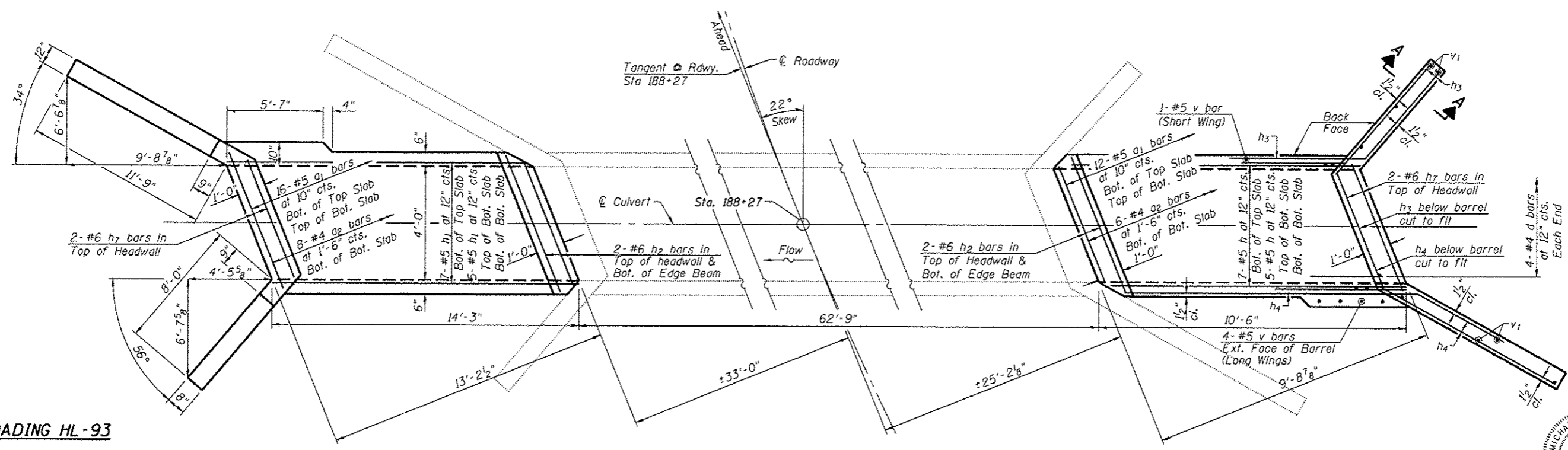

PLAN

LOADING HL-93

DESIGN SPECIFICATIONS

2010 AASHTO with 2010 & 2011 Interims

DESIGN STRESSES

$f_y = 60,000 \text{ psi}$
 $f_6 = 3,500 \text{ psi}$

SHOWING REINFORCEMENT

WATERWAY INFORMATION - LOCATION 2

Drainage Area 10 Acres
30 year Design Discharge 35 c.f.s.
30 year Design Headwater Elev. 648.3 Ft.

SHOWING OUTLINES

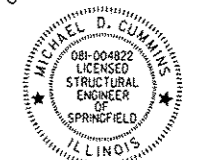

Michael D. Cummins 11/25/13
(Expires 11/30/2014)



JOB	• 2246	DESIGNED	- ZTB	REVISED	-
FILE	• 2246SN2.dgn	CHECKED	- AAN	REVISED	-
DATE	• 10/10/2011	DRAWN	- TJD	REVISED	-
		CHECKED	- MOC	REVISED	-

STATE OF ILLINOIS
DEPARTMENT OF TRANSPORTATION

CULVERT DETAILS - STATION 188+27

SHEET NO. 1 OF 2 SHEETS

F.A.S. RTE.	SECTION	COUNTY	TOTAL SHEETS	SHEET NO.
732	01-00079-00-FP	MACOUPIN	141	73
				CONTRACT NO. 93574
ILLINOIS FED. AID PROJECT				

GENERAL NOTES

The barrel extension shall be poured monolithically with the wingwalls.

Exposed edges shall be beveled 3/4".

Reinforcement Bars shall conform to the requirements of ASTM A 706 Grade 60.

All construction joints shall be bonded.

Plan dimensions and details relative to the existing structure are subject to nominal variations. It shall be the Contractor's responsibility to verify such dimensions and details in the field and make necessary approved adjustments prior to construction or ordering of materials. Such variations shall not be cause for additional compensation for a change in the scope of the work, however, the Contractor will be paid for the quantity actually furnished at the unit price for the work.

The Precast Alternate is not allowed.

Tilt hook of a bars
If necessary to maintain
1/2" min. cl.

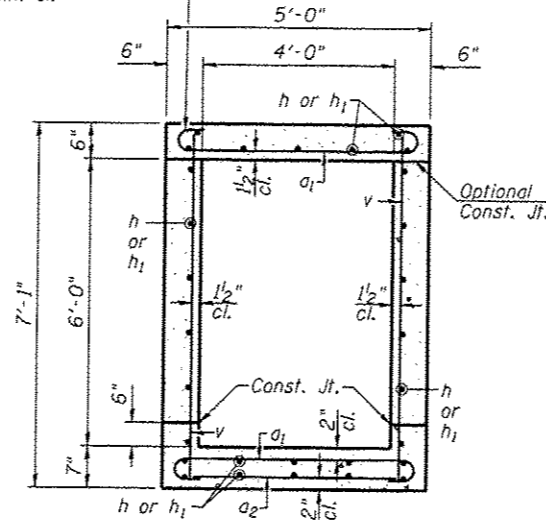

SECTION THRU BARREL
(Dim.'s are @ Right L's)

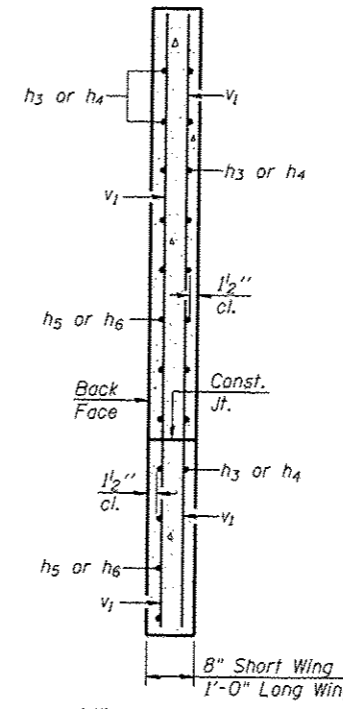

SECTION A-A

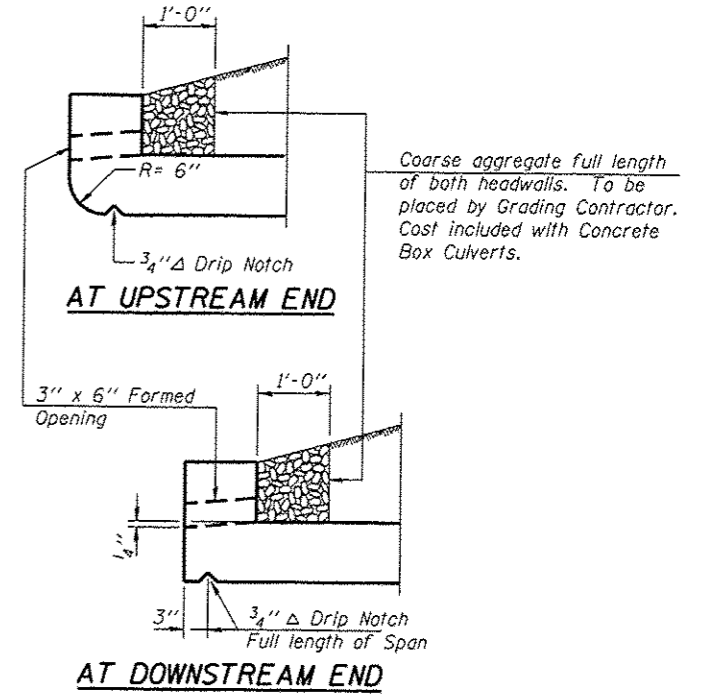

DRAIN DETAIL

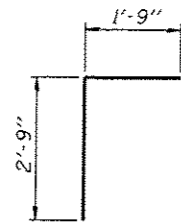
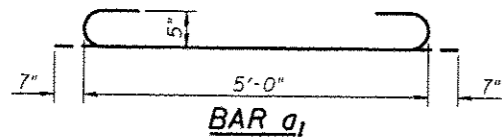

BAR d

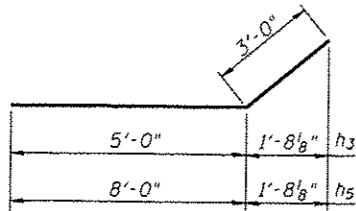

BARS h3 & h5

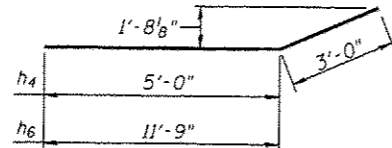

BARS h4 & h6

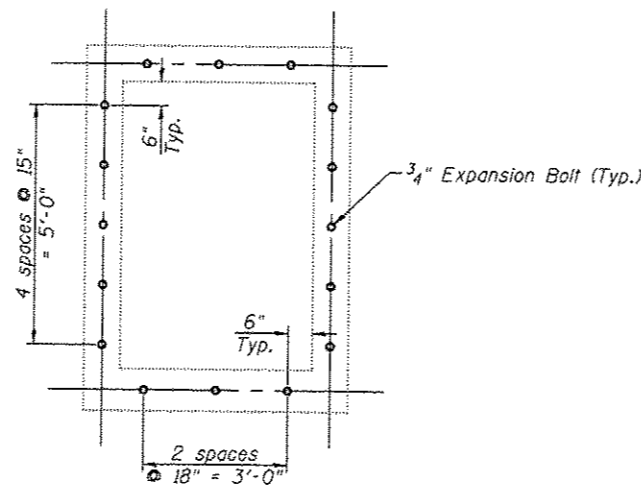

SECTION THRU BARREL
(Location of Expansion Bolts)
(Dim.'s are @ Right L's)

Note:
Expansion bolts shall be 3/4" φ hooked bolts. Hooked bolts shall extend a minimum of 9" into new concrete.

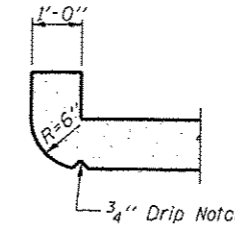

SECTION THRU HEADWALL
(Up Stream End Only)

BILL OF MATERIAL

Bar	No.	Size	Length	Shape
a1	56	#5	6'-2"	C
a2	16	#5	5'-0"	—
d	8	#4	4'-6"	L
h	29	#5	10'-2"	—
h1	29	#5	13'-11"	—
h2	8	#6	4'-2"	—
h3	20	#7	8'-0"	—
h4	20	#8	8'-0"	—
h5	16	#7	11'-0"	—
h6	16	#8	14'-9"	—
h7	4	#6	4'-7"	—
v	60	#5	6'-9"	—
v1	16	#4	9'-8"	—
Concrete Box Culverts			Cu. Yd.	23.3
Reinforcement Bars			Pound	3550
Expansion Bolts 3/4"x12"			Each	32

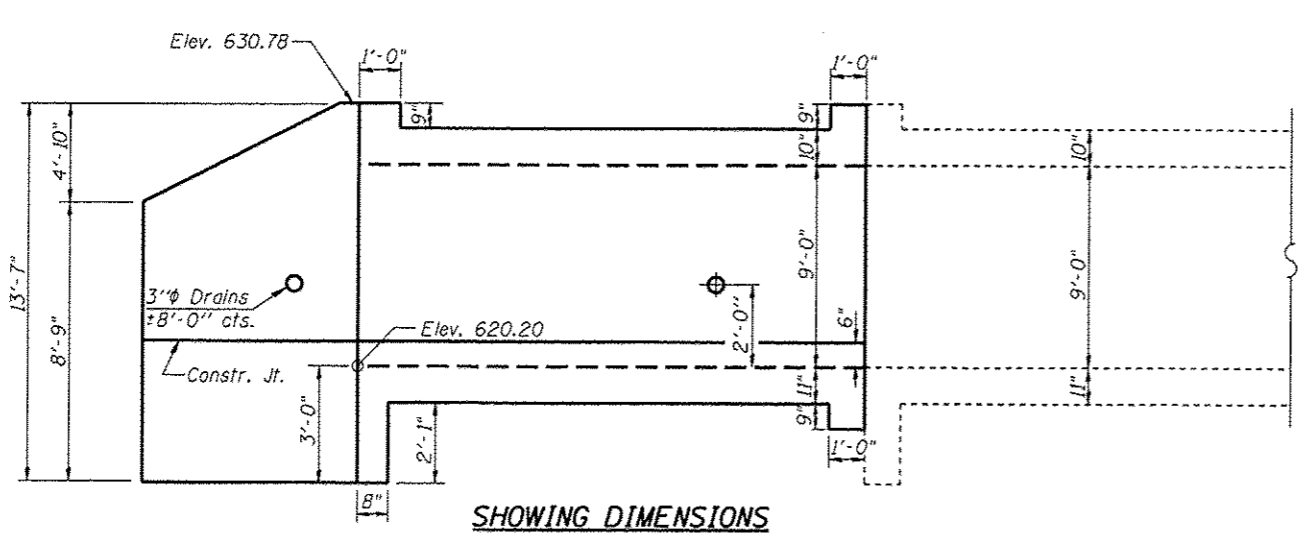

SHOWING DIMENSIONS

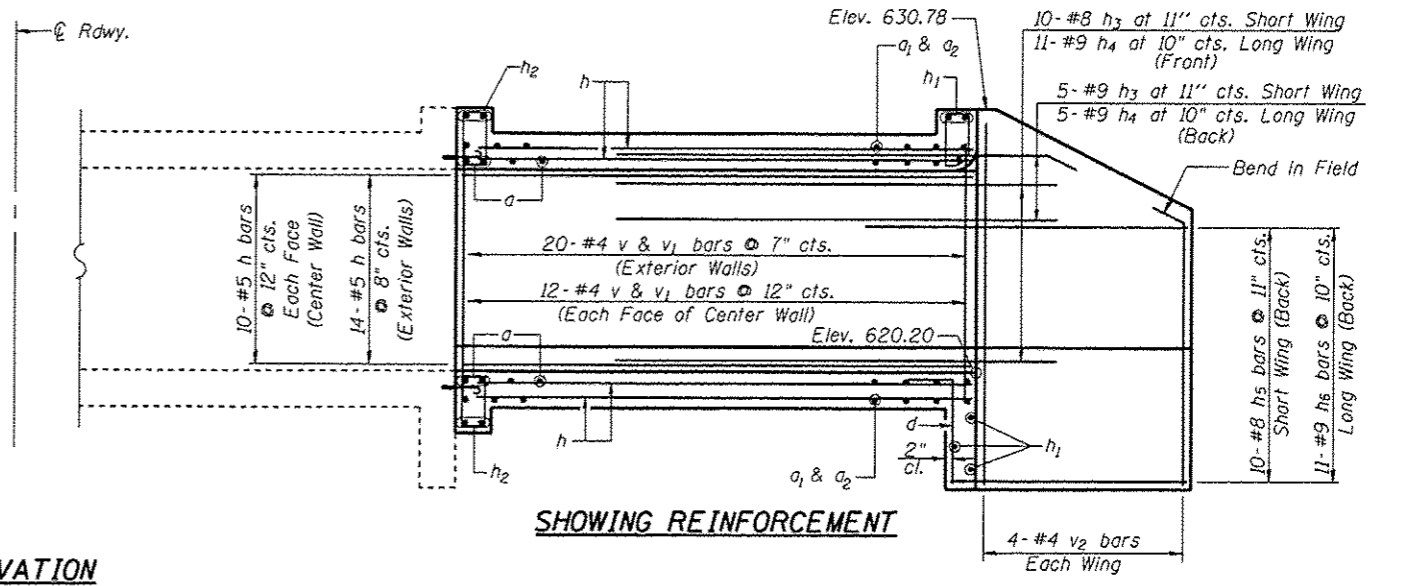

ELEVATION
Looking East

SHOWING REINFORCEMENT

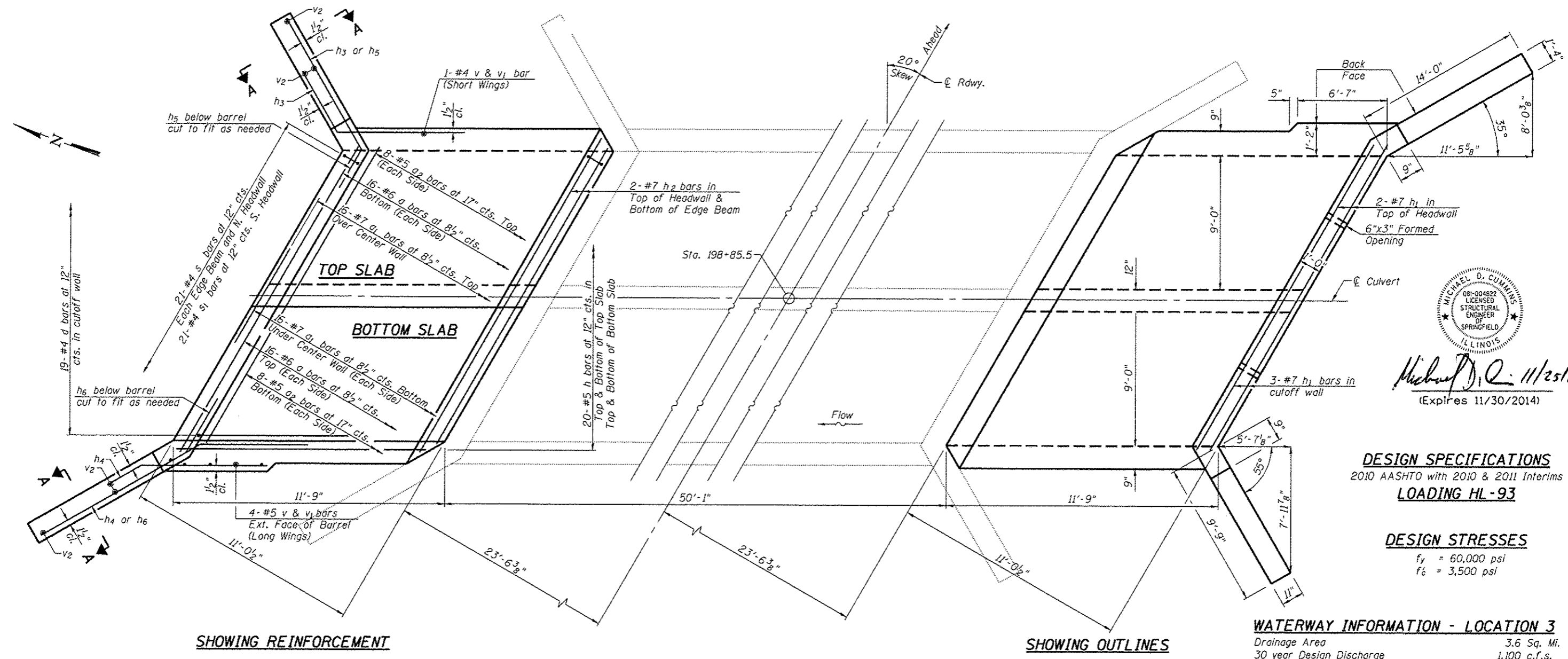

SHOWING REINFORCEMENT

PLAN

SHOWING OUTLINES

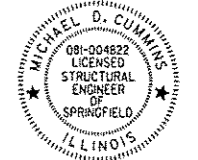

Michael D. Cummins
11/25/13
(Expires 11/30/2014)

DESIGN SPECIFICATIONS
2010 AASHTO with 2010 & 2011 Interims
LOADING HL-93

DESIGN STRESSES
fy = 60,000 psi
fc = 3,500 psi

WATERWAY INFORMATION - LOCATION 3
Drainage Area 3.6 Sq. Mi.
30 year Design Discharge 1,100 c.f.s.
30 year Design Headwater Elev. 628.6 Ft.



JOB	• 2246	DESIGNED	- ZTB	REVISED	-
FILE	• 2246SN3.dgn	CHECKED	- AAN	REVISED	-
DATE	• 10/10/2011	DRAWN	- TJD	REVISED	-
		CHECKED	- MDC	REVISED	-

STATE OF ILLINOIS
DEPARTMENT OF TRANSPORTATION

CULVERT DETAILS - STATION 198+85.5
STRUCTURE NO. 059-5009

F.A.S. RTE.	SECTION	COUNTY	TOTAL SHEETS	SHEET NO.
T32	01-00079-00-PP	MACOUPIN	141	75
				CONTRACT NO. 93574

SHEET NO. 1 OF 2 SHEETS

ILLINOIS FED. AID PROJECT

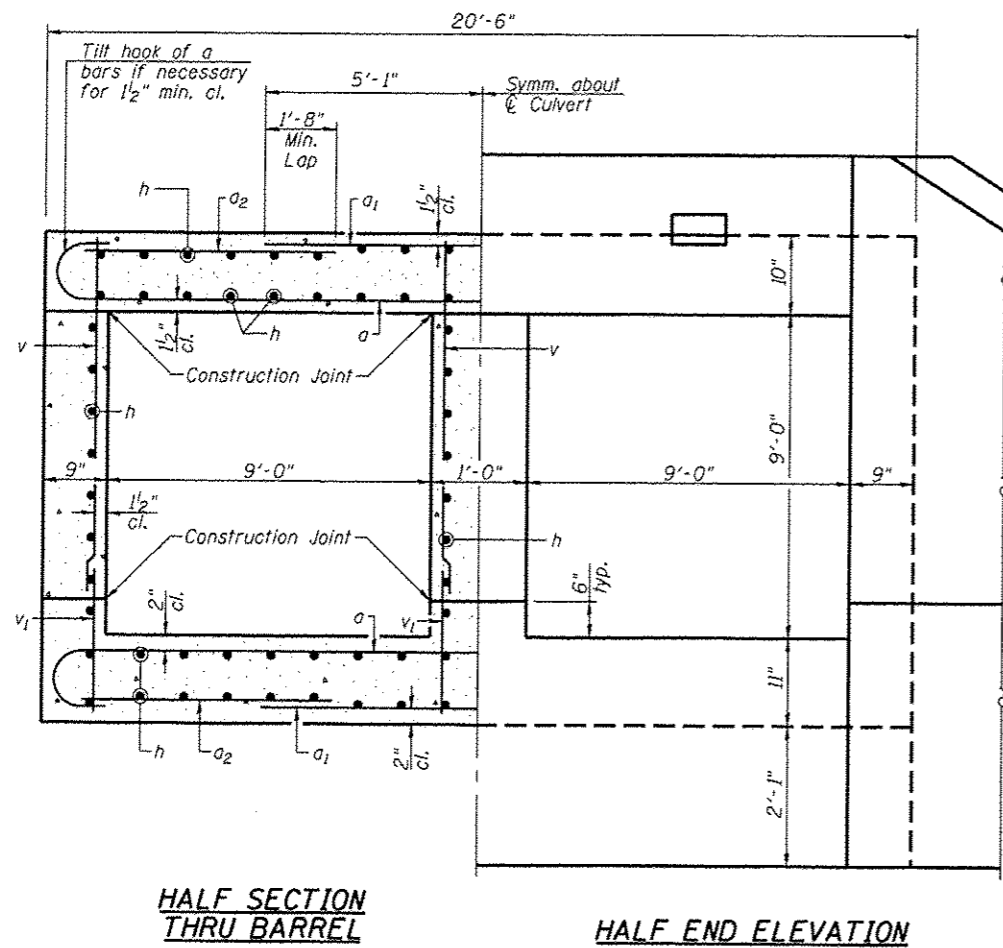

HALF SECTION THRU BARREL

HALF END ELEVATION

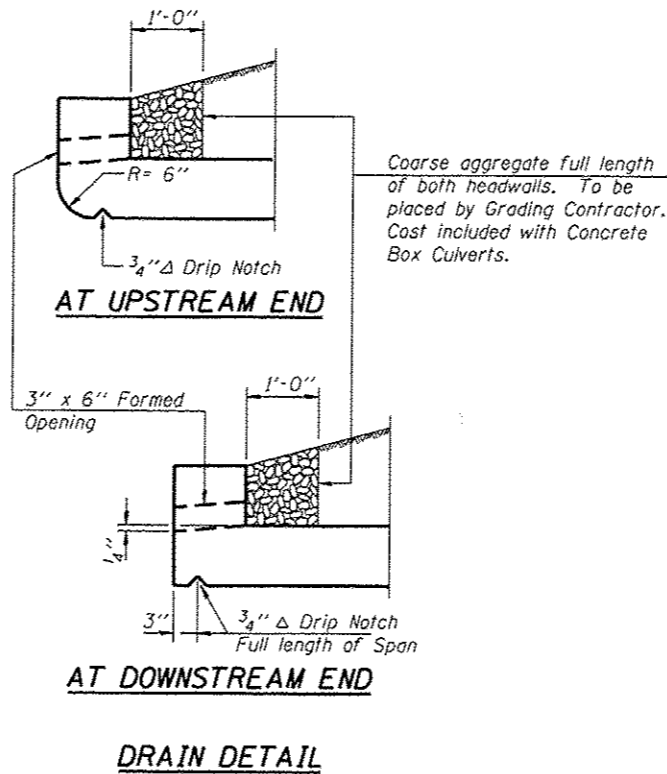

AT UPSTREAM END

AT DOWNSTREAM END

DRAIN DETAIL

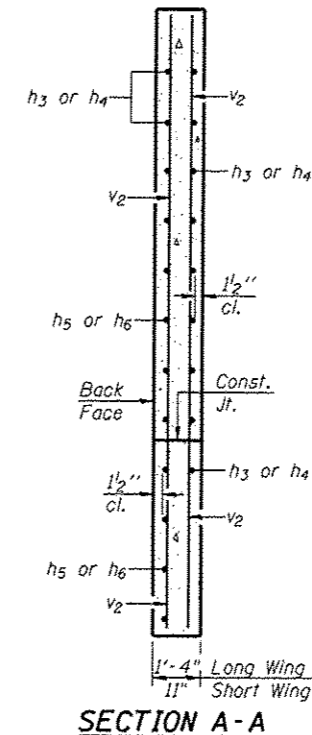

SECTION A-A

BILL OF MATERIAL

Bar	No.	Size	Length	Shape
a	64	#6	22'-10"	U
a ₁	64	#7	10'-10"	—
a ₂	64	#5	7'-2"	—
d	38	#4	4'-6"	L
h	256	#5	11'-5"	—
h ₁	10	#7	21'-0"	—
h ₂	8	#7	20'-3"	—
h ₃	30	#8	8'-0"	—
h ₄	32	#9	8'-0"	—
h ₅	20	#8	12'-9"	—
h ₆	22	#9	17'-0"	—
s	105	#4	4'-11"	□
s ₁	21	#4	4'-9"	□
v	144	#4	9'-0"	—
v ₁	144	#4	2'-9"	—
v ₂	16	#4	13'-3"	—
Concrete Box Culverts			Cu. Yd.	81.6
Reinforcement Bars			Pound	13170
Expansion Bolts 3/4" x 12"			Each	84

DESIGN SCOUR ELEVATION TABLE

Design Scour Elevation (ft.)	Upstream	Downstream
	617.2	617.2

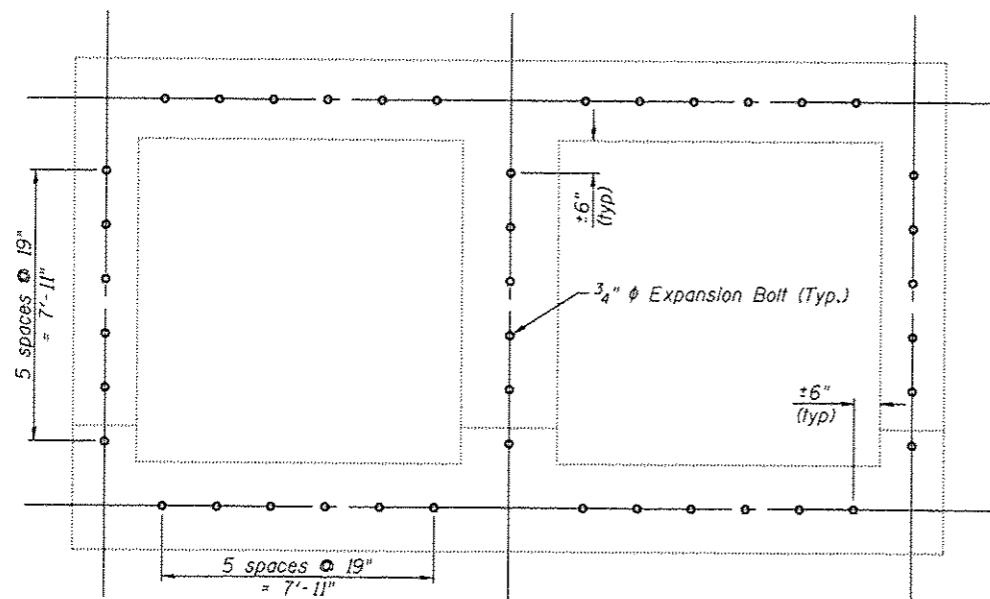

EXISTING END VIEW

(Showing Placement of 3/4" Expansion Bolts)

Note:
Expansion bolts shall be 3/4" φ hooked bolts. Hooked bolts shall extend a minimum of 9" into new concrete.

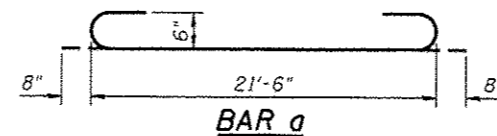

BAR a

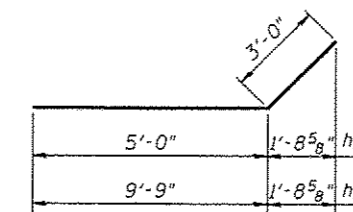

BARS h₃ & h₅

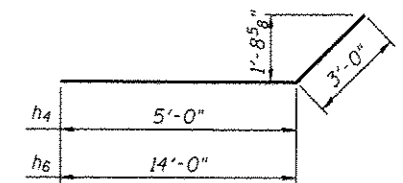

BARS h₄ & h₆

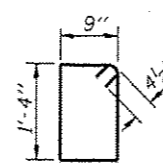

BAR s

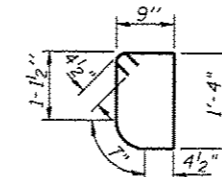

BAR s₁

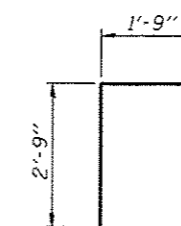

BAR d

GENERAL NOTES

The barrel extension shall be poured monolithically with the wingwalls.

Exposed edges shall be beveled 3/4".

Reinforcement Bars shall conform to the requirements of ASTM A 706 Grade 60.

All construction joints shall be bonded.

Plan dimensions and details relative to the existing structure are subject to nominal variations. It shall be the Contractor's responsibility to verify such dimensions and details in the field and make necessary approved adjustments prior to construction or ordering of materials. Such variations shall not be cause for additional compensation for a change in the scope of the work, however, the Contractor will be paid for the quantity actually furnished at the unit price for the work.

The Precast Alternate is not allowed.

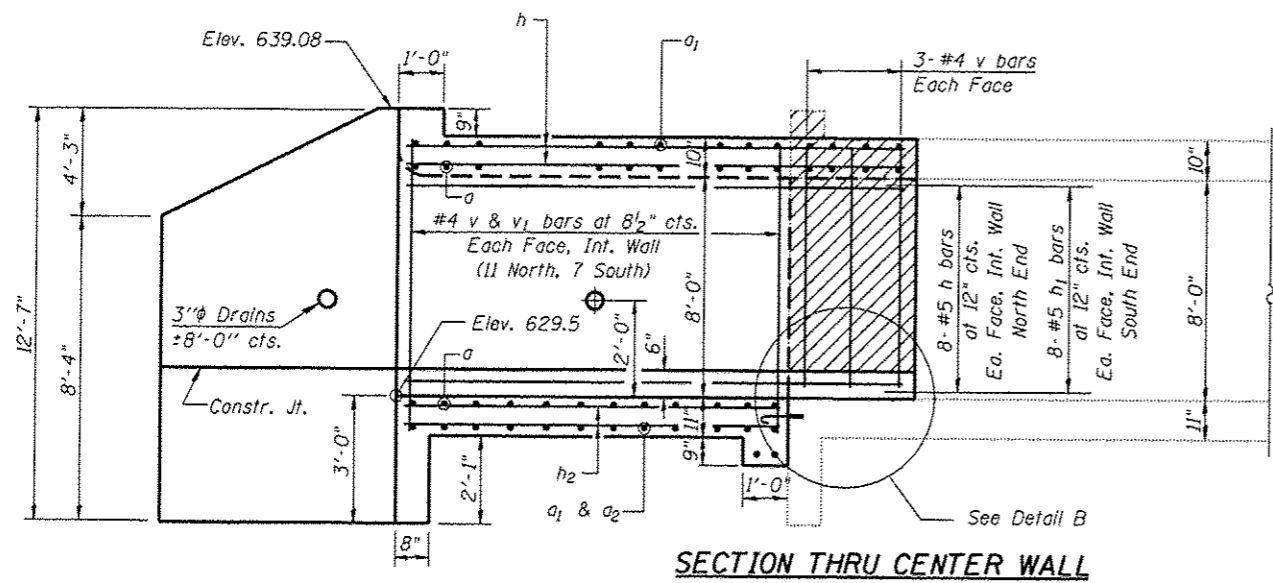

SECTION THRU CENTER WALL

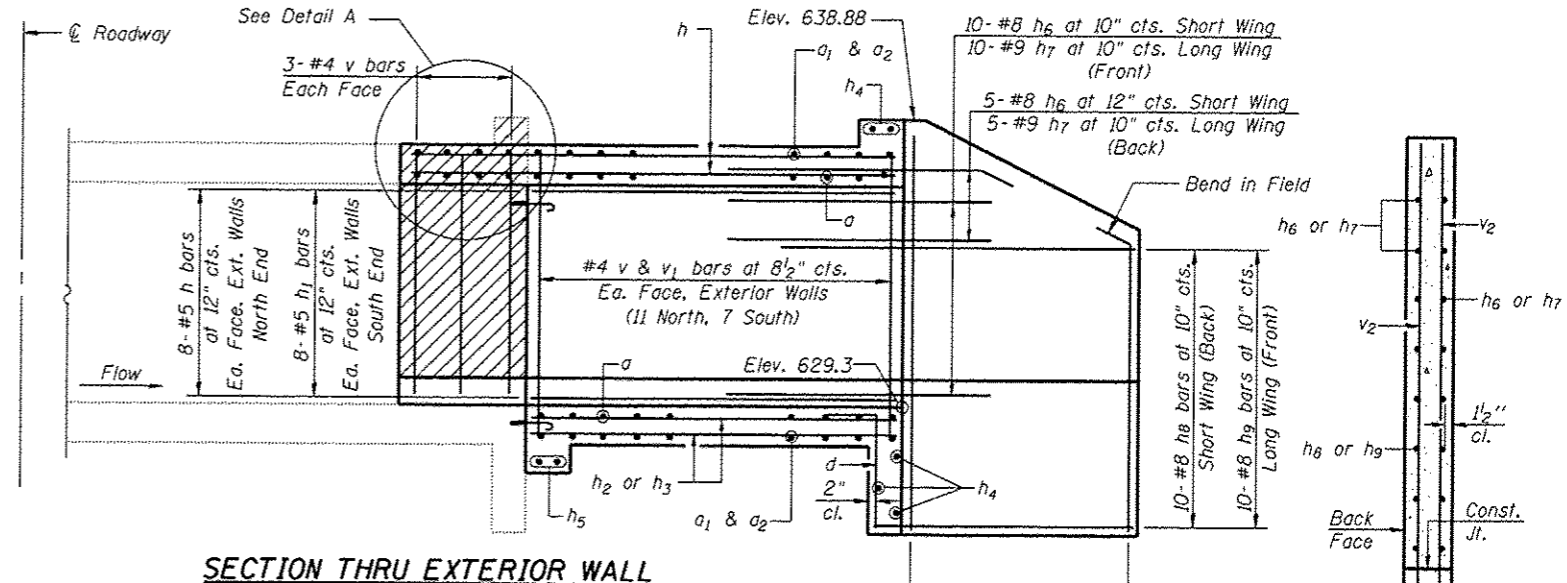

SECTION THRU EXTERIOR WALL

ELEVATION
Looking East

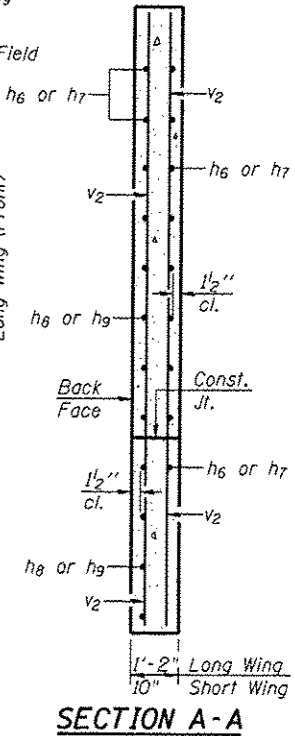

SECTION A-A

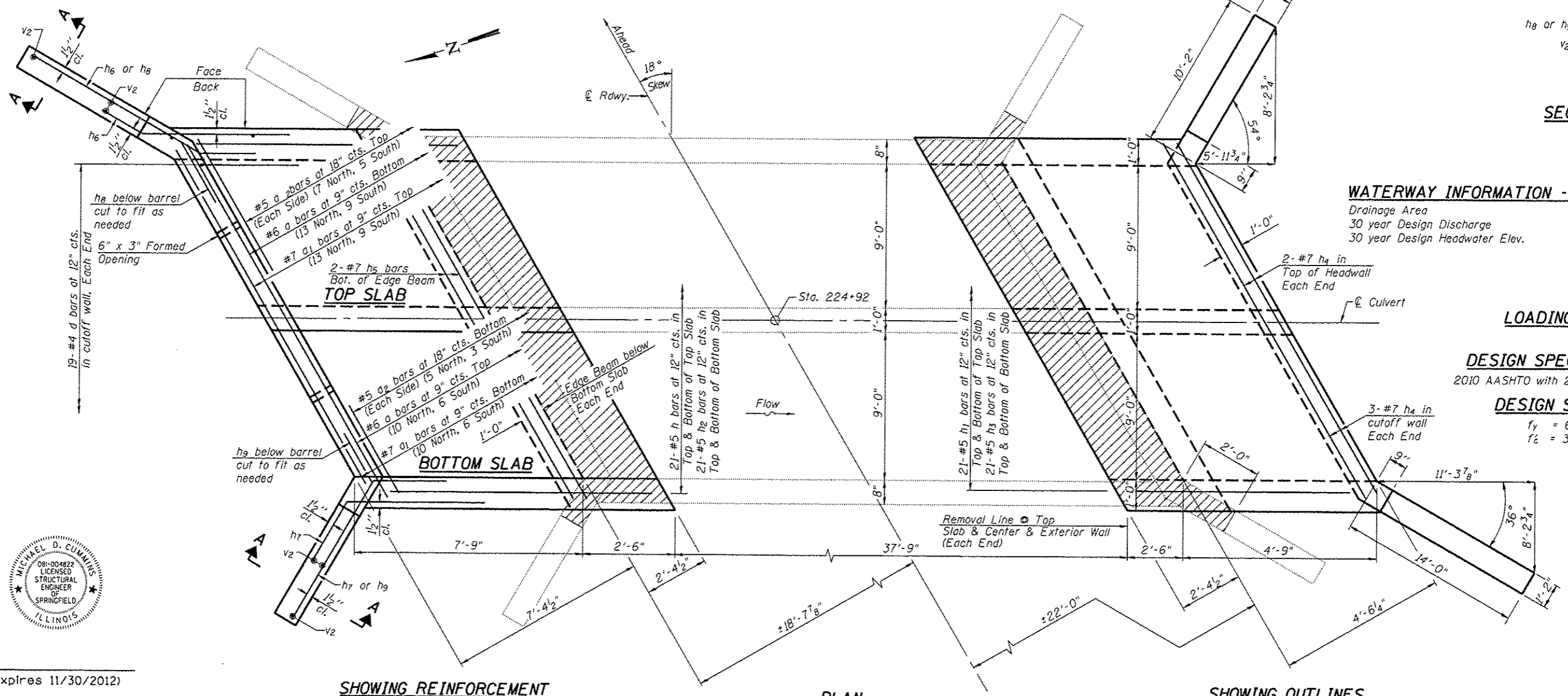

SHOWING REINFORCEMENT

PLAN

SHOWING OUTLINES

WATERWAY INFORMATION - LOCATION 4
 Drainage Area: 2.5 Sq. Mi.
 30 year Design Discharge: 900 c.f.s.
 30 year Design Headwater Elev.: 637.0 Ft.

LOADING HL-93

DESIGN SPECIFICATIONS
 2010 AASHTO with 2010 & 2011 Interims

DESIGN STRESSES
 $f_y = 60,000$ psi
 $f'_c = 3,500$ psi

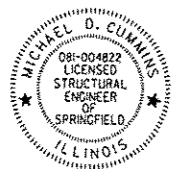

(Expires 11/30/2012)

CEC Cummins Engineering Corporation
 Civil and Structural Engineering

JOB	* 2246	DESIGNED	- ZTB	REVISED	-
FILE	* 2246SN4.dgn	CHECKED	- AAN	REVISED	-
DATE	* 11/4/2010	DRAWN	- TJD	REVISED	-
		CHECKED	- MDC	REVISED	-

STATE OF ILLINOIS
 DEPARTMENT OF TRANSPORTATION

CULVERT DETAILS - STATION 224+92
 STRUCTURE NO.

SHEET NO. 1 OF 2 SHEETS

F.A.S. RTE.	SECTION	COUNTY	TOTAL SHEETS	SHEET NO.
732	01-00079-00-FP	MACOUPIN	141	77
CONTRACT NO. 93574			ILLINOIS FED. AID PROJECT	

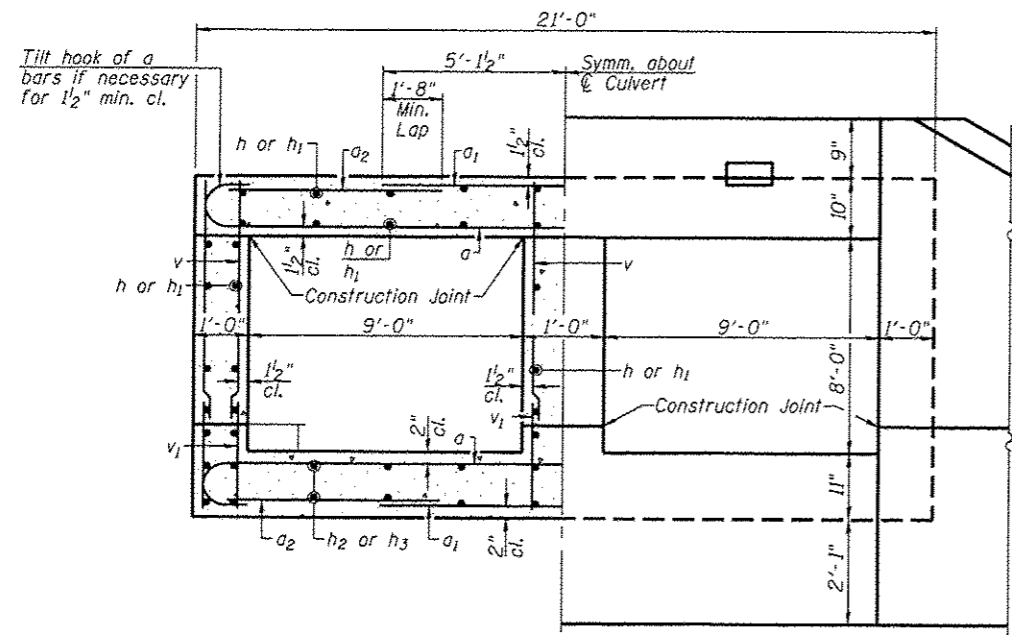

HALF SECTION THRU BARREL **HALF END ELEVATION**

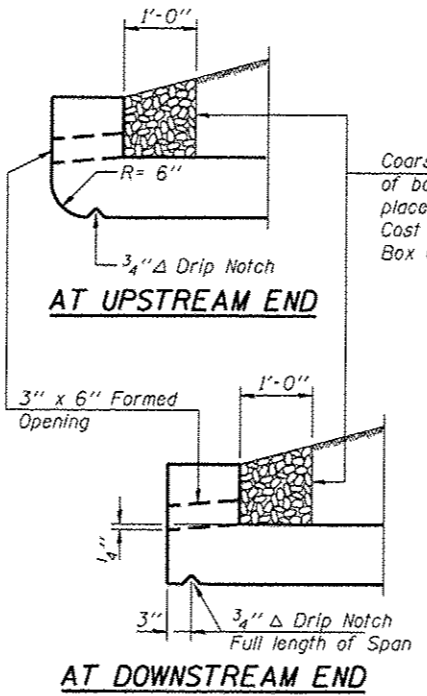

DRAIN DETAIL

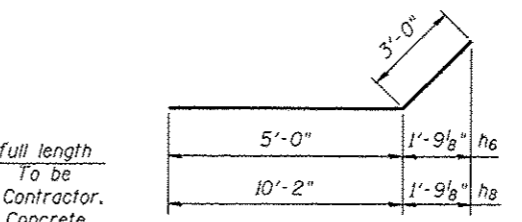

BARS h6 & h8

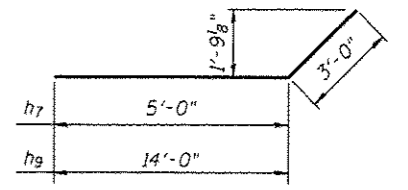

BARS h7 & h9

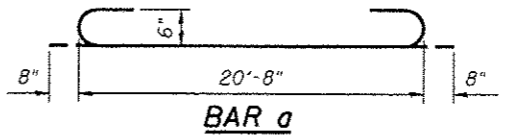

BAR a

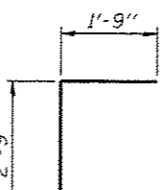

BAR d

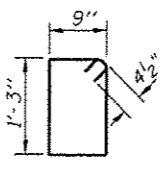

BAR s

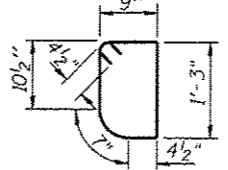

BAR s1

GENERAL NOTES

Hatched areas indicate limits of Concrete Removal.
 The barrel extension shall be poured monolithically with the wingwalls.
 Exposed edges shall be beveled 3/4".
 Reinforcement Bars shall conform to the requirements of ASTM A 706 Grade 60.
 Existing reinforcement bars extending into the removal area shall be cleaned, straightened and incorporated into the new construction. All reinforcement bars that are damaged during concrete removal shall be replaced with an approved bar splicer or anchorage system. Cost included in the cost of Concrete Removal.
 All construction joints shall be bonded.
 Plan dimensions and details relative to the existing structure are subject to nominal variations. It shall be the Contractor's responsibility to verify such dimensions and details in the field and make necessary approved adjustments prior to construction or ordering of materials. Such variations shall not be cause for additional compensation for a change in the scope of the work, however, the Contractor will be paid for the quantity actually furnished at the unit price for the work.
 The Precast Alternate is not allowed.

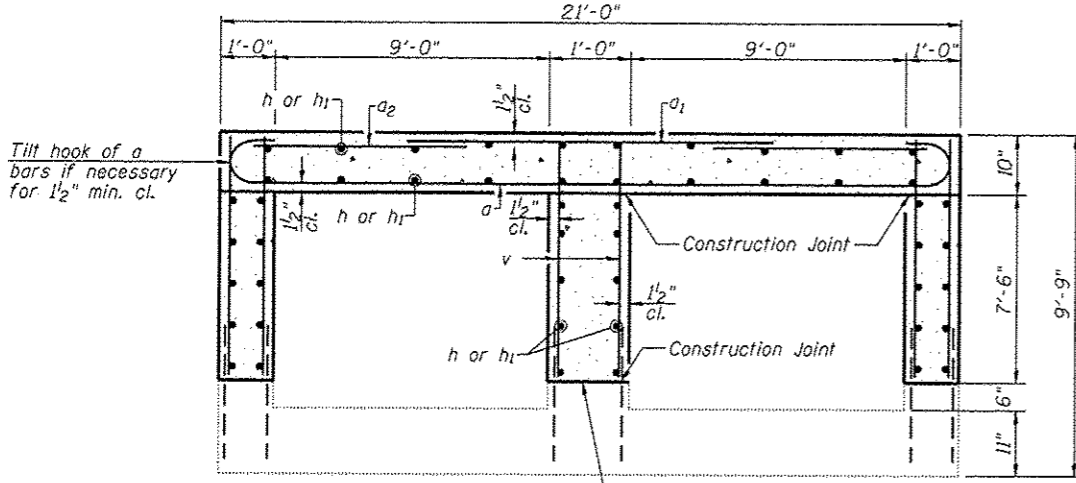

SECTION THRU BARRELL AT EXISTING CULVERT

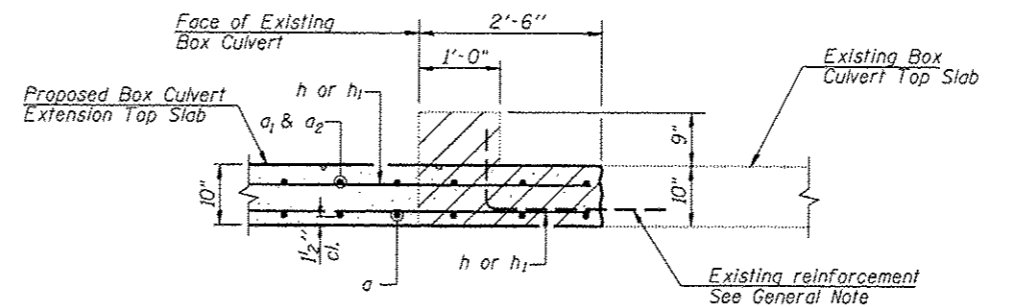

DETAIL A

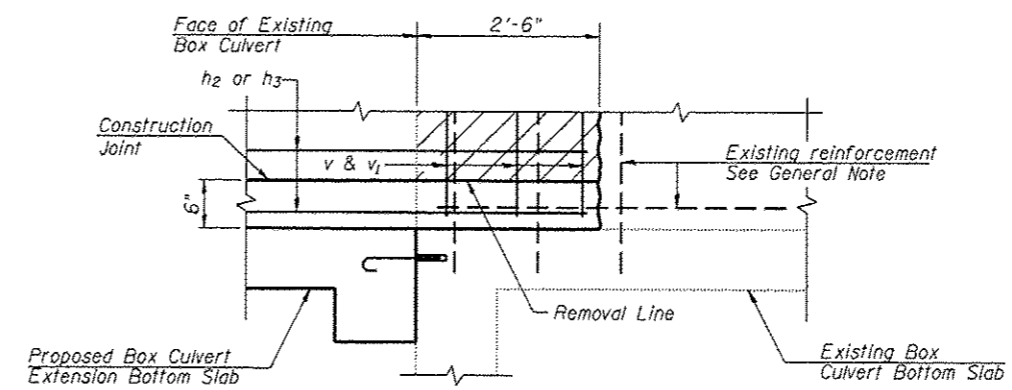

DETAIL B

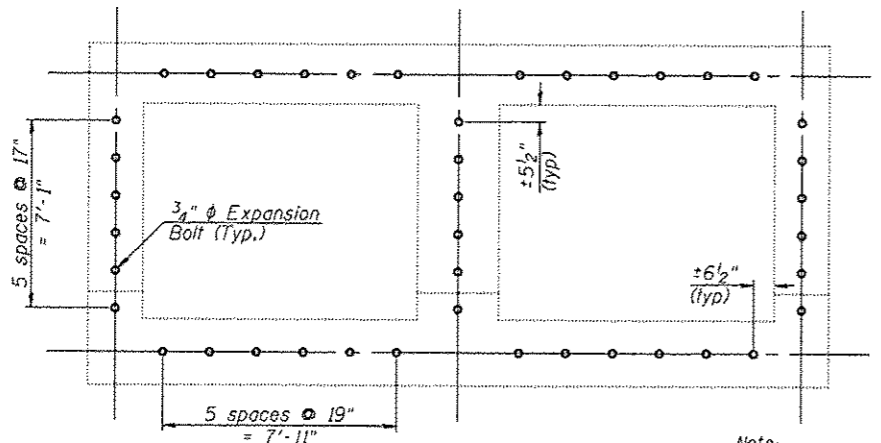

EXISTING END VIEW

(Showing Placement of 3/4" φ Expansion Bolts)

Note: Expansion bolts shall be 3/4" φ hooked bolts. Hooked bolts shall extend a minimum of 9" into new concrete.

BILL OF MATERIAL

Bar	No.	Size	Length	Shape
a	38	#6	23'-1"	U
a1	38	#7	10'-10"	U
a2	40	#5	7'-0"	U
d	38	#4	4'-6"	U
h	90	#5	9'-11"	U
h1	90	#5	6'-11"	U
h2	42	#5	7'-5"	U
h3	42	#5	4'-5"	U
h4	10	#7	20'-9"	U
h5	4	#7	19'-10"	U
h6	30	#8	8'-0"	U
h7	30	#9	8'-0"	U
h8	20	#8	13'-2"	U
h9	20	#9	17'-0"	U
s	63	#4	4'-9"	□
s1	21	#4	4'-7"	□
v	126	#4	7'-11"	U
v1	108	#4	2'-2"	U
v2	16	#4	12'-4"	U
Concrete Removal			Cu. Yd.	7.83
Concrete Box Culverts			Cu. Yd.	58.4
Reinforcement Bars			Pound	9760
Expansion Bolts 3/4" x 12"			Each	84

FINISHED SURVEY	BY	DATE
PLOTTED		
NOTE BOOK		
AREAS CHECKED		

ORIGINAL SURVEY	BY	DATE
PLOTTED		
NOTE BOOK		
AREAS CHECKED		

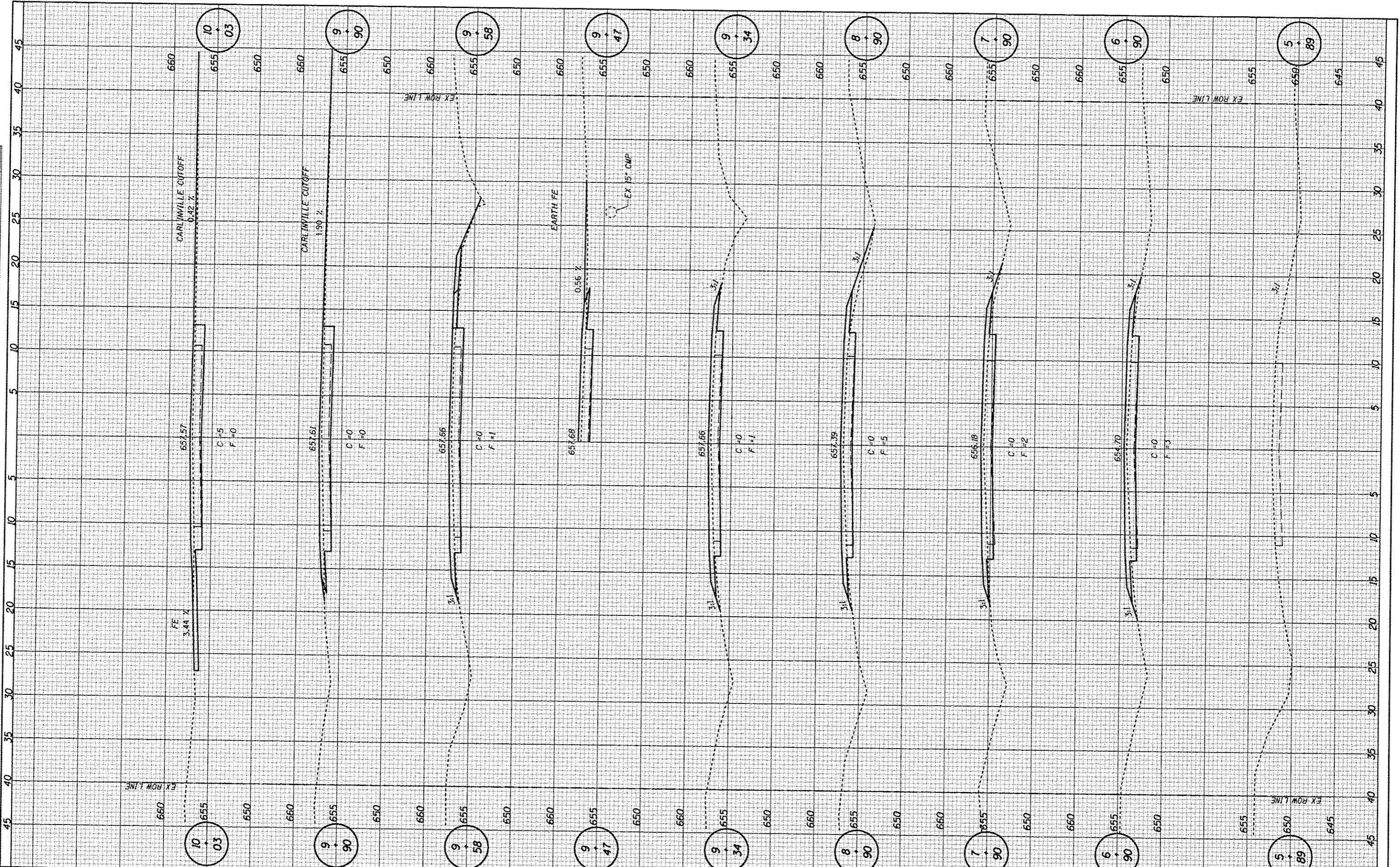

CEC Cummins
Engineering
Corporation
Civil and Structural Engineering

JOB # 2184
FILE NAME = 2184xxx.dgn
PLOT SCALE = 10,0000 x f / IN.
PLOT DATE = 11/21/2013

DESIGNED - NAK
DRAWN - TJD
CHECKED - NAK
DATE - 10/15/2010

REVISED -
REVISED -
REVISED -
REVISED -

**MACOUPIN COUNTY
CH 12 IMPROVEMENTS**

CROSS SECTIONS

SCALE: SHEET NO. OF SHEETS STA. TO STA.

F.A.S. RTE.	SECTION	COUNTY	TOTAL SHEETS	SHEET NO.
732	01-00079-00-FP	MACOUPIN	141	79
CONTRACT NO. 93574				
FED. ROAD DIST. NO. ILLINOIS FED. AID PROJECT				

FINAL SURVEY	DATE
PLOTTED	
NOTE BOOK	
AREAS CHECKED	

ORIGINAL SURVEY	DATE
PLOTTED	
NOTE BOOK	
AREAS CHECKED	

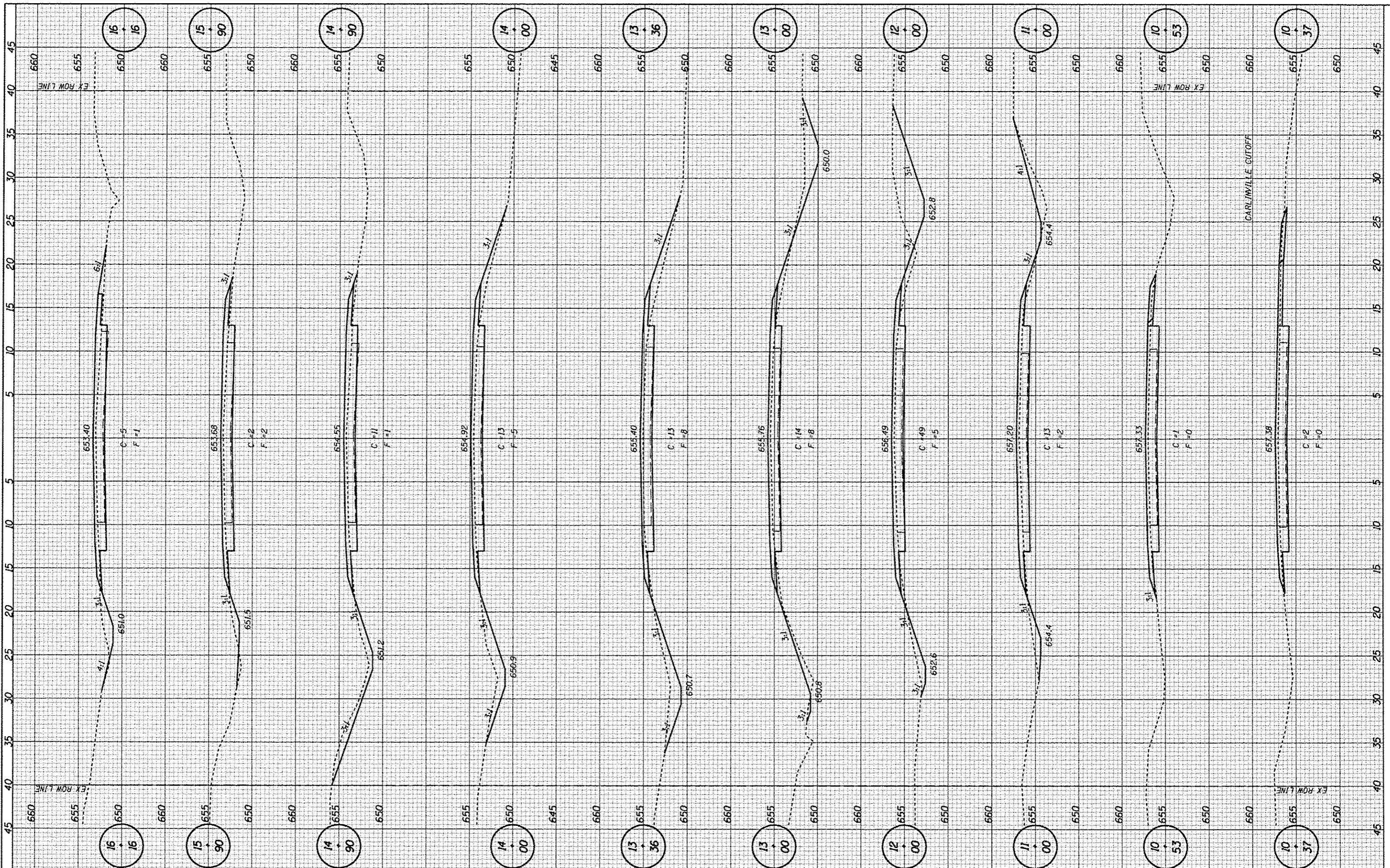

CEC Cummins Engineering Corporation
Civil and Structural Engineering

JOB # 2184
FILE NAME = 2184\ss0.dgn
PLOT SCALE = 10.0000" = 1'
DATE = 11/21/2013

DESIGNED - NAK
DRAWN - TJD
CHECKED - NAK
DATE - 10/15/2010

REVISED -
REVISED -
REVISED -
REVISED -

**MACOUPIN COUNTY
CH 12 IMPROVEMENTS**

CROSS SECTIONS

SCALE: SHEET NO. OF SHEETS STA. TO STA.

F.A.S. RTE. 732	SECTION 01-00079-00-FP	COUNTY MACOUPIN	TOTAL SHEETS 141	SHEET NO. 80
CONTRACT NO. 93574				
FED. ROAD DIST. NO. ILLINOIS FED. AID PROJECT				

FINAL SURVEY	DATE
REVISED	BY
NOTE BOOK	NO.
TEMPLATE	AREAS CHECKED

ORIGINAL SURVEY	DATE
REVISED	BY
NOTE BOOK	NO.
TEMPLATE	AREAS CHECKED

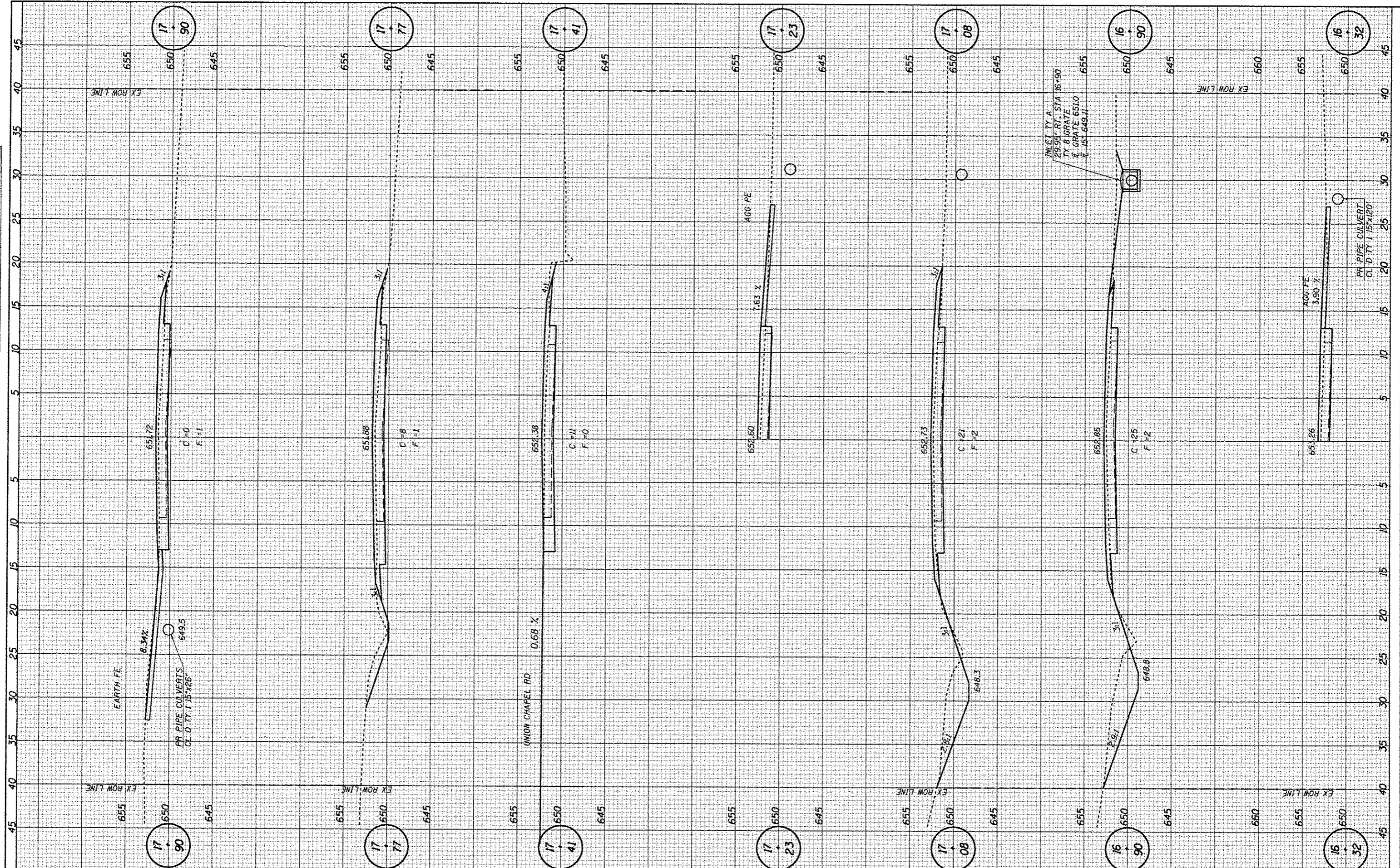

CEC Cummins
Engineering Corporation
Civil and Structural Engineering

JOB = 2184
FILE NAME = 2184.cad.dgn
PLOT SCALE = 10.0000" = 1' IN.
PLOT DATE = 11/21/2013

DESIGNED - NAK
DRAWN - TJD
CHECKED - NAK
DATE - 10/15/2010

REVISED -
REVISED -
REVISED -
REVISED -

**MACOUPIN COUNTY
CH 12 IMPROVEMENTS**

CROSS SECTIONS

SCALE: SHEET NO. OF SHEETS STA. TO STA.

F.A.S. RTE. 732	SECTION 01-00079-00-FP	COUNTY MACOUPIN	TOTAL SHEETS 141	SHEET NO. 81
FED. ROAD DIST. NO.		ILLINOIS FED. AID PROJECT		CONTRACT NO. 93574

FINAL SURVEY	SURVEYED	BY	DATE
NOTE BOOK	PLOTTED		
NO.	TEMPLATE		
	AREAS		
	CHECKED		

ORIGINAL SURVEY	SURVEYED	BY	DATE
NOTE BOOK	PLOTTED		
NO.	TEMPLATE		
	AREAS		
	CHECKED		

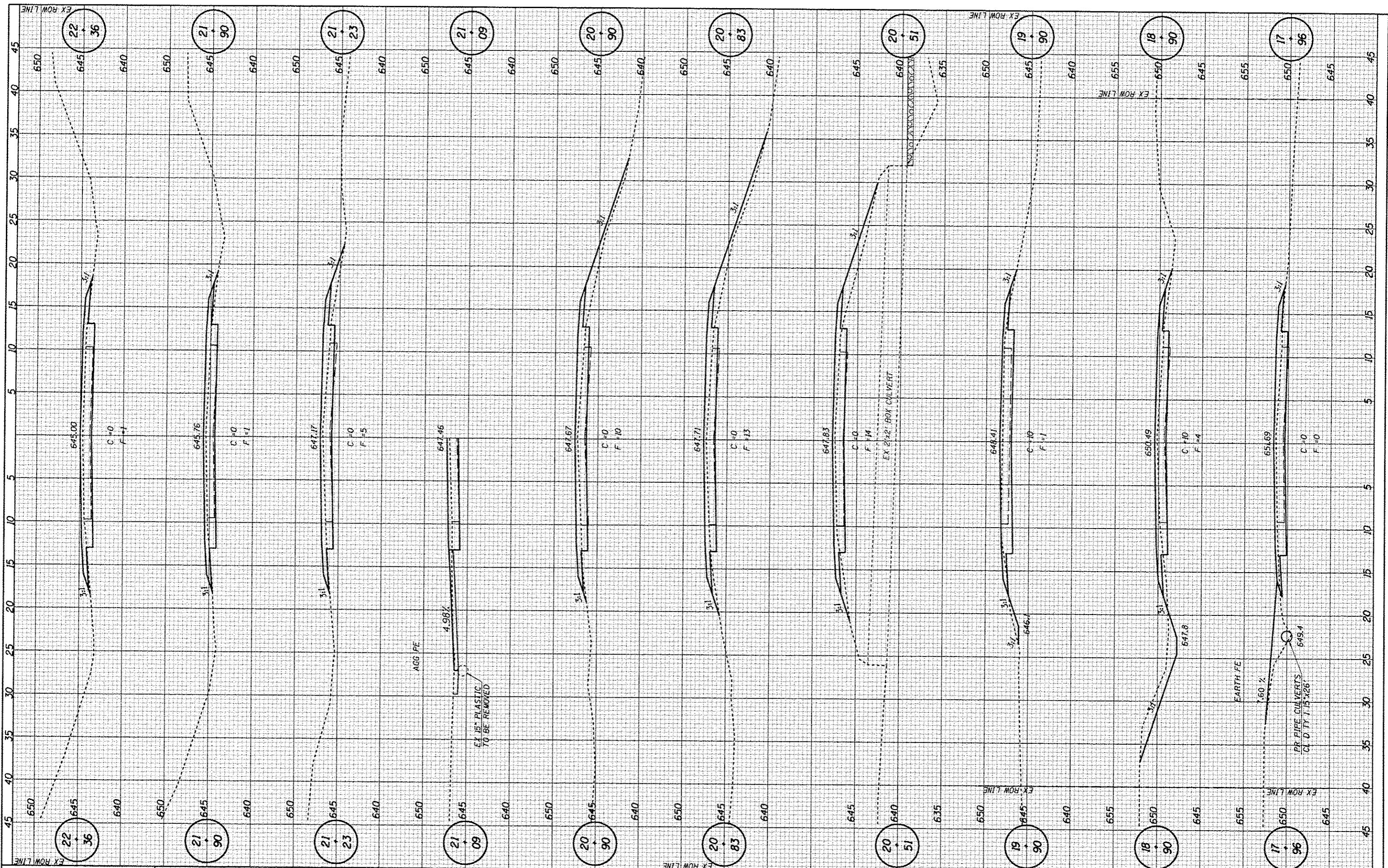

CEC Cummins Engineering Corporation
Civil and Structural Engineering

JOB # 2184
FILE NAME = 2184.dwg
PLOT SCALE = 1/8" = 1' / IN.
PLOT DATE = 12/5/2013

DESIGNED - NAK
DRAWN - TJD
CHECKED - NAK
DATE - 10/15/2010

REVISED -
REVISED -
REVISED -
REVISED -

**MACOUPIN COUNTY
CH 12 IMPROVEMENTS**

CROSS SECTIONS

SCALE: SHEET NO. OF SHEETS STA. TO STA.

F.A.S. RTE. 732	SECTION 01-00079-00-FP	COUNTY MACOUPIN	TOTAL SHEETS 141	SHEET NO. 82
FED. ROAD DIST. NO.		ILLINOIS FED. AID PROJECT		
CONTRACT NO. 935174				

FINAL	STARTED	BY	DATE
SURVEY	PLOTTED		
NOTE BOOK	TEMPLATE		
NO.	AREAS CHECKED		

ORIGINAL	STARTED	BY	DATE
SURVEY	PLOTTED		
NOTE BOOK	TEMPLATE		
NO.	AREAS CHECKED		

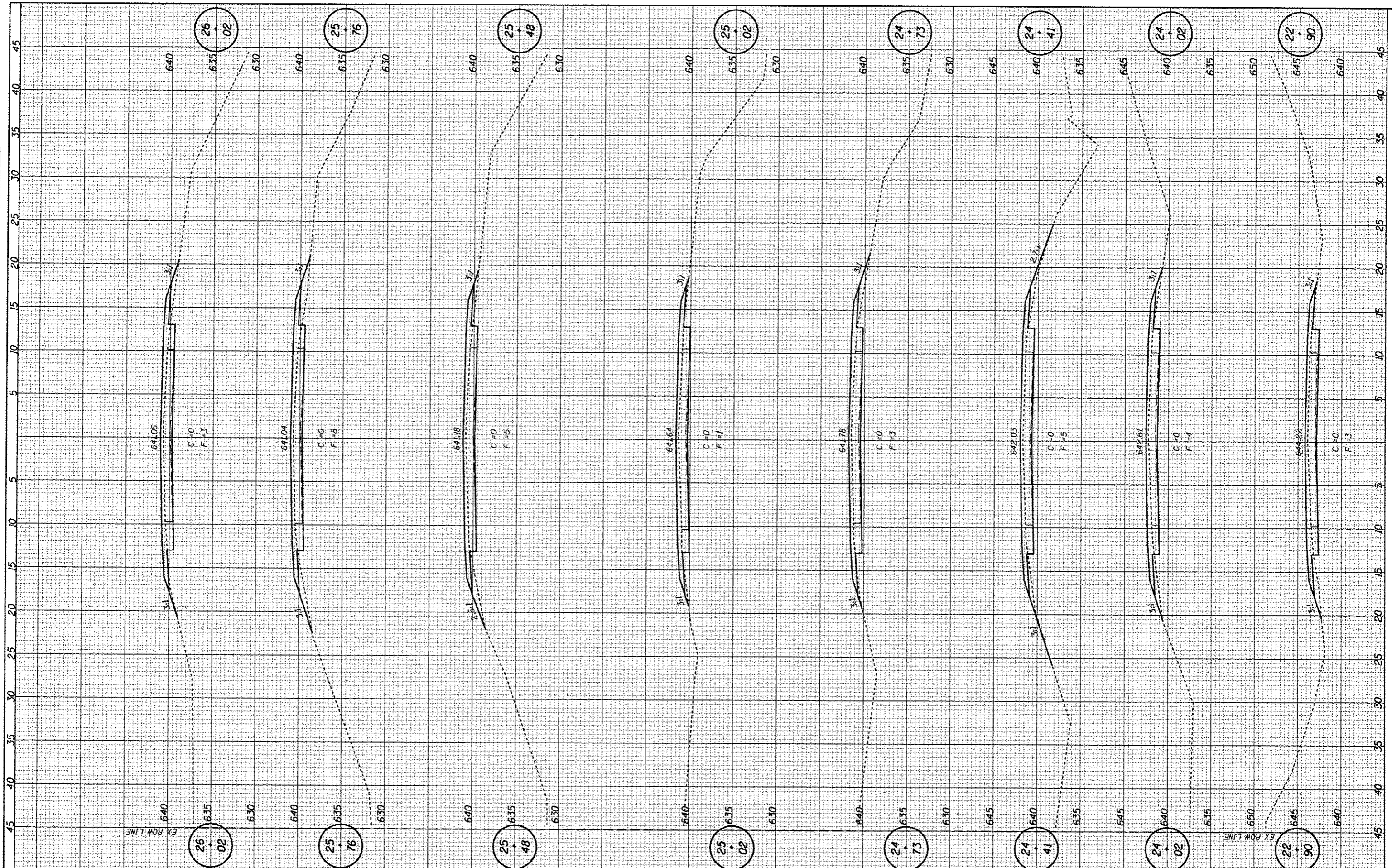

CEC Cummins
Engineering
Corporation
Civil and Structural Engineering

JOB = 2184
FILE NAME = 2184\waco.dgn
PLOT SCALE = 10.0000 x / IN.
PLOT DATE = 11/21/2013

DESIGNED - NAK
DRAWN - TJD
CHECKED - NAK
DATE - 10/15/2010

REVISED -
REVISED -
REVISED -
REVISED -

**MACOUPIN COUNTY
CH 12 IMPROVEMENTS**

CROSS SECTIONS

SCALE: SHEET NO. OF SHEETS STA. TO STA.

F.A.S. RTE. 732	SECTION 01-00079-00-FP	COUNTY MACOUPIN	TOTAL SHEETS 141	SHEET NO. 83
FED. ROAD DIST. NO.		ILLINOIS FED. AID PROJECT		
CONTRACT NO. 93574				

FINAL SURVEY	DATE
SURVEYED	BY
PLOTTED	
TEMPLATE	
NOTE BOOK	
NO.	

ORIGINAL SURVEY	DATE
SURVEYED	BY
PLOTTED	
TEMPLATE	
NOTE BOOK	
NO.	

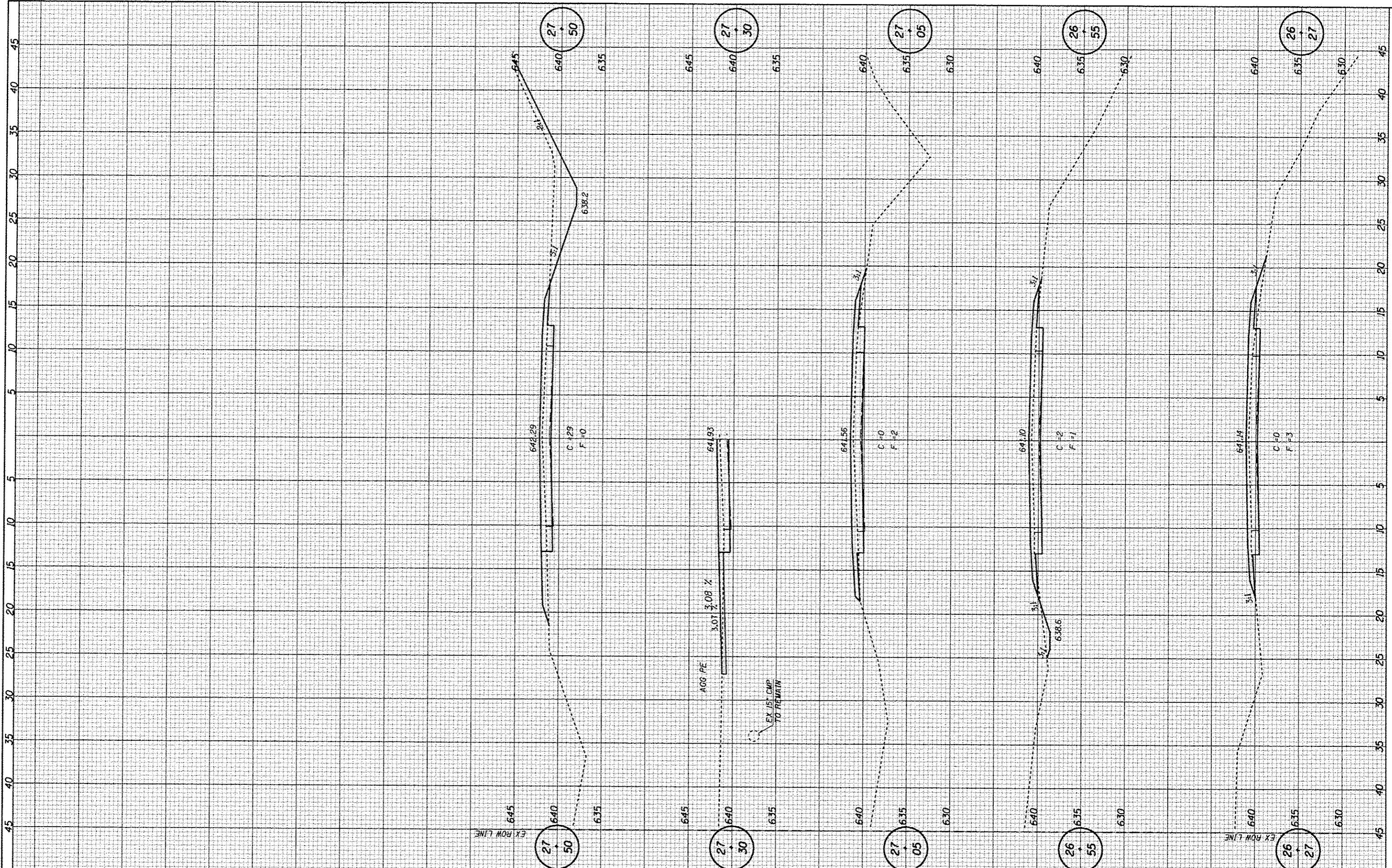

CEC Cummins Engineering Corporation
Civil and Structural Engineering

JOB = 2184
FILE NAME = 2184***.dgn
PLOT SCALE = 1/8" = 1'-0"
PLOT DATE = 11/21/2013

DESIGNED - NAK
DRAWN - TJD
CHECKED - NAK
DATE - 10/15/2010

REVISED -
REVISED -
REVISED -
REVISED -

**MACOUPIN COUNTY
CH 12 IMPROVEMENTS**

CROSS SECTIONS

SCALE: SHEET NO. OF SHEETS STA. TO STA.

F.A.S. RTE.	SECTION	COUNTY	TOTAL SHEETS	SHEET NO.
732	01-00079-00-FP	MACOUPIN	141	84
FED. ROAD DIST. NO.		ILLINOIS FED. AID PROJECT		
		CONTRACT NO. 93574		

FINI	DATE
SURVEY	
NOTED	
PLOTTED	
TEMPLATE	
AREAS	
CHECKED	

ORIGINAL	DATE
SURVEY	
NOTED	
PLOTTED	
TEMPLATE	
AREAS	
CHECKED	

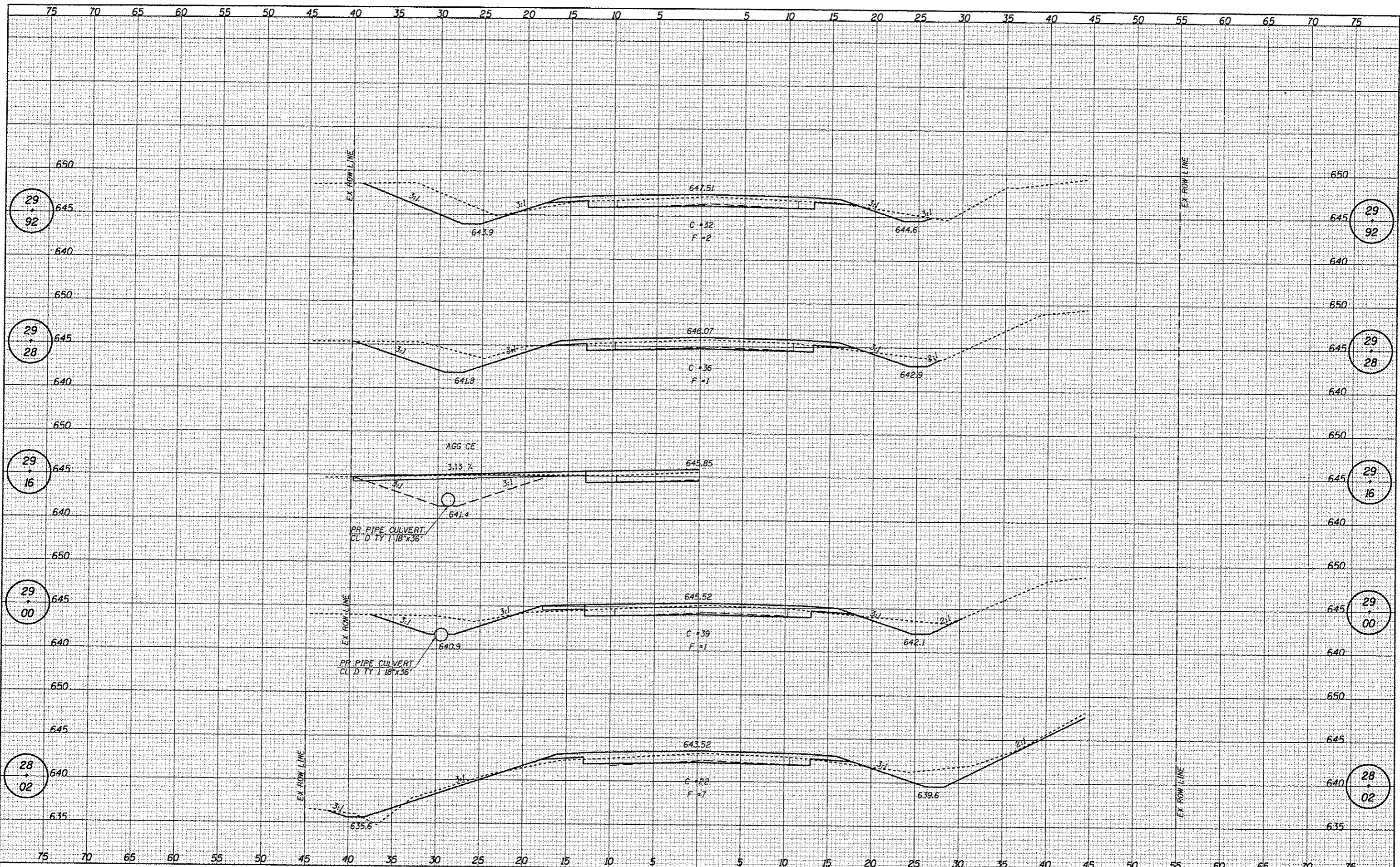

CEC Cummins Engineering Corporation
Civil and Structural Engineering

JOB # 2184
FILE NAME = 2184***.dgn
PLOT SCALE = 10.0000' = 1" IN.
PLOT DATE = 11/21/2013

DESIGNED - NAK
DRAWN - TJD
CHECKED - NAK
DATE - 10/15/2010

REVISED -
REVISED -
REVISED -
REVISED -

**MACOUPIN COUNTY
CH 12 IMPROVEMENTS**

CROSS SECTIONS
SCALE: SHEET NO. OF SHEETS STA. TO STA.

F.A.S. RTE.	SECTION	COUNTY	TOTAL SHEETS	SHEET NO.
732	01-00079-00-FP	MACOUPIN	141	85
CONTRACT NO. 93574				
FED. ROAD DIST. NO. ILLINOIS FED. AID PROJECT				

DATE	
BY	
FINAL SURVEY	
ADJUSTED	
NOTED	
TEMPLATE	
AREAS	
CHECKED	
NO.	

DATE	
BY	
ORIGINAL SURVEY	
ADJUSTED	
NOTED	
TEMPLATE	
AREAS	
CHECKED	
NO.	

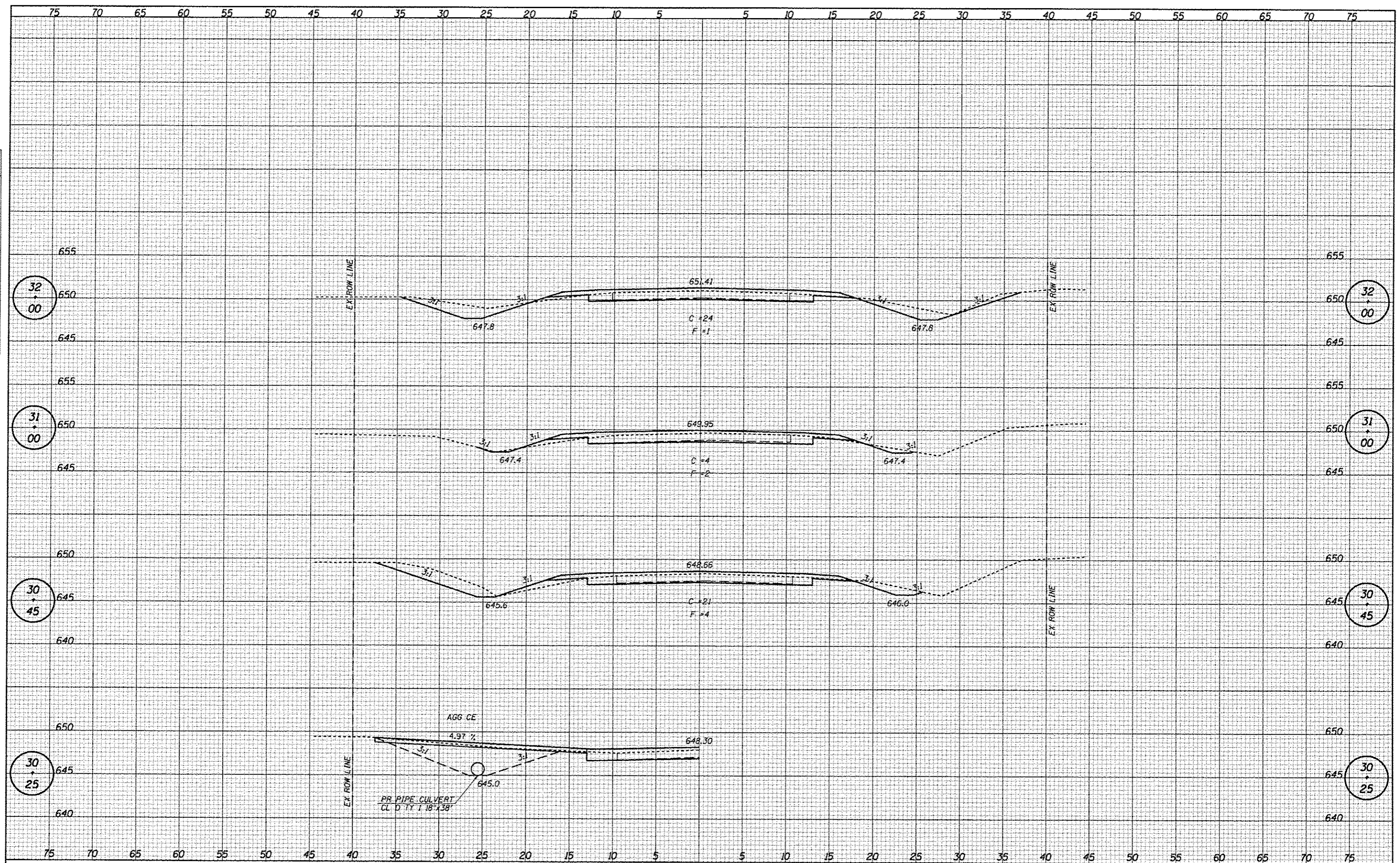

CEC Cummins Engineering Corporation
Civil and Structural Engineering

JOB # 2184
FILE NAME = 2184xxxx.dgn
PLOT SCALE = 10,000 x / IN.
PLOT DATE = 11/21/2013

DESIGNED - NAK
DRAWN - TJD
CHECKED - NAK
DATE - 10/15/2010

REVISED -
REVISED -
REVISED -
REVISED -

**MACOUPIN COUNTY
CH 12 IMPROVEMENTS**

CROSS SECTIONS

SCALE: SHEET NO. OF SHEETS STA. TO STA.

F.A.S. RTE.	SECTION	COUNTY	TOTAL SHEETS	SHEET NO.
732	01-00079-00-FP	MACOUPIN	141	86
FED. ROAD DIST. NO. ILLINOIS FED. AID PROJECT			CONTRACT NO. 93574	

FINAL SURVEY	BY	DATE
SURVEYED		
PLOTTED		
NOTE BOOK		
AREAS		
AREAS CHECKED		

ORIGINAL SURVEY	BY	DATE
SURVEYED		
PLOTTED		
NOTE BOOK		
AREAS		
AREAS CHECKED		

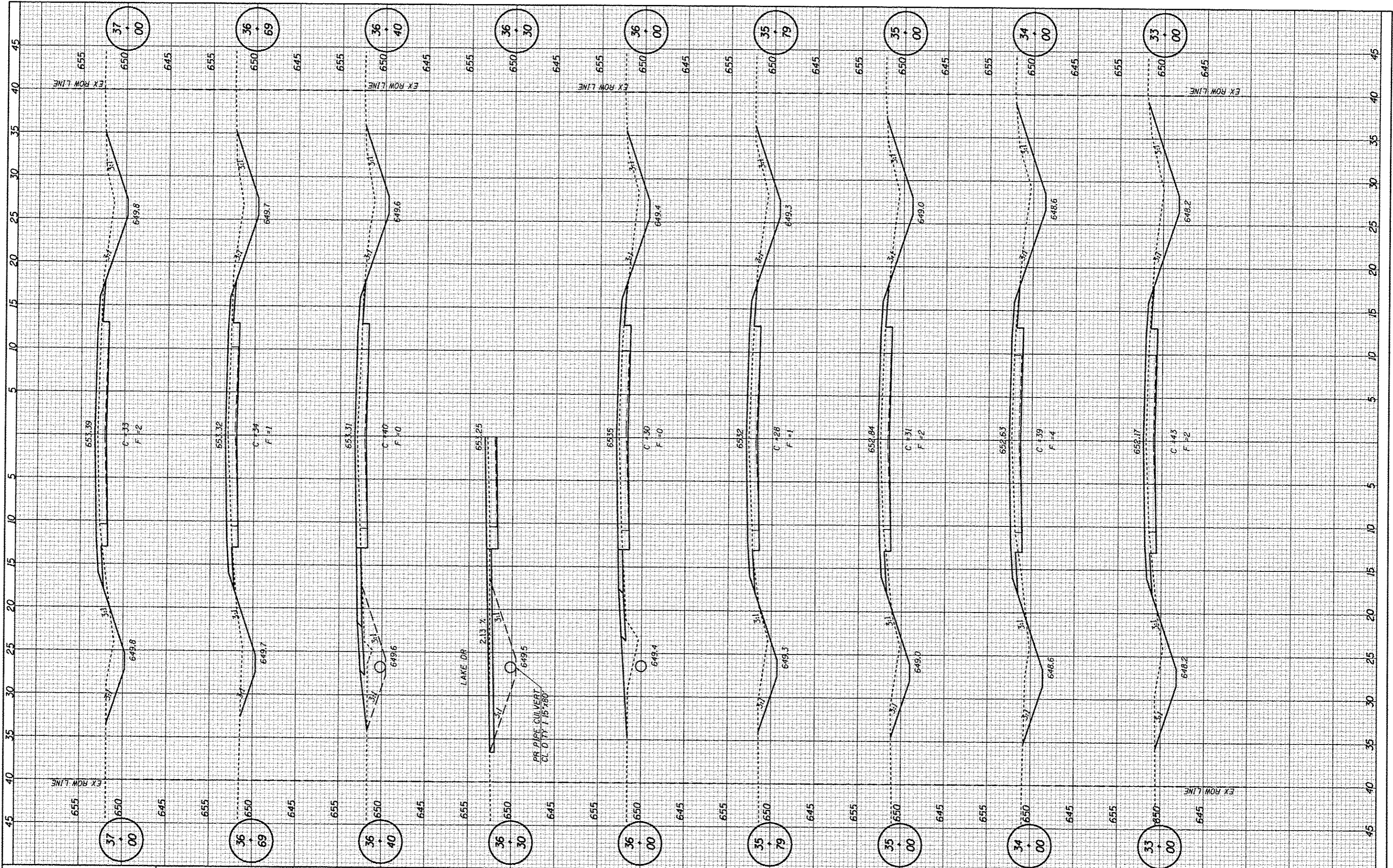

JOB # 2184
 FILE NAME = 2184.ras.dgn
 PLOT SCALE = 10.0000 x / IN.
 PLOT DATE = 11/21/2013

DESIGNED - NAK
 DRAWN - TJO
 CHECKED - NAK
 DATE - 10/15/2010

REVISED -
 REVISED -
 REVISED -
 REVISED -

**MACOUPIN COUNTY
 CH 12 IMPROVEMENTS**

CROSS SECTIONS

SCALE: SHEET NO. OF SHEETS STA. TO STA.

F.A.S. RTE. 732	SECTION 01-00079-00-FP	COUNTY MACOUPIN	TOTAL SHEETS 141	SHEET NO. 87
FED. ROAD DIST. NO. [ILLINOIS] FED. AID PROJECT		CONTRACT NO. 93574		

FINAL	BY	DATE
SURVEY		
NOTED		
PLOTTED		
TEMPLATE		
AREAS		
CHECKED		

ORIGINAL	BY	DATE
SURVEY		
NOTED		
PLOTTED		
TEMPLATE		
AREAS		
CHECKED		

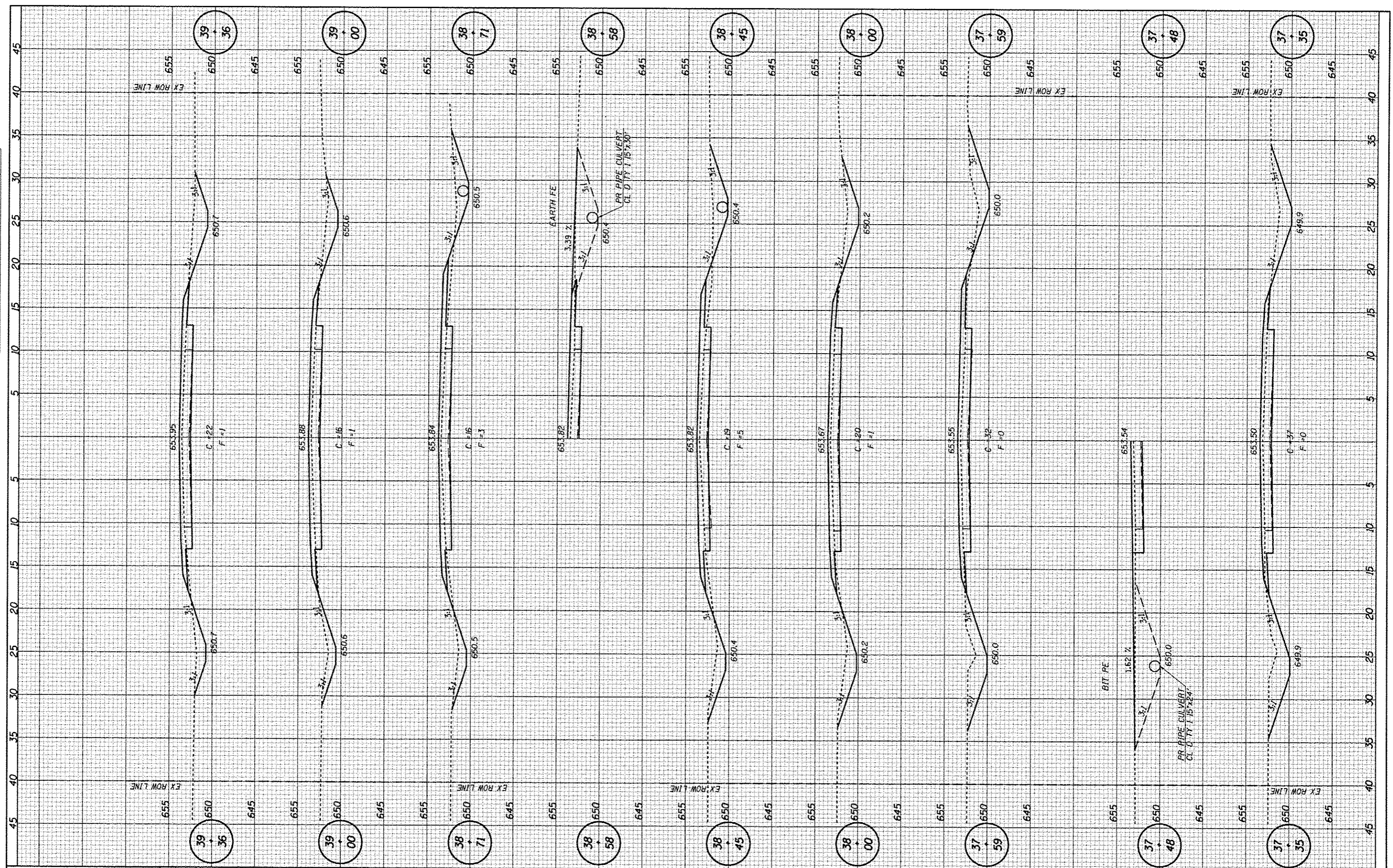

JOB = 2184
 FILE NAME = 2184secc.dgn
 PLOT SCALE = 10.0000 sf / IN.
 PLOT DATE = 11/21/2013

DESIGNED - NAK
 DRAWN - TJO
 CHECKED - NAK
 DATE - 10/15/2010

REVISED -
 REVISED -
 REVISED -
 REVISED -

**MACOUPIN COUNTY
 CH 12 IMPROVEMENTS**

CROSS SECTIONS

SCALE: SHEET NO. OF SHEETS STA. TO STA.

F.A.S. RTE. 732	SECTION 01-0079-00-FP	COUNTY MACOUPIN	TOTAL SHEETS 141	SHEET NO. 88
FED. ROAD DIST. NO. [ILLINOIS] FED. AID PROJECT			CONTRACT NO. 93574	

FINAL SURVEY	SURVEYED	BY	DATE
NOTE BOOK NO.	PLOTTED		
	TEMPLATE		
	AREAS CHECKED		

ORIGINAL SURVEY	SURVEYED	BY	DATE
NOTE BOOK NO.	PLOTTED		
	TEMPLATE		
	AREAS CHECKED		

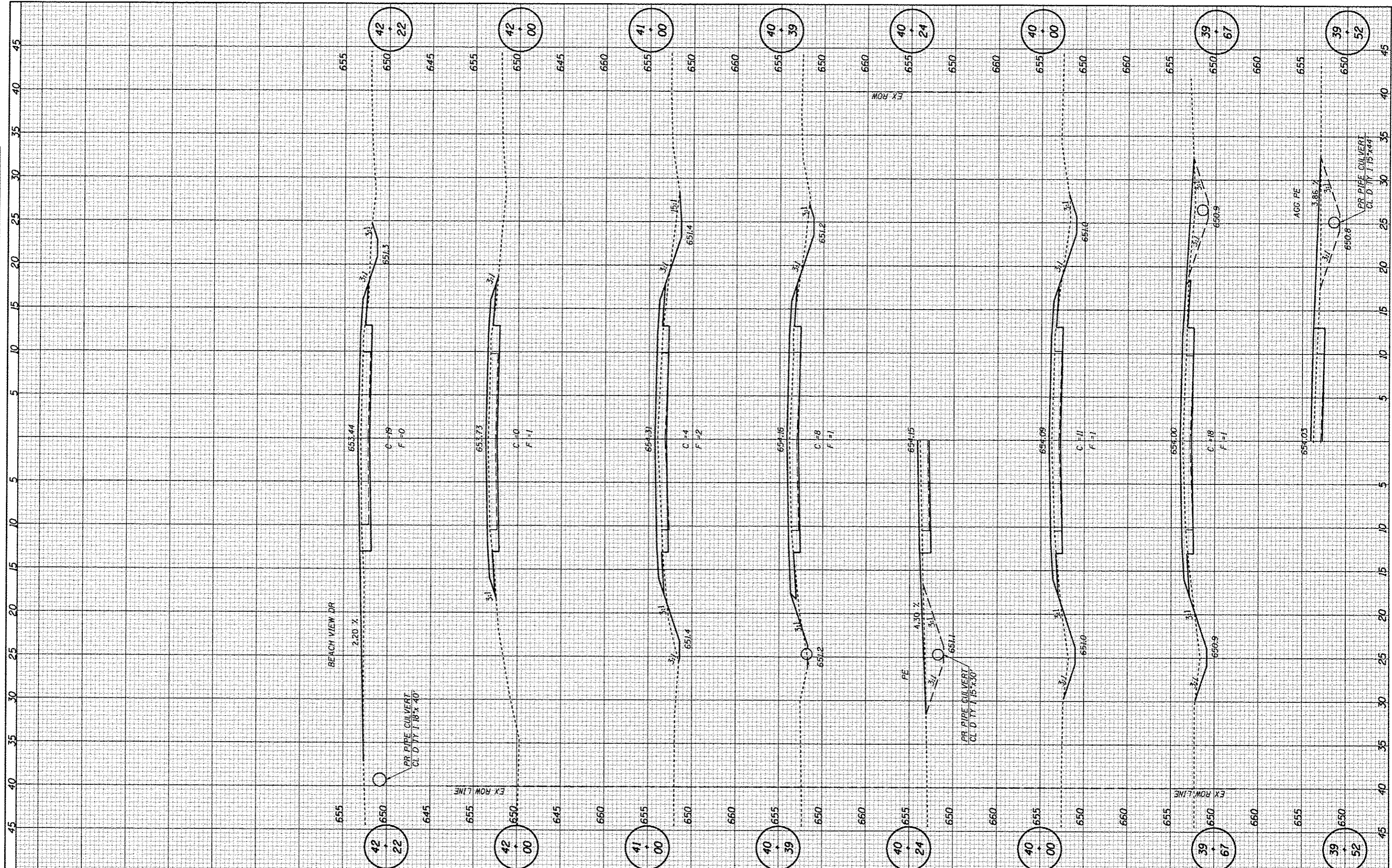

JOB #	2184	DESIGNED	- NAK	REVISED	-
FILE NAME	2184.sao.dgn	DRAWN	- TJD	REVISED	-
PLDT SCALE	18.0000 # / IN.	CHECKED	- NAK	REVISED	-
PLDT DATE	11/21/2013	DATE	- 10/15/2010	REVISED	-

**MACOUPIN COUNTY
CH 12 IMPROVEMENTS**

CROSS SECTIONS

SCALE: SHEET NO. OF SHEETS STA. TO STA.

F.A.S. RTE.	SECTION	COUNTY	TOTAL SHEETS	SHEET NO.
732	01-00079-00-FP	MACOUPIN	141	89
FED. ROAD DIST. NO.		ILLINOIS FED. AID PROJECT		CONTRACT NO. 93574

DATE	
BY	
FINAL SURVEY	
SURVEY	
NOTE BOOK	
TEMPLATE	
AREAS CHECKED	
NO.	

DATE	
BY	
ORIGINAL SURVEY	
SURVEY	
NOTE BOOK	
TEMPLATE	
AREAS CHECKED	
NO.	

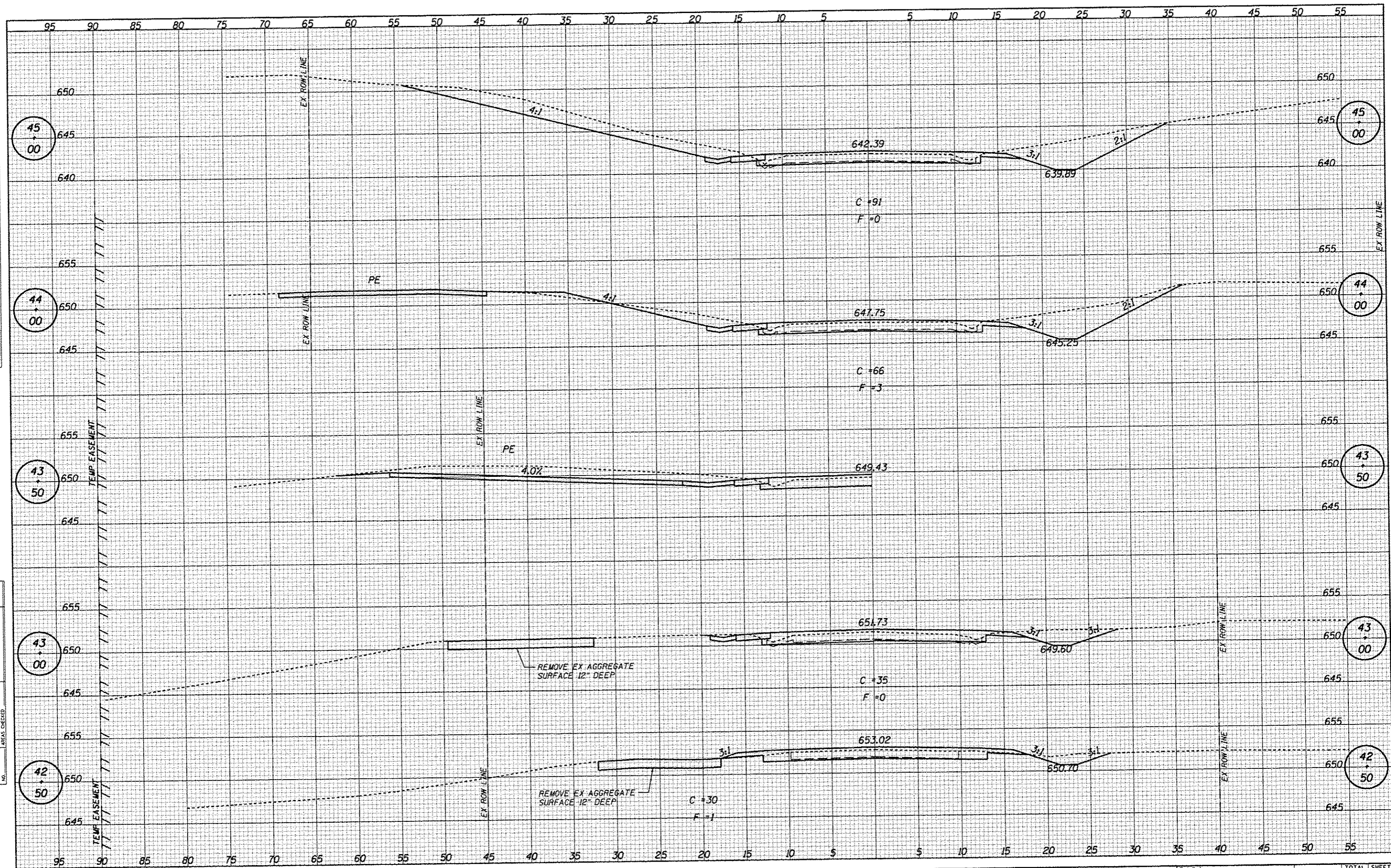

JOB # 2184
 FILE NAME # 2184\secc.dgn
 PLOT SCALE = 10.0000 sf / in.
 PLOT DATE = 11/21/2013

DESIGNED - NAK
 DRAWN - TJD
 CHECKED - NAK
 DATE - 10/15/2010

REVISED -
 REVISED -
 REVISED -
 REVISED -

**MACOUPIN COUNTY
 CH 12 IMPROVEMENTS**

CROSS SECTIONS

SCALE: SHEET NO. OF SHEETS STA. TO STA.

F.A.S. RTE.	SECTION	COUNTY	TOTAL SHEETS	SHEET NO.
732	01-00079-00-FP	MACOUPIN	141	90
FED. ROAD DIST. NO.		ILLINOIS FED. AID PROJECT		
		CONTRACT NO. 93574		

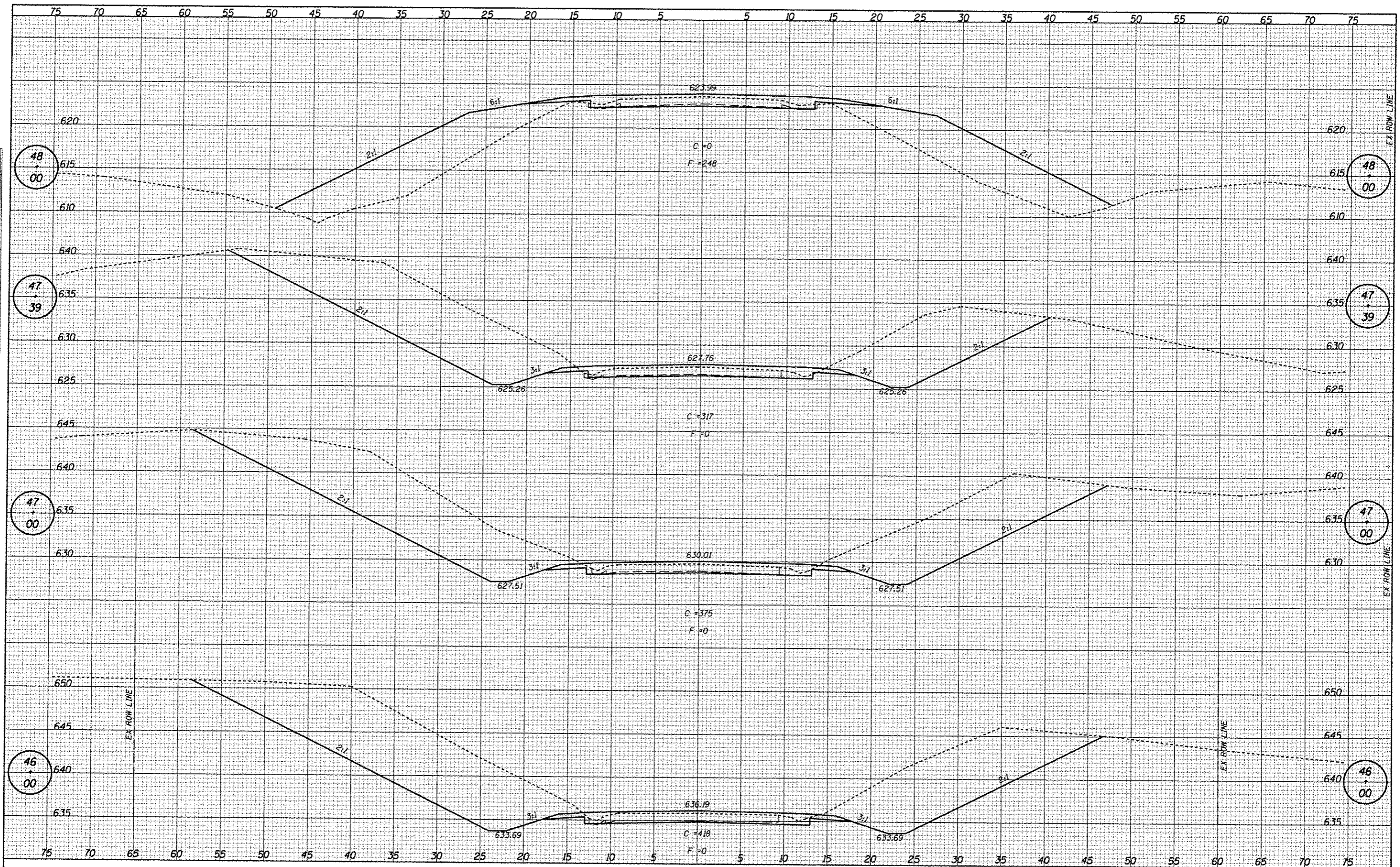

DATE	
BY	
CHECKED	
DESIGNED	
PLANNED	
NOTED	
AREAS CHECKED	
NO.	

DATE	
BY	
CHECKED	
DESIGNED	
PLANNED	
NOTED	
AREAS CHECKED	
NO.	

CEC Cummins
Engineering
Corporation
Civil and Structural Engineering

JOB = 2184
FILE NAME = 2184xxxx.dgn
PLOT SCALE = 10.0000 x F / IN.
PLOT DATE = 11/21/2013

DESIGNED - NAK
DRAWN - TJD
CHECKED - NAK
DATE - 10/15/2010

REVISED -
REVISED -
REVISED -
REVISED -

**MACOUPIN COUNTY
CH 12 IMPROVEMENTS**

CROSS SECTIONS
SCALE: SHEET NO. OF SHEETS STA. TO STA.

F.A.S. RTE.	SECTION	COUNTY	TOTAL SHEETS	SHEET NO.
732	01-00079-00-FP	MACOUPIN	141	91
FED. ROAD DIST. NO.		ILLINOIS FED. AID PROJECT		
		CONTRACT NO. 93574		

DATE
BT
SURVEYED
PLOTTED
NOTE BOOK
AREAS CHECKED

DATE
BT
SURVEYED
PLOTTED
NOTE BOOK
AREAS CHECKED

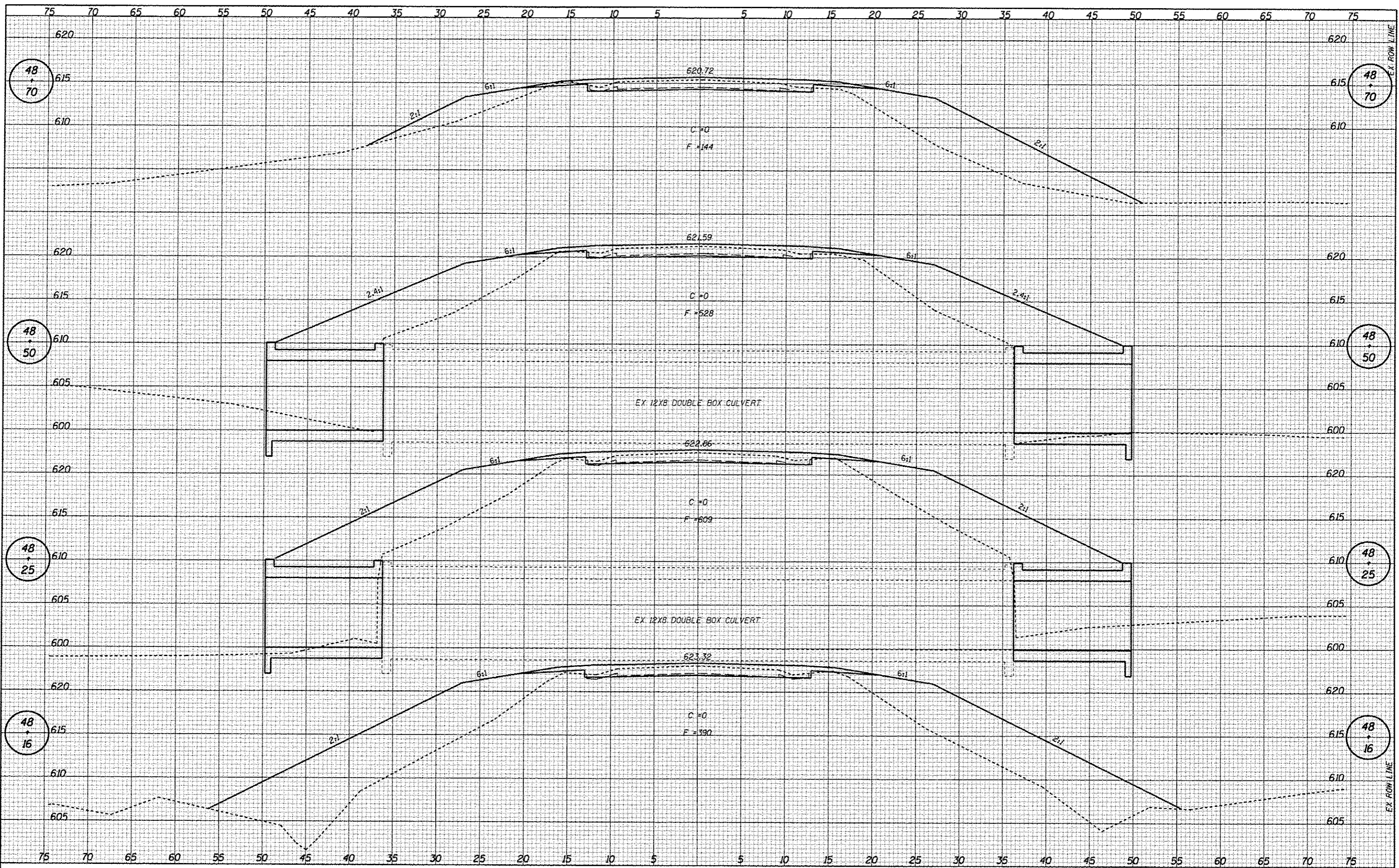

CEC Cummins Engineering Corporation
Civil and Structural Engineering

JOB # 2184	DESIGNED - NAK	REVISED -
FILE NAME = 2184xsec.dgn	DRAWN - TJD	REVISED -
PLOT SCALE = 10,0000 x' / IN.	CHECKED - NAK	REVISED -
PLOT DATE = 11/21/2013	DATE - 10/15/2010	REVISED -

**MACOUPIN COUNTY
CH 12 IMPROVEMENTS**

CROSS SECTIONS

SCALE:	SHEET NO. OF SHEETS	STA. TO STA.
--------	---------------------	--------------

F.A.S. RTE. 732	SECTION 01-00079-00-PP	COUNTY MACOUPIN	TOTAL SHEETS 141	SHEET NO. 92
CONTRACT NO. 93574				
FED. ROAD DIST. NO. [ILLINOIS] FED. AID PROJECT				

DATE	
BY	
FINAL SURVEY	
PLOTTED	
NOTE BOOK	
AREAS CHECKED	
NO.	

DATE	
BY	
ORIGINAL SURVEY	
PLOTTED	
NOTE BOOK	
AREAS CHECKED	
NO.	

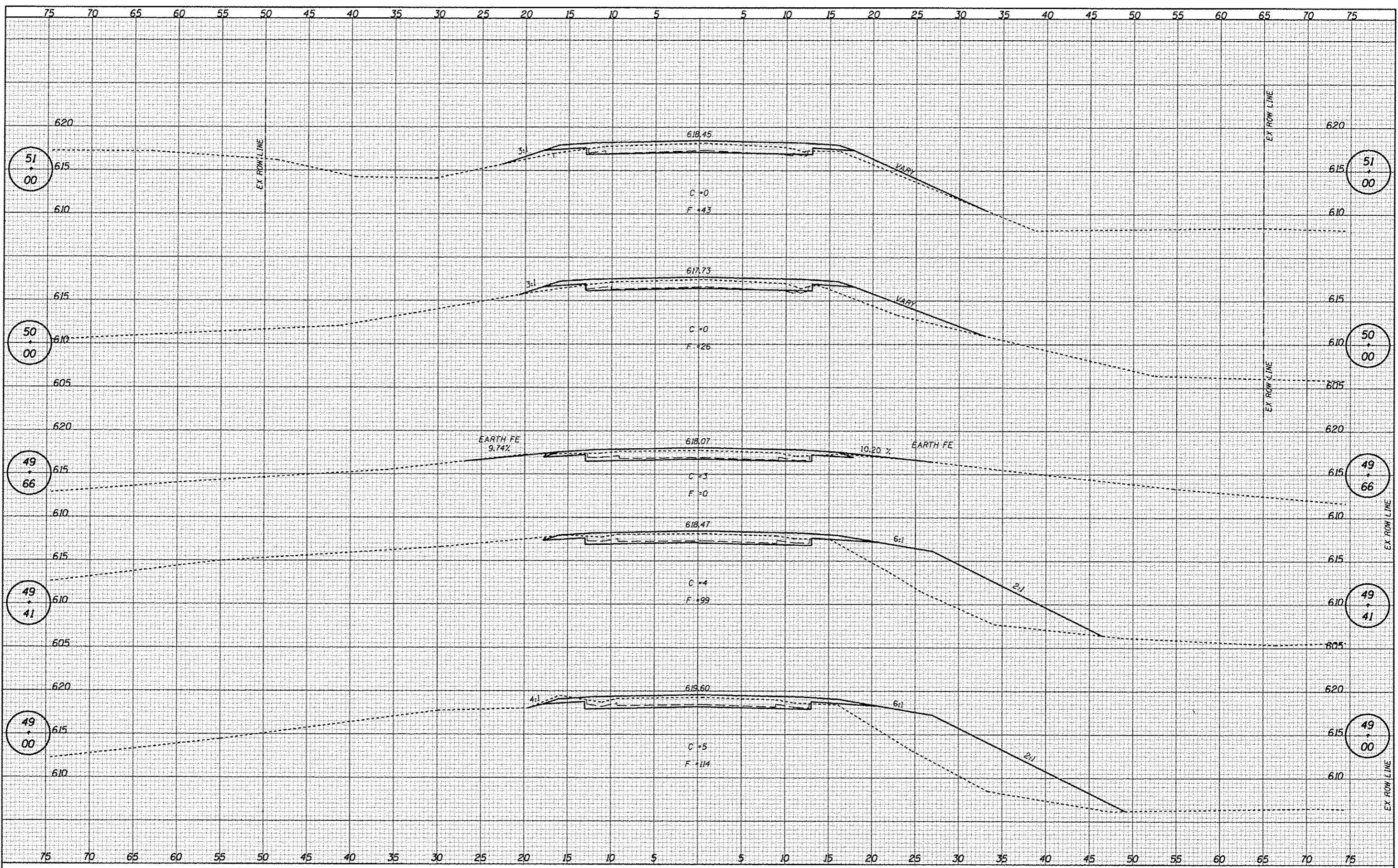

JOB # 2184
 FILE NAME = 2184.xxxx.dgn
 PLOT SCALE = 10.0000" = 1' / IN.
 PLOT DATE = 12/5/2013

DESIGNED - NAK
 DRAWN - TJD
 CHECKED - NAK
 DATE - 10/15/2010

REVISED -
 REVISED -
 REVISED -
 REVISED -

**MACOUPIN COUNTY
 CH 12 IMPROVEMENTS**

CROSS SECTIONS

SCALE: SHEET NO. OF SHEETS STA. TO STA.

F.A.S. RTE. 732	SECTION 01-00079-00-FP	COUNTY MACOUPIN	TOTAL SHEETS 141	SHEET NO. 93
FED. ROAD DIST. NO.		ILLINOIS FED. AID PROJECT		

CONTRACT NO. 93574

FINAL	SURVEYED	DATE
SHEET	PLOTTED	BY
NOTE BOOK	TEMPLATE	
NO.	AREAS CHECKED	

ORIGINAL	DATE
SURVEY	BY
PLOTTED	
NOTE BOOK	
NO.	

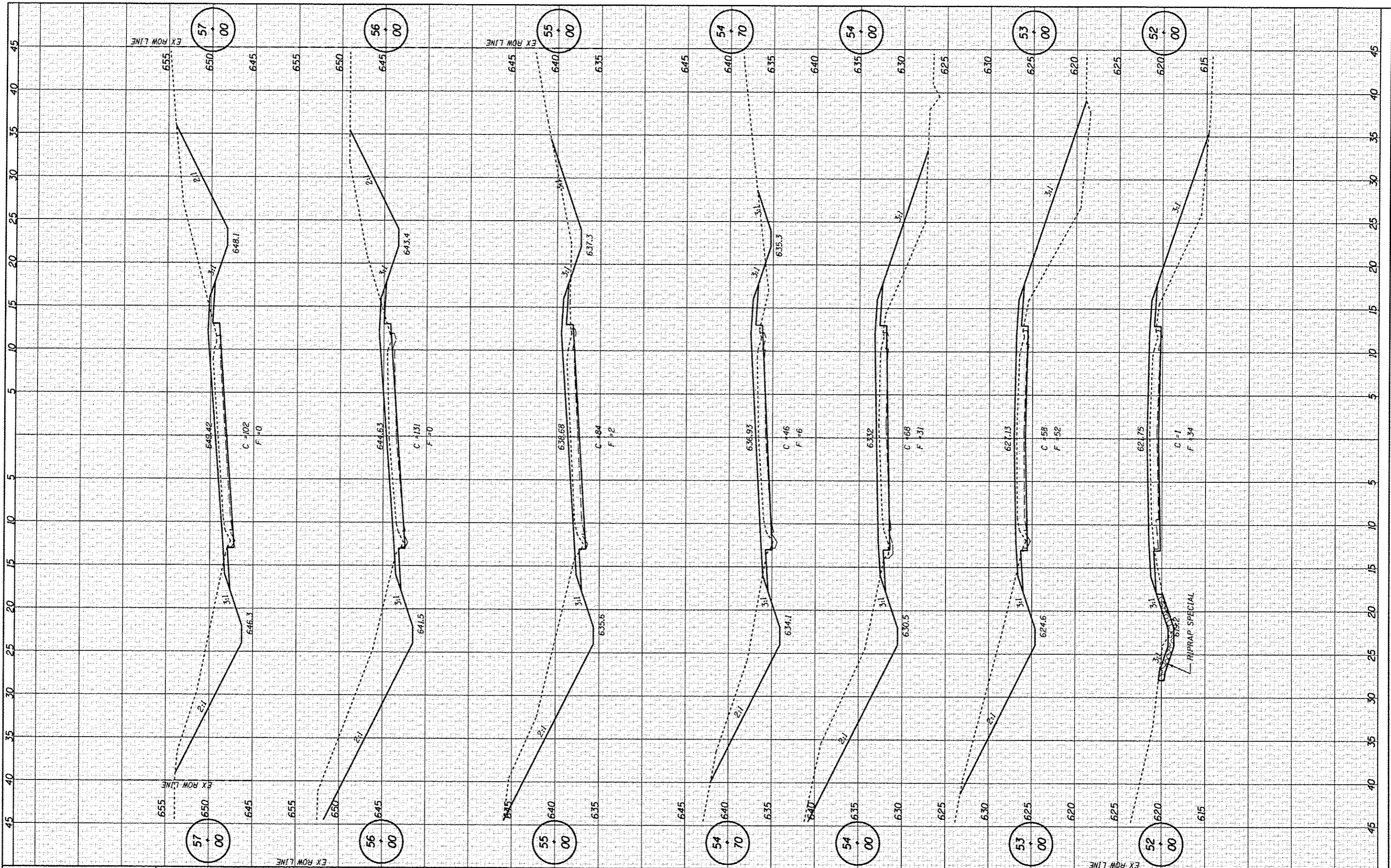

CEC Cummins Engineering Corporation
Civil and Structural Engineering

JOB # 2184
FILE NAME = 2184***.dgn
PLOT SCALE = 10,00000 of 1 IN.
PLOT DATE = 11/22/2013

DESIGNED - NAK
DRAWN - TJD
CHECKED - NAK
DATE - 10/15/2010

REVISED -
REVISED -
REVISED -
REVISED -

**MACOUPIN COUNTY
CH 12 IMPROVEMENTS**

CROSS SECTIONS

SCALE: SHEET NO. OF SHEETS STA. TO STA.

F.A.S. RTE. 732	SECTION 01-00079-00-FP	COUNTY MACOUPIN	TOTAL SHEETS 141	SHEET NO. 94
FED. ROAD DIST. NO. [ILLINOIS] FED. AID PROJECT		CONTRACT NO. 93574		

FINAL SURVEY	DATE
SURVEYED	BY
PLOTTED	DATE
TEMPLATE	
NOTE BOOK	
AREAS CHECKED	

ORIGINAL SURVEY	DATE
SURVEYED	BY
PLOTTED	DATE
TEMPLATE	
NOTE BOOK	
AREAS CHECKED	

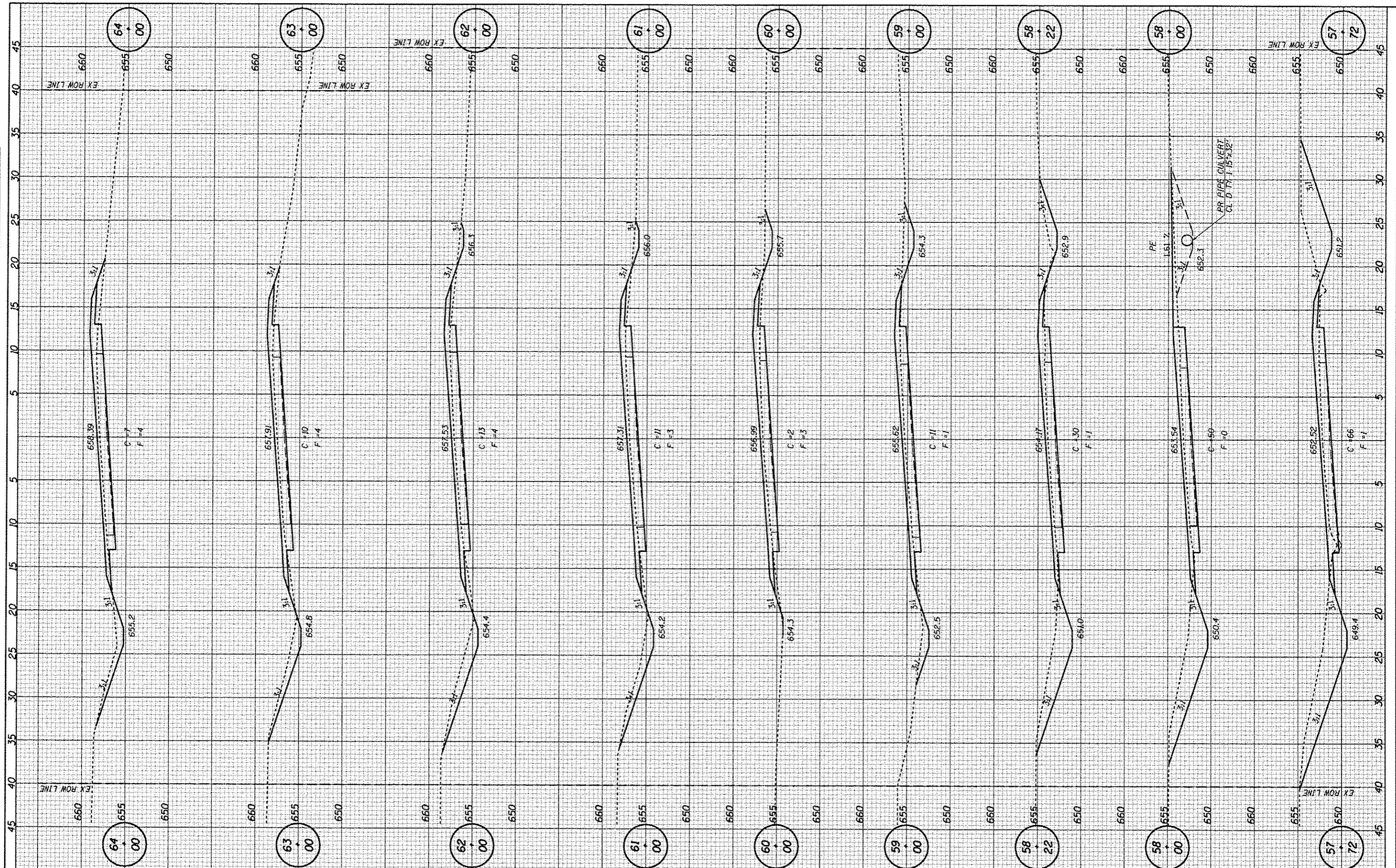

CEC Cummins Engineering Corporation
Civil and Structural Engineering

JOB # 2184
FILE NAME = 2184xcep.dgn
PLOT SCALE = 10,0000 x f / 1in.
PLOT DATE = 11/21/2013

DESIGNED - NAK
DRAWN - TJD
CHECKED - NAK
DATE - 10/15/2010

REVISED -
REVISED -
REVISED -
REVISED -

**MACOUPIN COUNTY
CH 12 IMPROVEMENTS**

CROSS SECTIONS

SCALE: SHEET NO. OF SHEETS STA. TO STA.

F.A.S. RTE. 732	SECTION 01-00079-00-FP	COUNTY MACOUPIN	TOTAL SHEETS 141	SHEET NO. 95
FED. ROAD DIST. NO.		ILLINOIS FED. AID PROJECT		
		CONTRACT NO. 93574		

FINAL SURVEY	BY	DATE
SURVEYED		
NOTED		
AREAS CHECKED		

ORIGINAL SURVEY	BY	DATE
SURVEYED		
NOTED		
AREAS CHECKED		

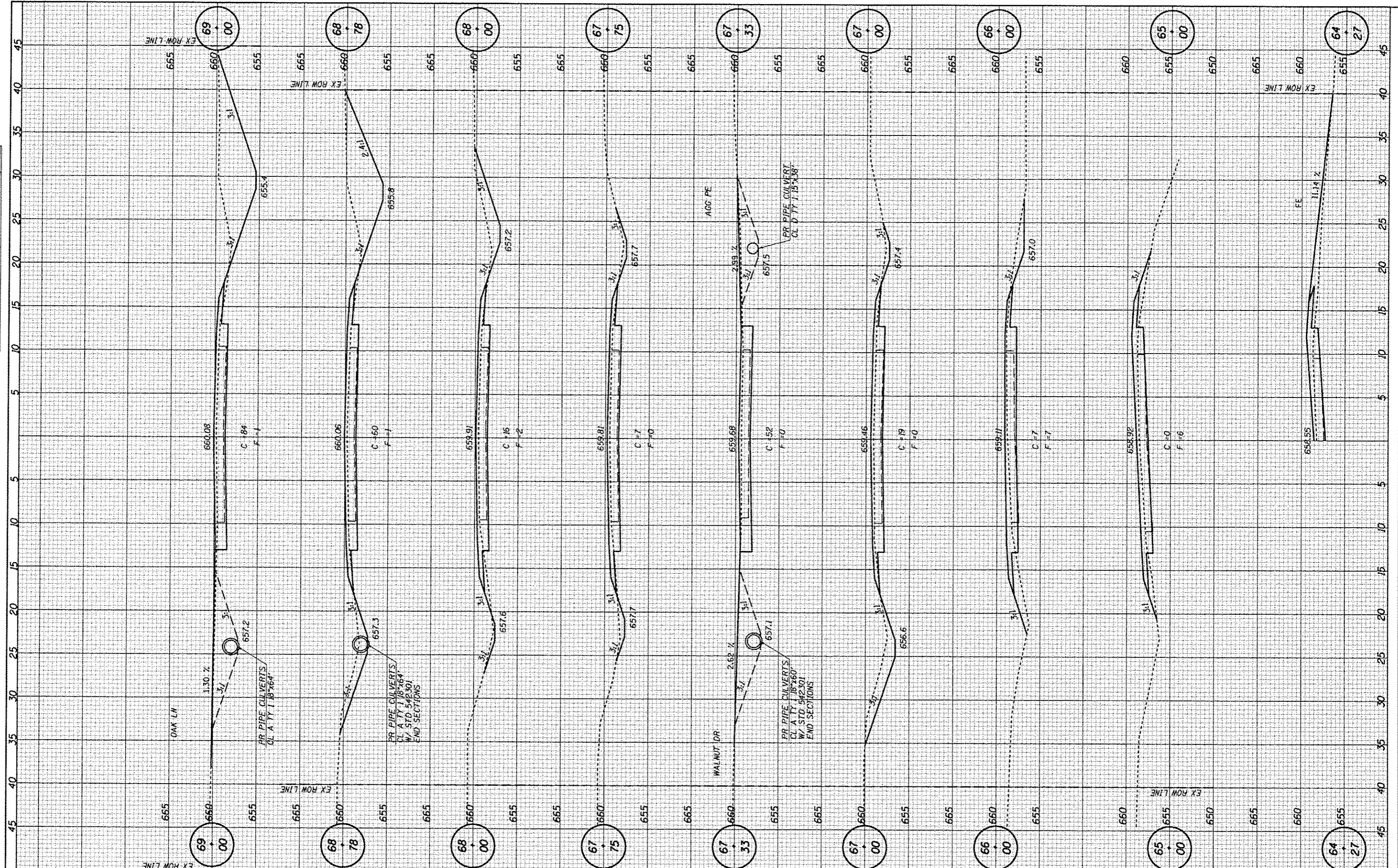

CEC Cummins
Engineering
Corporation
Civil and Structural Engineering

JOB # 2184
FILE NAME = 2184*acc.dgn
PLOT SCALE = 1/8"=1'-0"
PLOT DATE = 11/21/2013

DESIGNED - NAK
DRAWN - TJD
CHECKED - NAK
DATE - 10/15/2010

REVISED -
REVISED -
REVISED -
REVISED -

**MACOUPIN COUNTY
CH 12 IMPROVEMENTS**

CROSS SECTIONS

SCALE: SHEET NO. OF SHEETS STA. TO STA.

F.A.S. RTE.	SECTION	COUNTY	TOTAL SHEETS	SHEET NO.
732	01-00079-00-FP	MACOUPIN	141	96
FED. ROAD DIST. NO.	ILLINOIS FED. AID PROJECT	CONTRACT NO. 93574		

FINAL SURVEY	DATE
SURVEYED	BY
PLOTTED	
TEMPLATE	
NOTE BOOK	
AREA	
AREAS CHECKED	

ORIGINAL SURVEY	DATE
SURVEYED	BY
PLOTTED	
TEMPLATE	
NOTE BOOK	
AREA	
AREAS CHECKED	

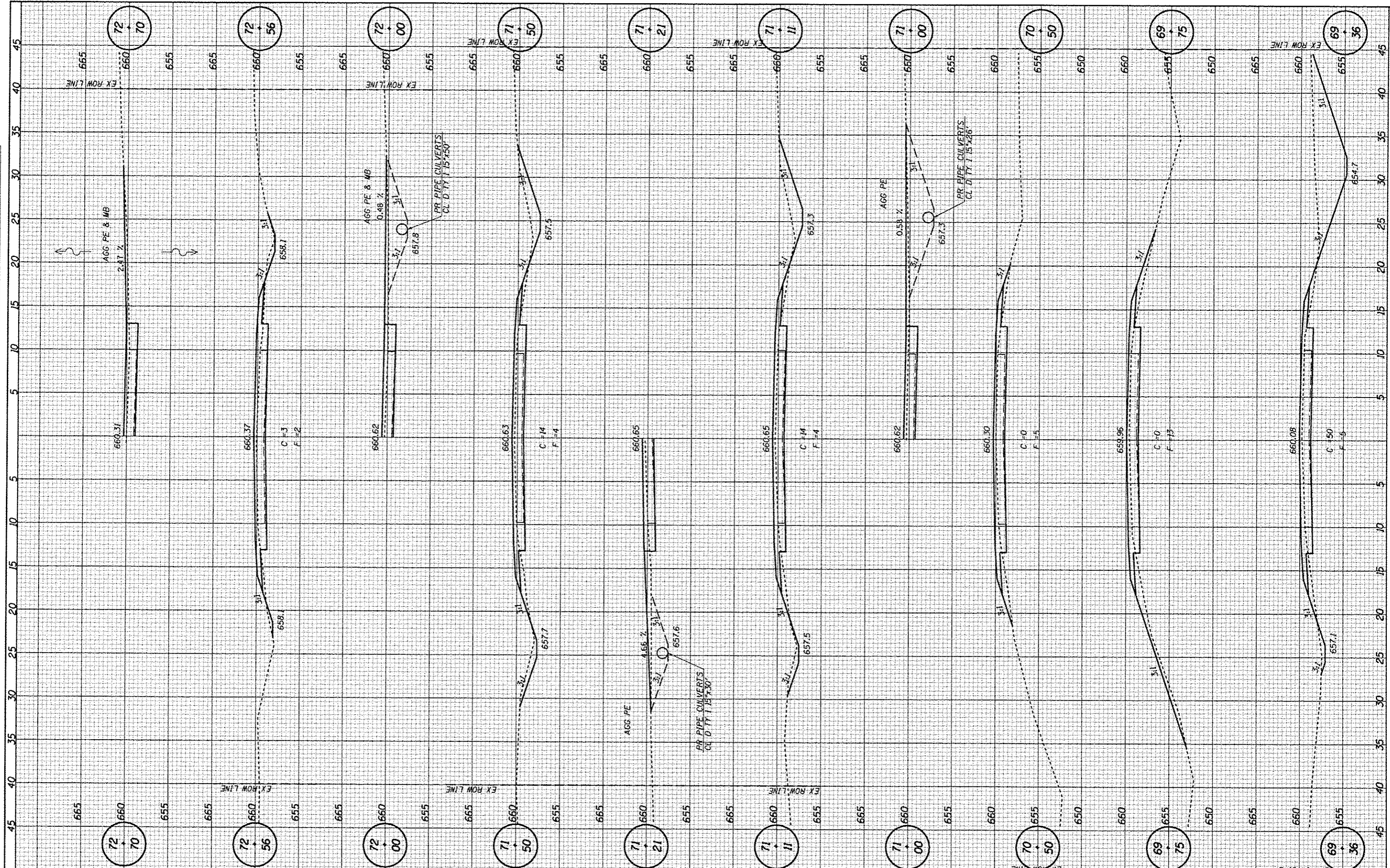

CEC Cummins Engineering Corporation
Civil and Structural Engineering

JOB # 2184
FILE NAME = 2184xsec.dgn
PLOT SCALE = 10,0000 s/f / IN.
PLOT DATE = 11/21/2013

DESIGNED - NAK
DRAWN - TJD
CHECKED - NAK
DATE - 10/15/2010

REVISED -
REVISED -
REVISED -
REVISED -

**MACOUPIN COUNTY
CH 12 IMPROVEMENTS**

CROSS SECTIONS

SCALE: SHEET NO. OF SHEETS STA. TO STA.

F.A.S. RTE.	SECTION	COUNTY	TOTAL SHEETS	SHEET NO.
732	01-00079-00-FP	MACOUPIN	141	97
CONTRACT NO. 93574				
FED. ROAD DIST. NO. ILLINOIS FED. AID PROJECT				

FINISHED	BY	DATE
SURVEYED		
PLOTTED		
NOTE BOOK		
AREAS CHECKED		
NO.		

ORIGINAL	BY	DATE
SURVEYED		
PLOTTED		
NOTE BOOK		
AREAS CHECKED		
NO.		

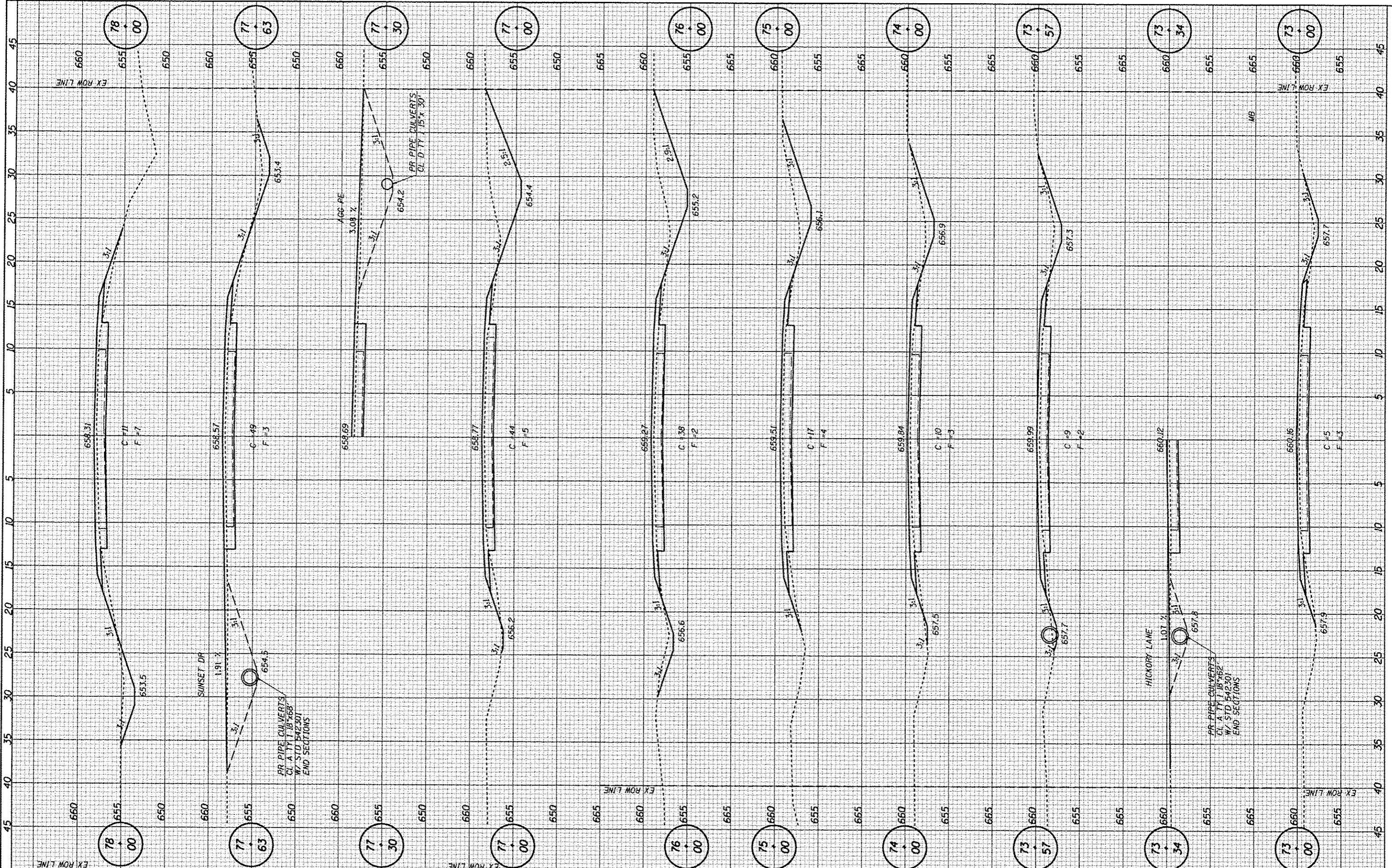

CEC Cummins Engineering Corporation
Civil and Structural Engineering

JOB # 2184
FILE NAME = 2184.mxd.dgn
PLOT SCALE = 1/8" = 1' / IN.
PLOT DATE = 11/21/2013

DESIGNED - NAK
DRAWN - TJD
CHECKED - NAK
DATE - 10/15/2010

REVISED -
REVISED -
REVISED -
REVISED -

**MACOUPIN COUNTY
CH 12 IMPROVEMENTS**

CROSS SECTIONS
SCALE: SHEET NO. OF SHEETS STA. TO STA.

F.A.S. RTE.	SECTION	COUNTY	TOTAL SHEETS	SHEET NO.
732	01-00079-00-FP	MACOUPIN	141	98
FED. ROAD DIST. NO.		ILLINOIS FED. AID PROJECT		CONTRACT NO. 93574

FINAL SURVEY	SURVEYED	BY	DATE
NOTE BOOK	PLOTTED		
NO.	TEMPLATE		
	AREAS CHECKED		

ORIGINAL SURVEY	SURVEYED	BY	DATE
NOTE BOOK	PLOTTED		
NO.	TEMPLATE		
	AREAS CHECKED		

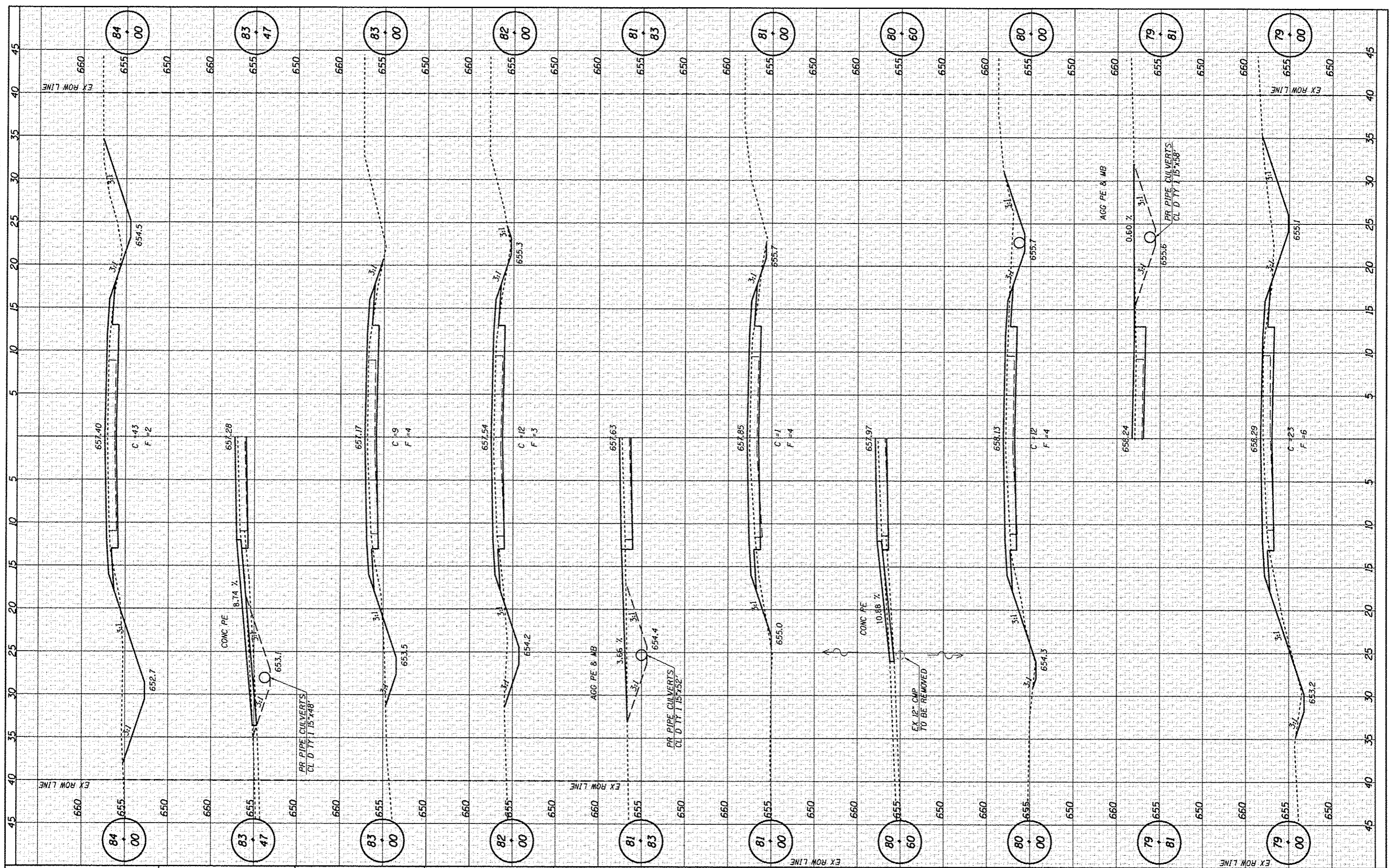

CEC Cummins Engineering Corporation
Civil and Structural Engineering

JOB # 2184
FILE NAME = 2184xaso.dgn
PLOT SCALE = 1/8" = 1' / IN.
PLOT DATE = 12/5/2013

DESIGNED - NAK
DRAWN - TJD
CHECKED - NAK
DATE - 10/15/2010

REVISED -
REVISED -
REVISED -
REVISED -

**MACOUPIN COUNTY
CH 12 IMPROVEMENTS**

CROSS SECTIONS

SCALE: SHEET NO. OF SHEETS STA. TO STA.

F.A.S. RTE.	SECTION	COUNTY	TOTAL SHEETS	SHEET NO.
732	01-00079-00-FP	MACOUPIN	141	99
FED. ROAD DIST. NO. [ILLINOIS] FED. AID PROJECT			CONTRACT NO. 93574	

ORIGINAL SURVEY	BY	DATE
SURVEYED		
PLOTTED		
TEMPLATE		
NOTE BOOK		
AREAS CHECKED		
NO.		

FINAL SURVEY	BY	DATE
SURVEYED		
PLOTTED		
TEMPLATE		
NOTE BOOK		
AREAS CHECKED		
NO.		

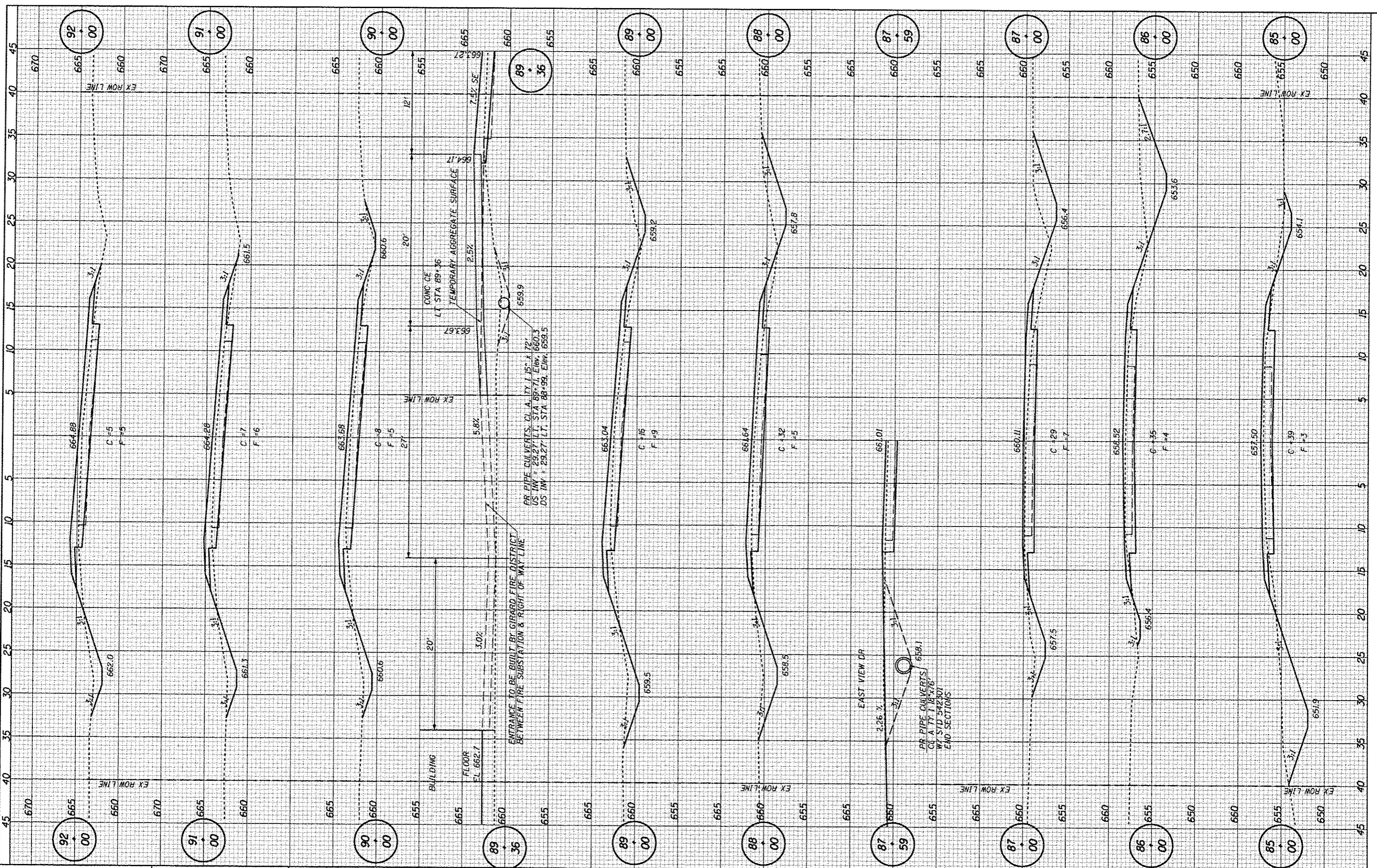

CEC Cummins Engineering Corporation
Civil and Structural Engineering

JOB # 2184
FILE NAME = 2104xxx.dgn
PLOT SCALE = 10,0000 x f / IN.
PLOT DATE = 11/21/2013

DESIGNED - NAK
DRAWN - TJD
CHECKED - NAK
DATE - 10/15/2010

REVISED -
REVISED -
REVISED -
REVISED -

**MACOUPIN COUNTY
CH 12 IMPROVEMENTS**

CROSS SECTIONS

SCALE: SHEET NO. OF SHEETS STA. TO STA.

F.A.S. RTE.	SECTION	COUNTY	TOTAL SHEETS	SHEET NO.
732	01-00079-00-FP	MACOUPIN	141	100
FED. ROAD DIST. NO.		ILLINOIS FED. AID PROJECT		CONTRACT NO. 93574