

\*Cut off drain 6" below the deck

**PLUG DRAIN DETAIL**

(See sheet 1 of 12 for locations)

(16 Req'd)

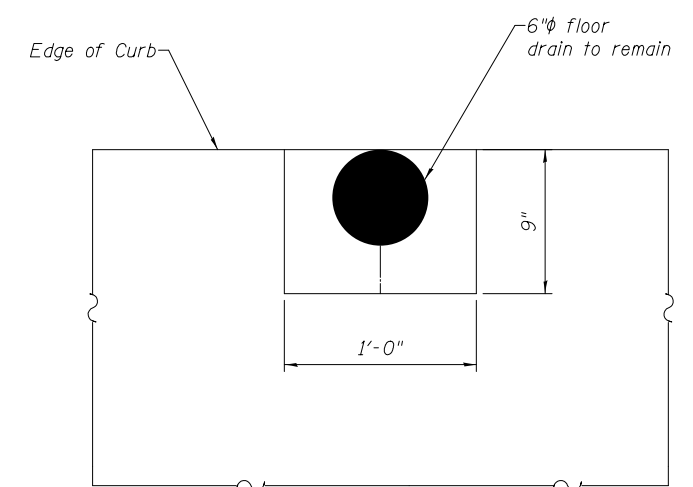

**DRAIN DETAIL**

Slope to drain with 1" minimum HMA at drains

(See sheet 1 of 12 for locations to Remain)  
(20 Req'd)

DESIGNED - AYV	EXAMINED _____	DATE - _____
CHECKED - _____	ENGINEER OF STRUCTURAL SERVICES	REVISOR _____
DRAWN - AYV	PASSED _____	REVISOR _____
CHECKED - _____	ENGINEER OF BRIDGES AND STRUCTURES	REVISOR _____

**STATE OF ILLINOIS  
DEPARTMENT OF TRANSPORTATION**

**DRAIN DETAILS  
SN 042-0012**

SHEET NO. 7 OF 12 SHEETS

F.A.P. RTE.	SECTION	COUNTY	TOTAL SHEETS	SHEET NO.
304	4-BY, 4B-1	JERSEY	26	21
ILLINOIS FED. AID PROJECT			CONTRACT NO. 76G49	