

TRANSITION DETAIL
SECTION A-A

HOT-MIX ASPHALT SURFACE REMOVAL-BUTT JOINT

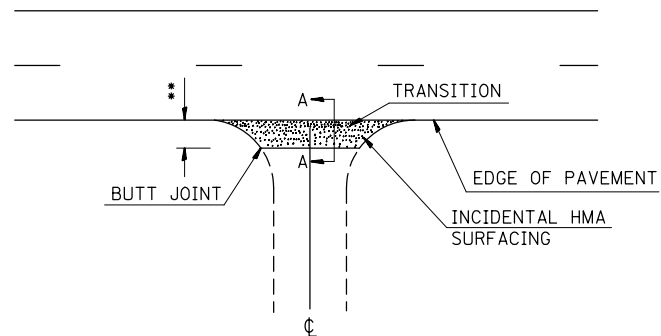

SIDEROAD DETAIL

EOP ELEVATION CHANGE	**TOTAL TRANSITION LENGTH
3/4"	3.5'
1"	5'
1-1/2"	7.5'
2"	10'
2-1/2"	12.5'
3"	15'
3-1/2"	17.5'
4"	20'
4-1/2"	22.5'
5"	25'
5-1/2"	27.5'
6"	30'

NOTE:
WHERE THE HMA TRANSITION IS MATCHING INTO AN EXISTING HMA SIDE ROAD SURFACE, A MILLED BUTT JOINT SHALL BE CONSTRUCTED WITHIN THE LIMITS OF THE TOTAL TRANSITION LENGTH ON THE LOCAL ROUTE.

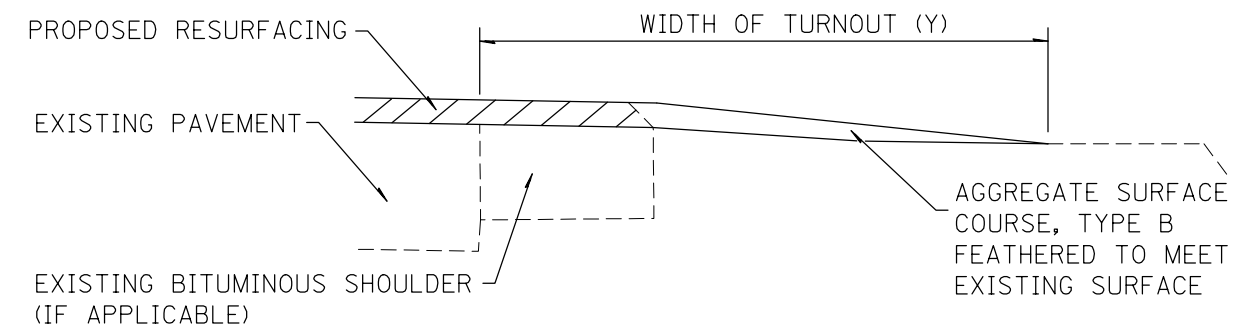

TYPICAL SECTION AT MAILBOX TURNOUT
NOTE: SEE STANDARD 406201 FOR MAILBOX TURNOUT DETAILS

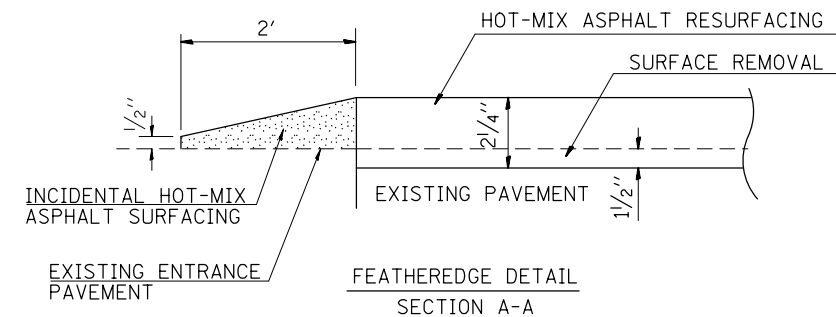

FEATHEREDGE DETAIL
SECTION A-A

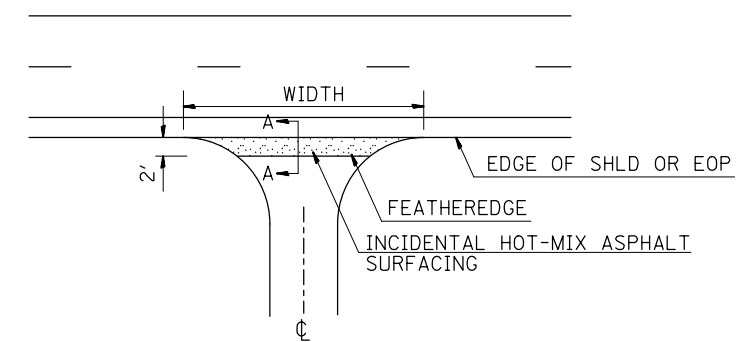

ENTRANCE DETAIL

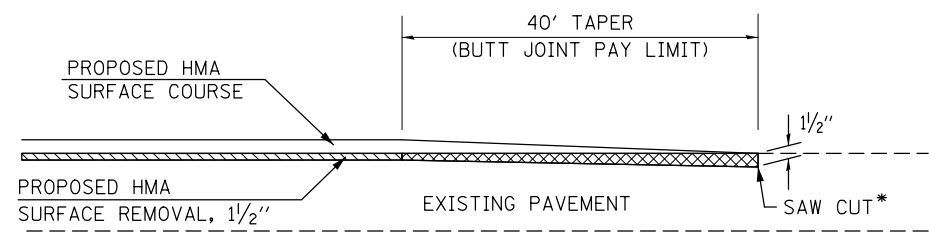

* COST OF SAWCUT TO BE INCLUDED IN HOT-MIX ASPHALT SURFACE REMOVAL - BUTT JOINT

JOINT ELEVATION VIEW
SEE SCHEDULE FOR LOCATIONS

FILE NAME =	USER NAME = challandeske	DESIGNED -	REVISED -
c:\pwwork\pwwork\challandeske\d0332017\0876025-sht-details.dgn		DRAWN -	REVISED -
	PLOT SCALE = 100.0000' / 1in.	CHECKED -	REVISED -
#MODELNAME#	PLOT DATE = 1/17/2014	DATE -	REVISED -

STATE OF ILLINOIS
DEPARTMENT OF TRANSPORTATION

SCALE: NONE SHEET 1 OF 2 SHEETS STA. TO STA.

DETAILS

F.A.P. RTE.	SECTION	COUNTY	TOTAL SHEETS	SHEET NO.
604	(103,125)RS-2, 125-BR-2	MADISON	46	27
CONTRACT NO. 76G25				
ILLINOIS FED. AID PROJECT				