

METAL SHELL PILE TABLE

Designation and outside diameter	Wall thickness t	Weight per foot (Lbs./ft.)	Inside volume (yd. ³ /ft.)
PP12	0.179"	22.60	0.0274
PP12	0.250"	31.37	0.0267
PP14	0.250"	36.71	0.0368
PP14	0.312"	45.61	0.0361

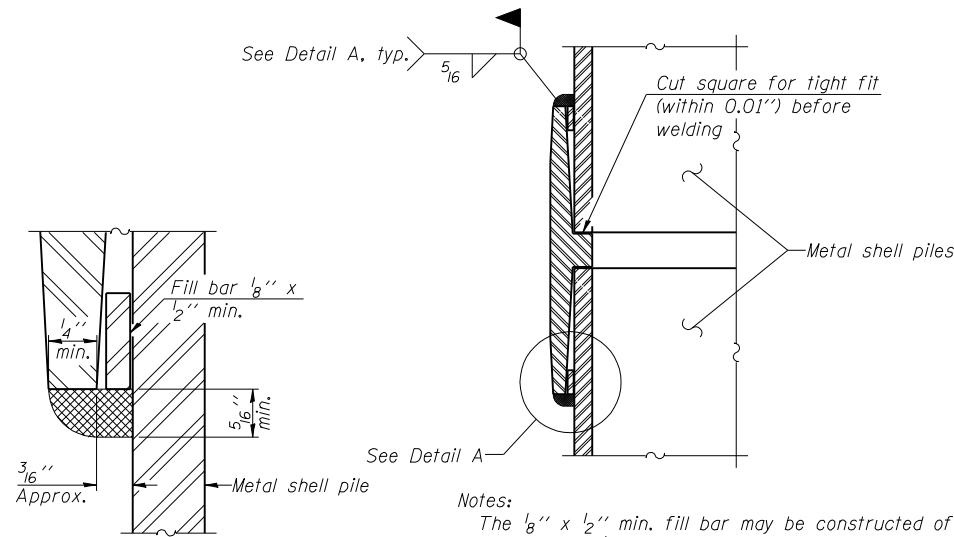

DETAIL A

Notes:
 The 1/8" x 1/2" min. fill bar may be constructed of 2 bars with a 1/8" max. gap between them.
 Pile segments shall be driven to solid contact with splicer before welding.

WELDED COMMERCIAL SPLICE

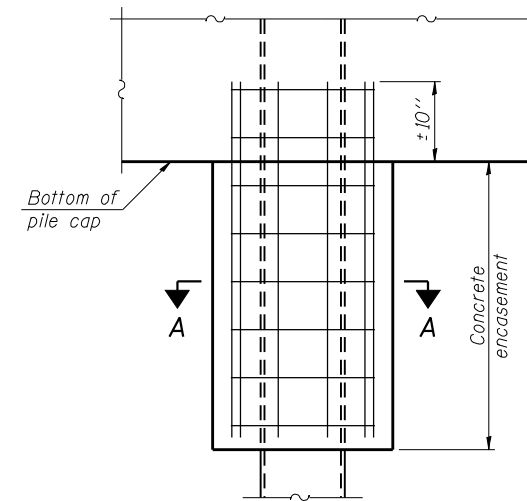

ELEVATION

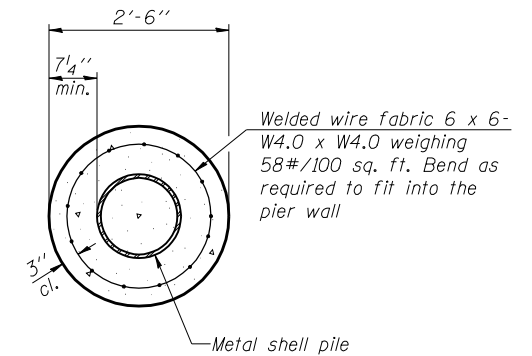

SECTION A-A

Note:
 Forms for encasement may be omitted when soil conditions permit.

CONCRETE ENCASEMENT AT PIERS

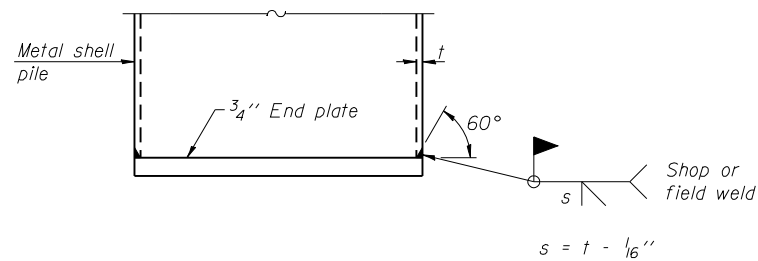

END PLATE ATTACHMENT

$s = t - 1/16"$

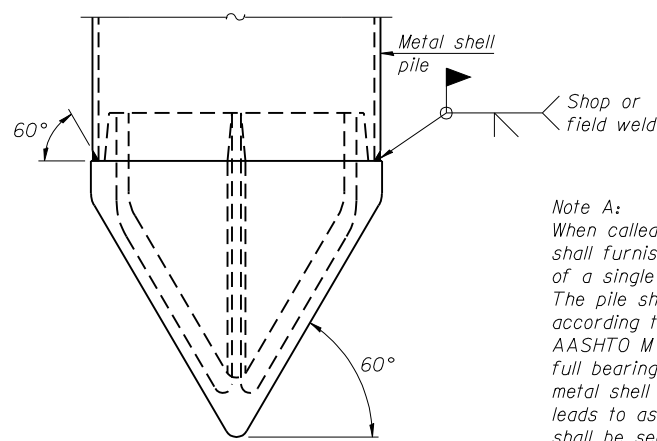

METAL SHELL PILE SHOE ATTACHMENT

(See Note A)

Note A:
 When called for on the plans, the Contractor shall furnish metal shell pile shoes consisting of a single piece conical pile point as shown. The pile shoes shall be cast in one piece steel according to either ASTM A 148 Grade 90-60 or AASHTO M 103 Grade 65-35 and shall provide full bearing over the full circumference of the metal shell pile. The pile shoe shall have tapered leads to assure proper alignment and fitting and shall be secured to the pile with a circumferential weld.

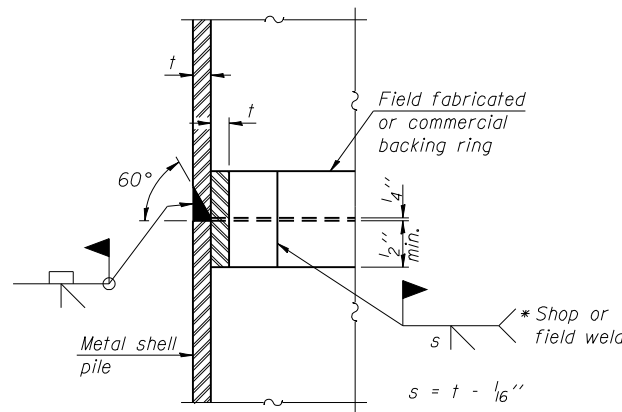

COMPLETE PENETRATION WELD SPLICE

* Field fabricated backing ring may be made from pile shell by removing segment to allow reducing circumference and vertically rejoin with partial joint penetration weld.

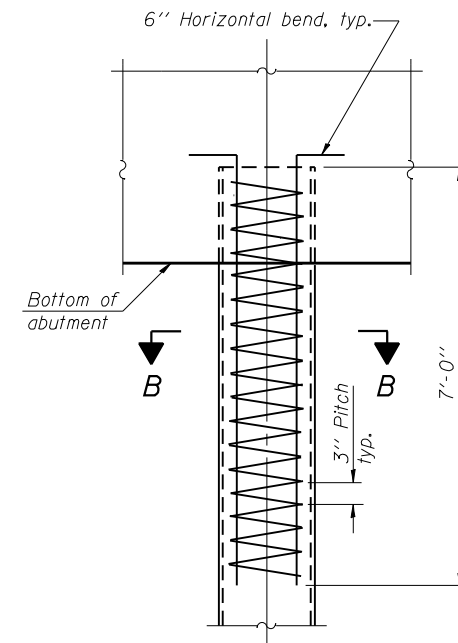

ELEVATION

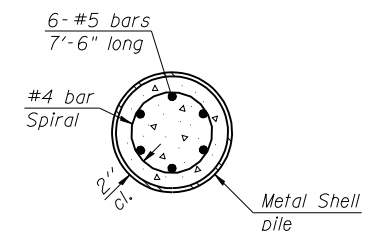

SECTION B-B

METAL SHELL REINFORCEMENT AT ABUTMENTS

Note:
 The metal shell piles shall be according to ASTM A 252 Grade 3.

FILE NAME = 72B82-019-mp11end.dgn
 PROJECT NO. 072B82-8

F-MS
Coombe-Bloxdorf P.C.
 CIVIL ENGINEERS-
 STRUCTURAL ENGINEERS-
 LAND SURVEYORS
 Design Firm License No. 184-002703

1-27-12

USER NAME = .MML.	DESIGNED - AMC	REVISED -
PLOT SCALE = 0.1667' / IN.	CHECKED - MCB	REVISED -
PLOT DATE = 10/23/2013	DRAWN - MML	REVISED -
	CHECKED - MCB	REVISED -

STATE OF ILLINOIS
DEPARTMENT OF TRANSPORTATION

METAL SHELL PILE DETAILS
STRUCTURE NO. 054-0515

SHEET NO. 19 OF 23 SHEETS

F.A.P. RTE.	SECTION	COUNTY	TOTAL SHEETS	SHEET NO.
717	102B-1, 102CR, 102BR-2IRS-5	LOGAN	218	73
CONTRACT NO. 72B82				
ILLINOIS FED. AID PROJECT				