



# Illinois Department of Transportation

2300 South Dirksen Parkway / Springfield, Illinois / 62764

February 20, 2014

SUBJECT: TR 428 (Richton Road)  
Section 11-02118-01-BR  
Will County  
Contract No. 61A02  
Item 058  
February 28, 2014 Letting  
Addendum (A)

## NOTICE TO PROSPECTIVE BIDDERS:

Due to clarify information necessary to revise the following:

### **1. Revised pages 28 & 29 of the Special Provisions.**

Prime contractors must utilize the enclosed material when preparing their bid and must include any Schedule of Prices changes in their bidding proposal.

Bidders using computer-generated bids are cautioned to reflect any and all Schedule of Prices changes, if involved, into their computer programs.

Very truly yours,

John Baranzelli, P.E.  
Acting Engineer of Design and Environment

A handwritten signature in cursive script, reading "Ted B. Walschleger P.E.".

By: Ted B. Walschleger, P.E.  
Engineer of Project Management

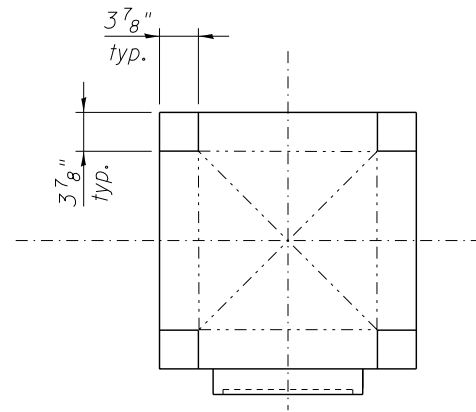

SECTION B-B

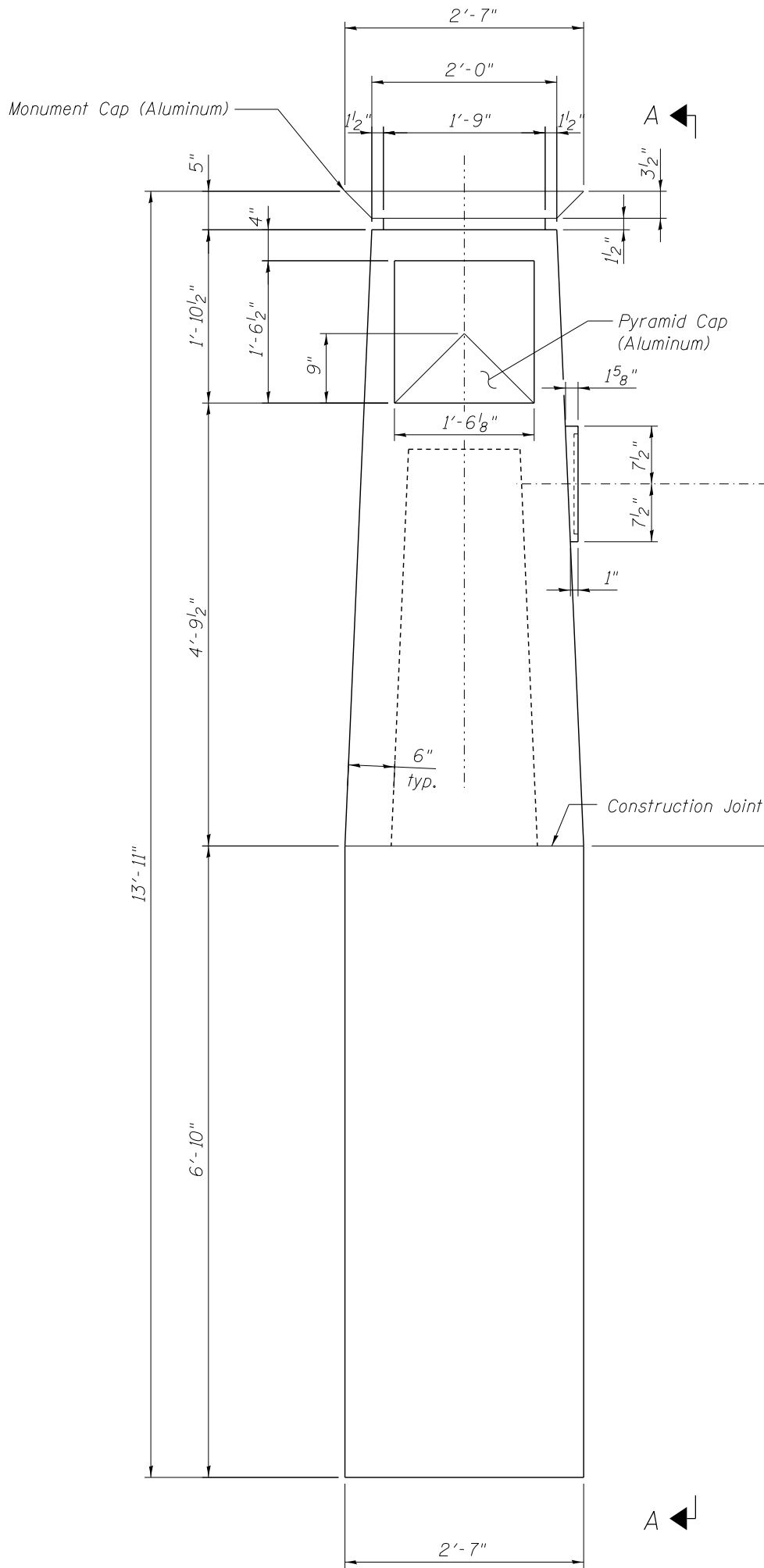

MONUMENT ELEVATION

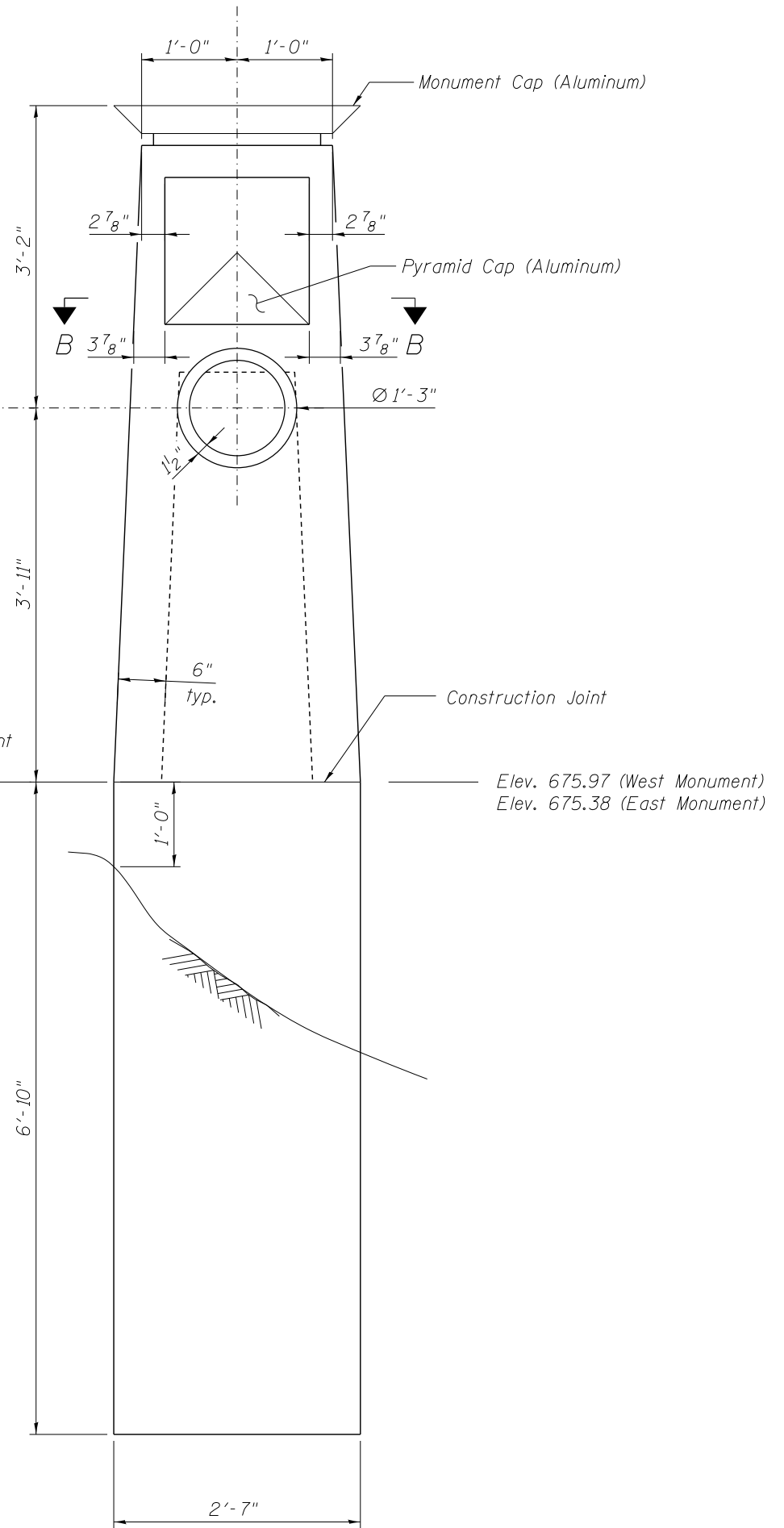

VIEW A-A

