

STANDARD DRAINAGE STRUCTURES FOR PRIVATE DEVELOPMENT

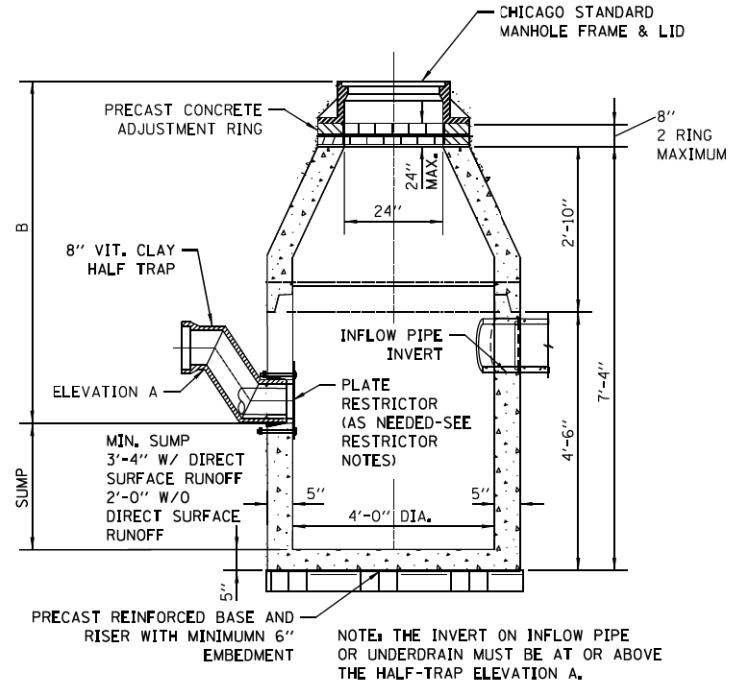

**PLATE RESTRICTOR CATCH BASIN
CONICAL SECTION
N.T.S.**

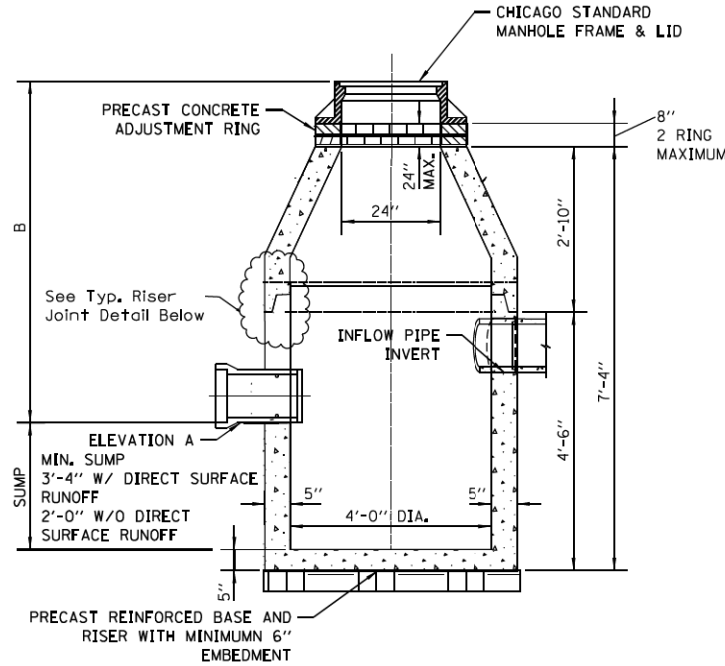

**STANDARD CATCH BASIN
CONICAL SECTION
N.T.S.**

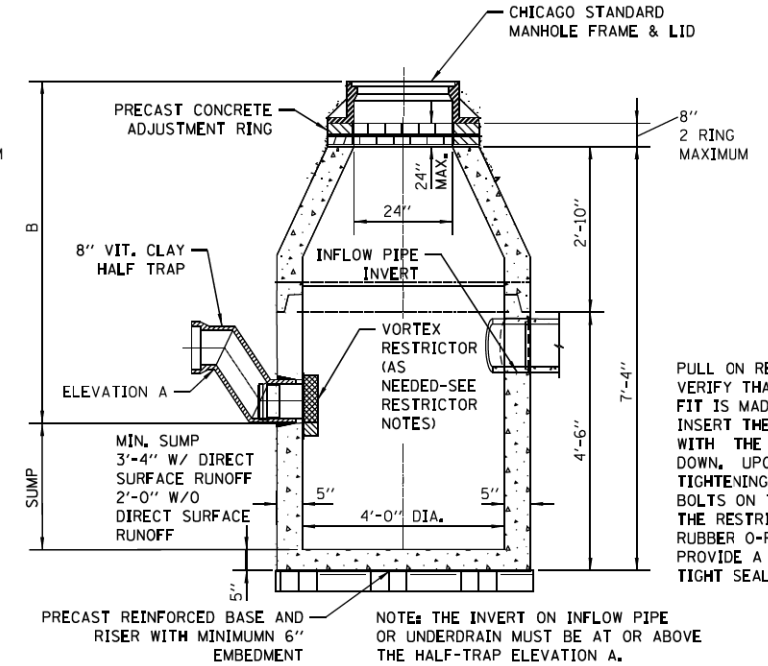

**VORTEX RESTRICTOR CATCH BASIN
CONICAL SECTION
N.T.S.**

PULL ON RESTRICTOR TO VERIFY THAT A TIGHT FIT IS MADE. INSERT THE RESTRICTOR WITH THE OPENING DOWN, UPON TIGHTENING OF THE 2 BOLTS ON THE FACE OF THE RESTRICTOR, THE RUBBER O-RINGS WILL PROVIDE A WATER-TIGHT SEAL.

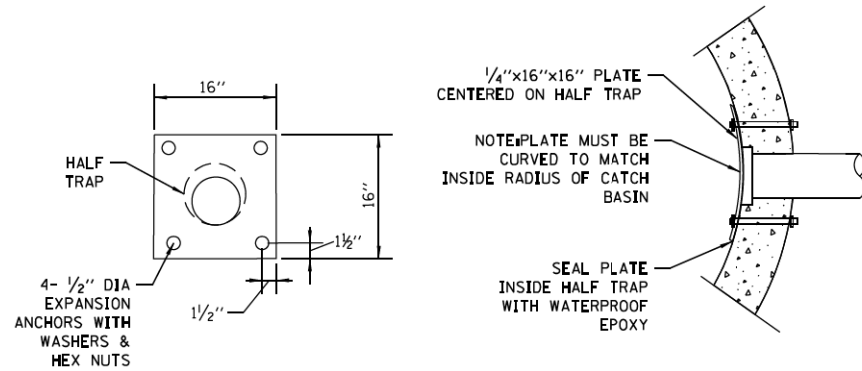

NOTES:

1. THE RESTRICTOR MUST BE INSTALLED IN CATCH BASINS OR MANHOLES WITH 2' MIN. SUMPS.
2. PLATE AND FASTENERS MUST BE FABRICATED IN STAINLESS STEEL, DUCTILE IRON, OR EQUIVALENT WATERPROOF/WEATHER PROOF MATERIALS.
3. MIN. ORIFICE SIZE= 2.5" DIA.
4. IF B < 4 FEET, THEN USE A FLAT TOP SLAB CATCH BASIN AS NECESSARY.

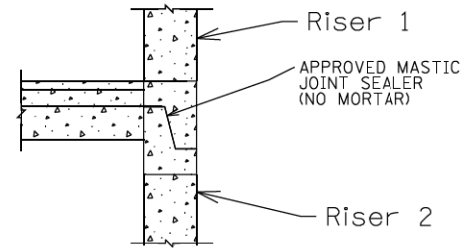

Riser Joint Detail (Typ.)

GENERAL NOTES:

1. CATCH BASIN TO CATCH BASIN CONNECTIONS ARE ALLOWED IN PRIVATE SITES & ALLEYS. ONLY THE DOWNSTREAM CATCH BASIN IS REQUIRED TO HAVE A HALF-TRAP.
2. IF B < 4 FEET, THEN USE A FLAT TOP SLAB CATCH BASIN AS NECESSARY.
3. INLETS AND 3' DIAMETER CATCH BASINS ARE TO BE USED ONLY WITH PRIOR APPROVAL OF THE DEPT OF WATER MANAGEMENT- ENGINEERING SERVICES, SEWER SECTION, AND THE DEPT. OF BUILDINGS STORMWATER REVIEWER.

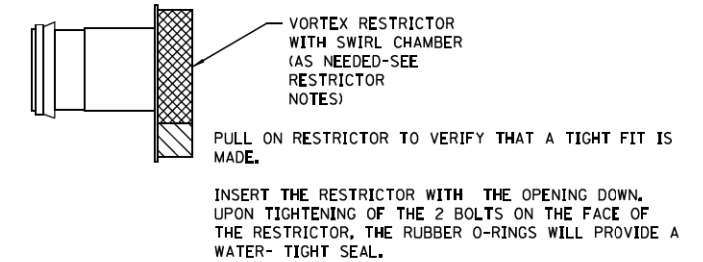

NOTES:

1. IF B < 4 FEET, THEN USE A FLAT TOP SLAB CATCH BASIN AS NECESSARY.
2. THE RESTRICTORS CAN BE OBTAINED FROM DWM CENTRAL DISTRICT AT 3901 S. ASHLAND AVE. THE CONTRACTOR SHOULD ARRANGE FOR PICK UP BY CONTACTING 312-747-1177 (7AM TO 3PM, M-F)

STANDARD REVISIONS		PERCENT COMPLETE	DATE	CITY OF CHICAGO DEPARTMENT OF WATER MANAGEMENT BUREAU OF ENGINEERING SERVICES	DRAWN DESIGNED CHECKED	SUB CHECKED
DATE	DESCRIPTION					
12/09/10	APPROVED PLAN	30		DRAINAGE STRUCTURE DETAILS PRIVATE DEVELOPMENT	A.13	PN
		60				
		75				
		90				
		100				
		BULLETIN				

G:\BCH\2013\17\CDOT\Standards\2013-08-07 CDWM Standards from AECOM Anna\CDWM_Details.cel
 12/18/2013
 FILE PATH = p:\388935-p\m\l\aecon\m\l\local\p\aecon\m\l\documents\01_Americas\Transportation\66269938_Circle\Phase_1\1\000_CDD\006_Roadway_Sheets\66269938_Sht-CDWM-05A.dgn

D160W29-Sht-CDWM-05A.dgn	DESIGNED - CDWM	REVISED - 12/18/2013
USER NAME = BAW1tor1	DRAWN - CDWM	REVISED -
PLOT SCALE = 2.0000' / in.	CHECKED - CDWM	REVISED -
PLOT DATE = 12/19/2013	DATE - 10/30/2013	REVISED -

**STATE OF ILLINOIS
DEPARTMENT OF TRANSPORTATION**

**CITY OF CHICAGO - DEPARTMENT OF WATER MANAGEMENT
STANDARD DETAILS A.13**

SCALE: NONE SHEET 5A OF 6 SHEETS STA. TO STA.

F.A.I. R.T.E.	SECTION	COUNTY	TOTAL SHEETS	SHEET NO.
90/94/290	2013-011R	COOK	356	345A
CONTRACT NO. 60W29			ILLINOIS FED. AID PROJECT	